



## ENDÜSTRİYEL TRANSFER POMPALARI INDUSTRIAL TRANSFER PUMPS

**İÇ DİŞLİ POMPALAR  
INTERNAL GEAR PUMPS**



**HELİS DİŞLİ POMPALAR  
HELICAL GEAR PUMPS**



**LOBLU POMPALAR  
LOBE PUMPS**



**PASLANMAZ ve BRONZ POMPALAR  
STAINLESS STEEL & BRONZE PUMPS**



<https://btstech.pl>  
+48 22 390 63 48  
sklep@btstech.pl



KULLANIM AMACI		DESCRIPTION	
KUPAR DİŞLİ TRANSFER POMPALARI viskozitesi yüksek yani akışkanlığı suya göre nispeten az olan sıvıların bir yerden başka bir yere transfer edilmesinde kullanılır. Transfer edilecek malzemelerin kimyasal olarak yağlayıcı özelliği olması yâda fi ziksel olarak sürtünmeyi azaltacak film oluşturma özelliği olması gerekir.		KUPAR GEAR PUMPS are used to transfer liquids, which is more viscous than water, from place to place. These fl uids should be chemically lubricating and should create a fi lm between friction surfaces to minimize the wear	
KULLANIM ALANI		APPLICATION	
Çikolata	Sabun	Chocolate	Soap
Fuel Oil	Reçel	Fuel - Oil	Jam
Mazot	Tutkal	Asphalt	Rubber
Deterjan	Boya	Detergent	Pulp and Papper
Melas	Poliol	Industrial Oils	Adhesives
Endüstriyel ve Madeni Yağlar	İzosianat	Automotive Oils	Sealants
Nebati Yağlar	Glikoz	Vegetable Oils	Paints
Diğer viskozitesi yüksük gıda ve petron ürünleri, kimyasal maddeler		Coatings and similar viscous petrol, and chemical products	



Kupar dişli transfer pompalarının tip ve büyüklük seçiminde göz önünde bulundurulması gereken kıstaslar genel olarak aşağıda belirtilmiştir. Daha detaylı bilgi ve pompa seçiminizin doğruluğunu teyid için fi rmamızla irtibat kurmanız yararlı olacaktır

Pompa seçiminde en önemli kıstaslardan biri viskozitedir. Malzemenin viskozitesi hem pompa tipinin seçiminde, hem devir seçiminde hem de pompanın üretim ve montaj toleransları, çalışma boşlukları belirlenmesi için en önemli değişkendir. **KUPAR DİŞLİ TRANSFER POMPALARI** için Pompa seçiminde dikkat edilmesi gereken 4 önemli husus vardır.

**Pompa Tipi:** Genel prensip viskozitesi düşük yani akışkanlığı iyi olan malzemeler için helis dişli pompalar, viskozitesi yüksek yani akışkanlığı düşük malzemeler için içdişli pompalar kullanılmasıdır

**Boru Çapı:** Her boru çapından, yine viskozite göz önünde bulundurularak, transfer edilebilecek maksimum malzeme debisi bellidir. Sistem tasarlanırken bu kıstaslar hesaplanmalı hatta mümkünse tesisat boru çapı belirlenmeden önce pompa seçimi yapılmalıdır. Aksi durumda

o tesisat boru çapından geçebilecek maksimum debi kullanılmak zorundadır.

**Devir:** Yine viskozite ana kıstas olmak üzere akışkanlık azaldıkça devir düşürülmeli, akışkanlık arttıkça yüksek devirler tercih edilmelidir. Dişli pompalarda maksimum 1500 d/d. Pompa devri kullanılır. 1000 d/d. ve 1500 d/d. Dönen pompalar Elektrik motoruna direk akuple edilirken, 500 d/d ve daha düşük devirlerde dönen pompalar elektrik motoruna kayış kasnakla direk veya redüktöre direk monte edilir.

**Pompa Çalışma Boşlukları:** Pompa çalışma boşlukları belirtilen viskozite değerine göre imalat ve montaj sırasında ayarlanır. Pompa çalışma boşlukları hangi malzeme için ayarlandıysa pompa o malzeme için veya yaklaşık aynı viskozite değerlerine sahip akışkanlar için kullanılmalıdır. Aksi durumda pompada sıkışma veya belirtilen debi ve basınç değerlerini sağlamayabilir

When selecting the type and size of the KUPAR GEAR PUMPS there are some criterions, which are generally summarized below. Please contact us for detailed information and selecting criterions.

The most important criterion when selecting gear pumps is the viscosity. Viscosity is important when selecting the type and size, also selecting the pump speed and designing clearances. There are 4 important criterions of pump selection such as:

**Pump Type:** the main principle is to select the helical gear pumps for low viscosities and internal gear pumps for high viscosities.

**Size of the ports:** size of the ports and pipes is again related to the viscosity of the fl uid. Every size of the port and pipe has a capacity of fl ow rate of fl uid according to the viscosity. When selecting pump size and designing the pipe system, the diameter should be calculated accurately or you must be contented with the maximum fl ow rate for that viscosity.

**Pump Speed:** the maximum speed for gear pumps 1500 rpm speed should be reduced according to increasing viscosity. High speeds should be selected for low viscosities, low speeds should be selected for high viscosities. Direct coupling to electric motor is used for 1000 and 1500 rpm. 500 and lower speeds coupling to electric motor with V-belt and direct drive to reduction unit is used.

**Working clearances:** some working clearances are machined during production and some clearances are adjusted during assembly according to the viscosity ranges. Every pump should be used to transfer the fl uid, which has the suitable viscosity, for its working clearances. Otherwise the pump can operate with lower pressure than indicated before or the pump can operate very hard or fully stop.

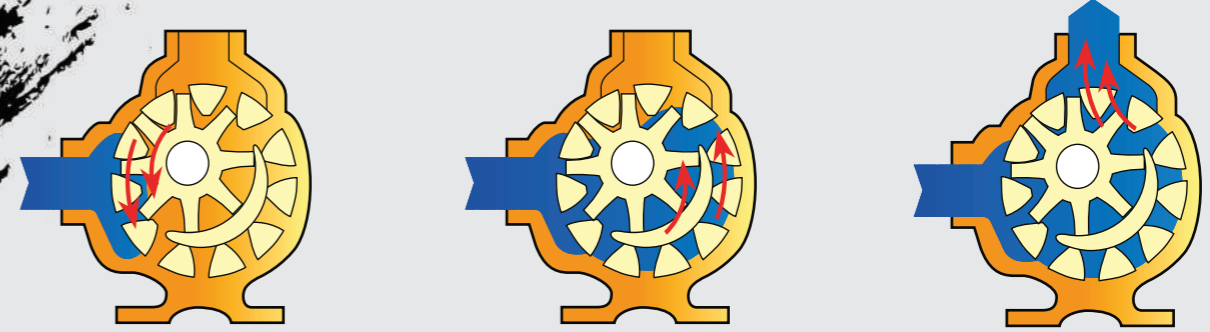

### AVANTAJLARI;

- Aynı akış debi koşullarını sağlayan dış dişli pompalara göre daha küçüktür,
- Yüksek emme kapasitesi, düzenli basma akışı sağlar,
- Düşük devirlerde çalıştığı için yüksek viskoziteli sıvılar için çok idealdir,
- Tek taraflı boşluk ayarı yapılabilir,
- Bakımı kolaydır,
- Uzun ömürlüdür,

### PERFORMANS;

- Sıcaklık aralığı(°C); 20 – 180
- Viskozite aralığı(cp); 28 – 50,000
- Çıkış basınç aralığı(bar); 2 – 14
- Giriş & Çıkış çapları; 3/8", 1/2", 1", 1 1/2", 2", 2 1/2", 3", 4", 6"

### MALZEMELER:

Dış gövde: Pik Dökme Demir,  
Dişliler: Çelik, Sfero Dökme Demir,  
Miller: İmalat Çeliği, Sertleştirilmiş Çelik  
Yataklama: Bronz, Karbon, Rulman  
Sızdırmazlık: Yumuşak Salmastra, Mekanik Salmastra, Özel Tasarım Sızdırmazlık Sistemleri.

### ADVANTAGES;

- Smaller body than the external gear pumps that supplies the same values,
- Positive suction and non pulsating discharge,
- Ideal for high-viscosity liquids because they work at low speeds,
- Adjustable end clearance,
- Easy to maintain,
- Long life,

### PERFORMANCE RANGE;

- Temperature range(°C); 20 – 180
- Viscosity range(cp); 28 – 50,000
- Pressure range(bar); 2 – 14
- Suction & Pressure ports; 3/8", 1/2", 1", 1 1/2", 2", 2 1/2", 3", 4", 6"

### MATERIALS;

Main Body: Cast Iron,  
Gears: Ductile Iron, Steel  
Shafts: Steel, Heat Treated Steel  
Bushing: Bronze, Carbon, Bearing  
Sealing options: Packing, Mechanical Seal, Special Sealing Applications

# İÇ DİŞLİ POMPALAR INTERNAL GEAR PUMPS

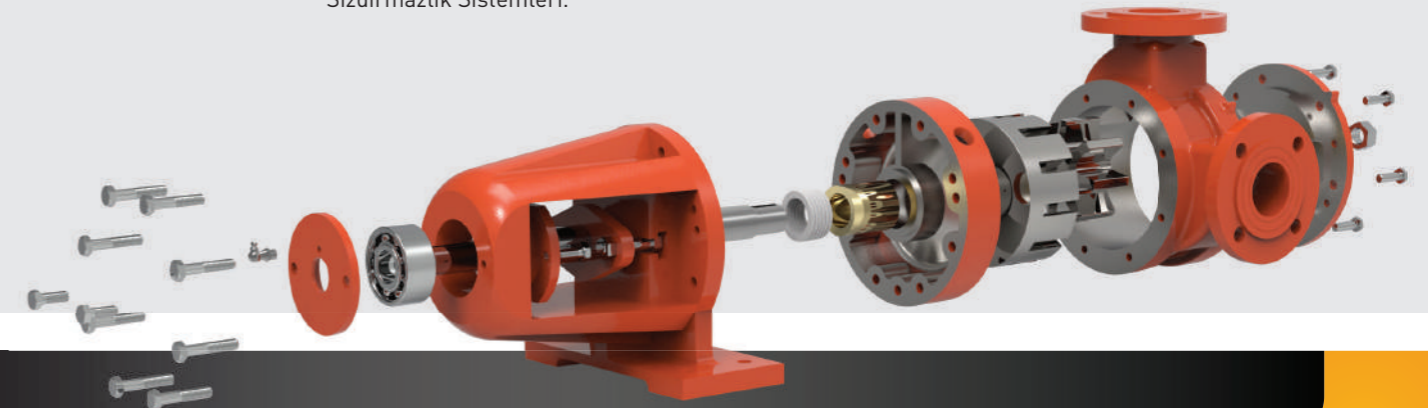

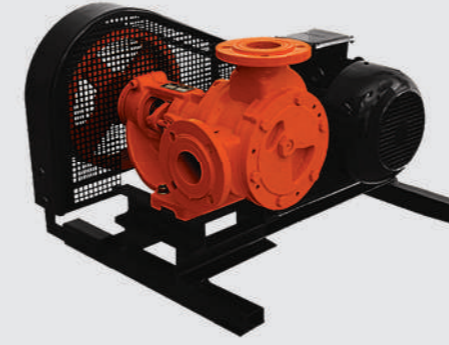

MOTORA KAYIŞ KASNAKLA AKUPLE  
ELECTRIC MOTOR V-BELT DRIVE

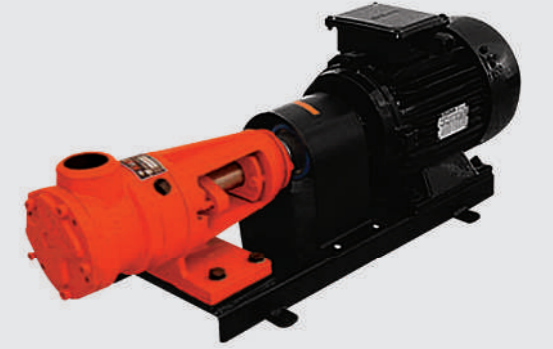

MOTORA DİREK AKUPLE  
ELECTRIC MOTOR DIRECT DRIVE

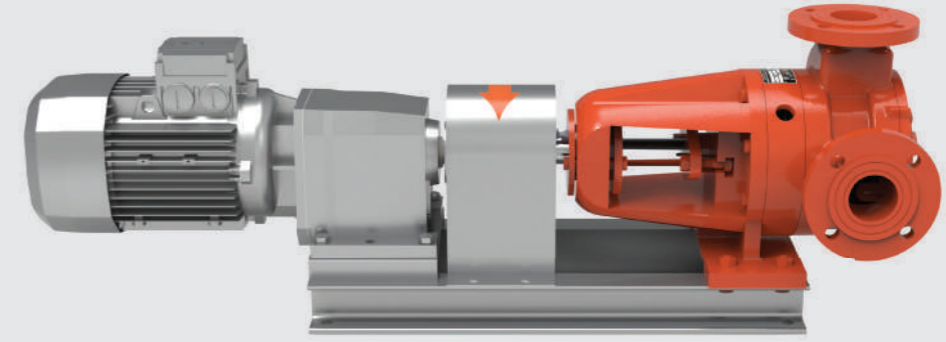

REDÜKTÖRE DİREK AKUPLE  
GEARBOX DIRECT DRIVE

**DONANIMLAR / ACCESSORIES / المعدات**



Tekerlekli Taşıma Ünitesi  
Mobile Unit

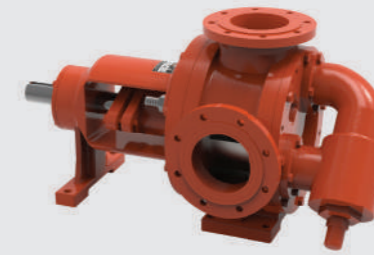

By-Pass  
By-Pass

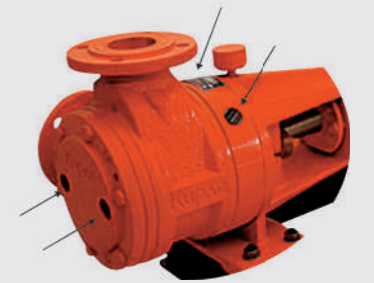

Kapaktan ve Gövdeden Isıtma  
Jacket Both On The Head and Body



Filtre  
Filter



Mekanik Salmastra  
Mechanical Seal

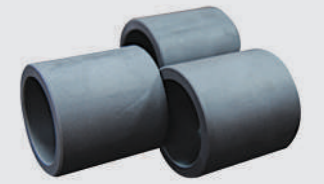

Karbon Yatak  
Carbon Bushing

## KIPK<sup>3/8</sup>"

### ÖZELLİKLER / SPECIFICATIONS

Devir / Speed (rpm)	1.500	1.000	500	100
Debi / Flow (L / h)	175	115	65	12
Basınç / Pressure (max) (bar)	2,5	2,5	5	5
Güç / Power (kW)	0,18	0,18	0,18	0,18
Viskozite / Viscosity (cp)	100	100	1.000	25.000



## KIP<sup>1/2</sup>"

### ÖZELLİKLER / SPECIFICATIONS

Devir / Speed (rpm)	1.500	1.000	500	100
Debi / Flow (L / h)	1.500	1.000	500	100
Basınç / Pressure (max) (bar)	2,5	2,5	2,5	2,5
Güç / Power (kW)	0,75	0,55	0,37	0,25
Viskozite / Viscosity (cp)	100	100	1.000	25.000



## KIP<sup>3/8</sup>"

### ÖZELLİKLER / SPECIFICATIONS

Devir / Speed (rpm)	1.500	1.000	500	100
Debi / Flow (L / h)	350	230	115	25
Basınç / Pressure (max) (bar)	2,5	2,5	2,5	2,5
Güç / Power (kW)	0,25	0,18	0,18	0,18
Viskozite / Viscosity (cp)	100	100	1.000	25.000

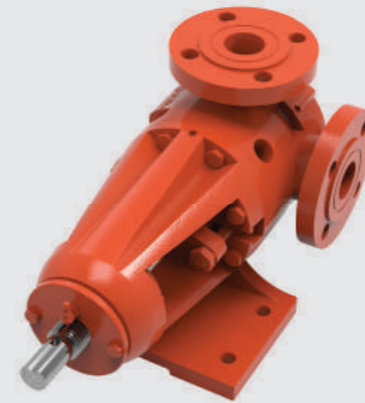

## KIP1"

### ÖZELLİKLER / SPECIFICATIONS

Devir / Speed (rpm)	1.000	500	100	
Debi / Flow (m <sup>3</sup> / h)	2	1	0,2	
Basınç / Pressure (max) (bar)	2,5	2,5	5	2,5
Güç / Power (kW)	1,1	0,75	1,1	0,55
Viskozite / Viscosity (cp)	100	1.000	25.000	

## KIP1"-Y

## KIPK<sup>1/2</sup>"

### ÖZELLİKLER / SPECIFICATIONS

Devir / Speed (rpm)	1.500	1.000	500	100
Debi / Flow (L / h)	900	600	500	60
Basınç / Pressure (max) (bar)	2,5	2,5	2,5	2,5
Güç / Power (kW)	0,55	0,37	0,25	0,18
Viskozite / Viscosity (cp)	100	100	1.000	25.000

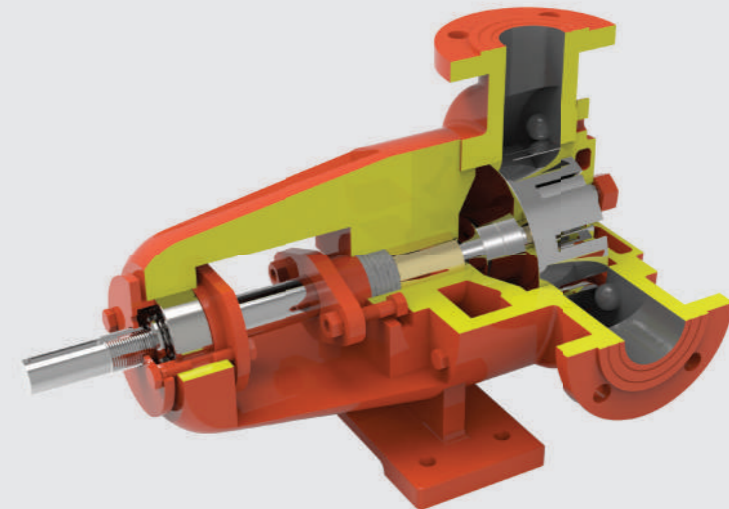

KIPK1½"	KIPK1½"-Y			
ÖZELLİKLER / SPECIFICATIONS				
Devir / Speed (rpm)	1.000	500	100	
Debi / Flow (m3 / h)	4	2	0,4	
Basınç / Pressure (max) (bar)	2,5	2,5	5	2,5
Güç / Power (kW)	1,5	1,1	1,5	0,75
Viskozite / Viscosity (cp)	100	1.000	25.000	

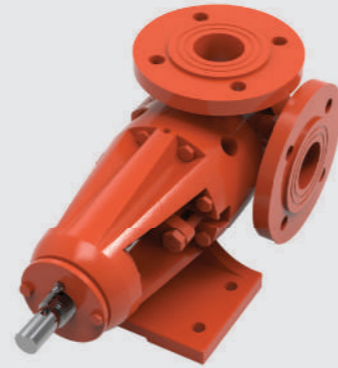

KIP2"	KIP2"-Y			
ÖZELLİKLER / SPECIFICATIONS				
Devir / Speed (rpm)	475	475	100	
Debi / Flow (m3 / h)	14	14	2,5	
Basınç / Pressure (max) (bar)	2,5	5	2,5	5
Güç / Power (kW)	4	5,5	5,5	2,2
Viskozite / Viscosity (cp)	100	1.000	25.000	



KIP1½"	KIP1½"-Y			
ÖZELLİKLER / SPECIFICATIONS				
Devir / Speed (rpm)	475	475	100	
Debi / Flow (m3 / h)	3,5	3,5	0,75	
Basınç / Pressure (max) (bar)	2,5	5	2,5	2,5
Güç / Power (kW)	1,5	2,2	2,2	1,1
Viskozite / Viscosity (cp)	100	1.000	25.000	



KIP2"-Y	KIP2"-Y			
ÖZELLİKLER / SPECIFICATIONS				
Devir / Speed (rpm)	475	475	100	
Debi / Flow (m3 / h)	14	14	2,5	
Basınç / Pressure (max) (bar)	2,5	5	2,5	5
Güç / Power (kW)	4	5,5	5,5	2,2
Viskozite / Viscosity (cp)	100	1.000	25.000	

KIPK2"	KIPK2"-Y			
ÖZELLİKLER / SPECIFICATIONS				
Devir / Speed (rpm)	475	475	100	
Debi / Flow (m3 / h)	7,5	7,5	1,5	
Basınç / Pressure (max) (bar)	2,5	5	2,5	2,5
Güç / Power (kW)	2,2	3	3	1,5
Viskozite / Viscosity (cp)	100	1.000	25.000	

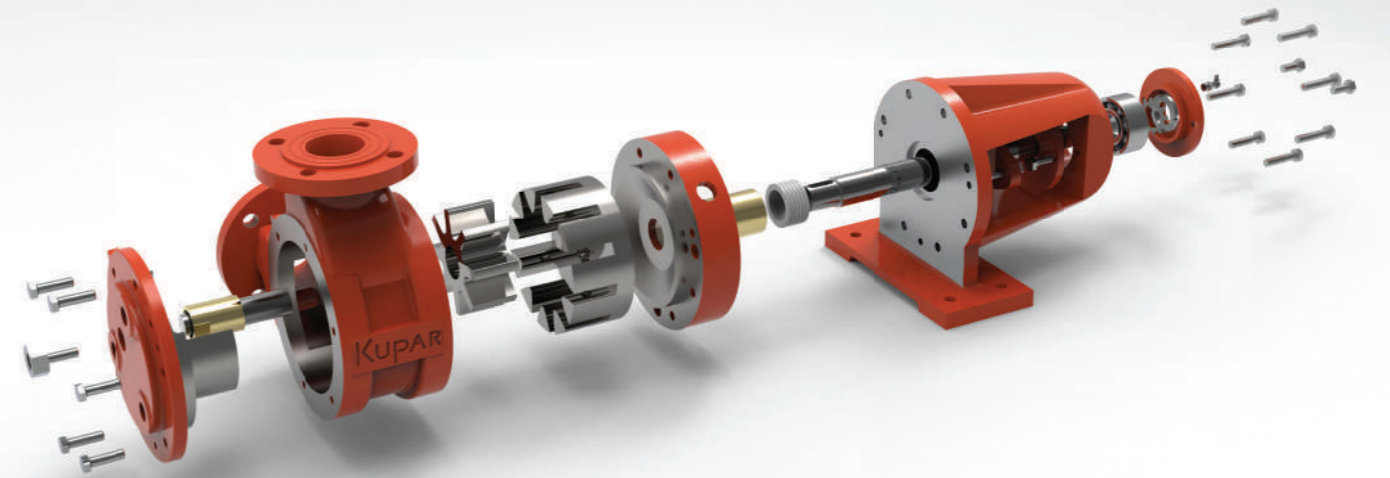

**KIPK2½"**

**ÖZELLİKLER / SPECIFICATIONS**

Devir / Speed (rpm)	475	100		
Debi / Flow (m <sup>3</sup> / h)	25	5		
Basınç / Pressure (max) (bar)	2,5	5	2,5	5
Güç / Power (kW)	5,5	7,5	3	4
Viskozite / Viscosity (cp)	100	25.000		



**KIP4"**

**ÖZELLİKLER / SPECIFICATIONS**

Devir / Speed (rpm)	450	100		
Debi / Flow (m <sup>3</sup> / h)	95	18		
Basınç / Pressure (max) (bar)	2,5	5	2,5	5
Güç / Power (kW)	18,5	22	11	15
Viskozite / Viscosity (cp)	100	25.000		



**KIP2½"**

**ÖZELLİKLER / SPECIFICATIONS**

Devir / Speed (rpm)	450	100		
Debi / Flow (m <sup>3</sup> / h)	35	7		
Basınç / Pressure (max) (bar)	2,5	5	2,5	5
Güç / Power (kW)	7,5	11	4	5,5
Viskozite / Viscosity (cp)	100	25.000		

**KIP6"**

**ÖZELLİKLER / SPECIFICATIONS**

Devir / Speed (rpm)	350	100		
Debi / Flow (m <sup>3</sup> / h)	130	35		
Basınç / Pressure (max) (bar)	2,5	5	2,5	5
Güç / Power (kW)	30	37	18,5	22
Viskozite / Viscosity (cp)	100	25.000		



**KIP3"**

**ÖZELLİKLER / SPECIFICATIONS**

Devir / Speed (rpm)	450	100		
Debi / Flow (m <sup>3</sup> / h)	60	12		
Basınç / Pressure (max) (bar)	2,5	5	2,5	5
Güç / Power (kW)	15	18,5	7,5	11
Viskozite / Viscosity (cp)	100	25.000		

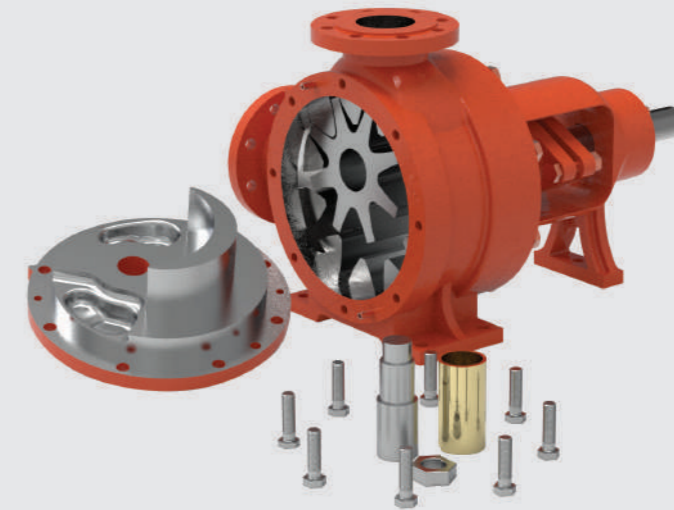

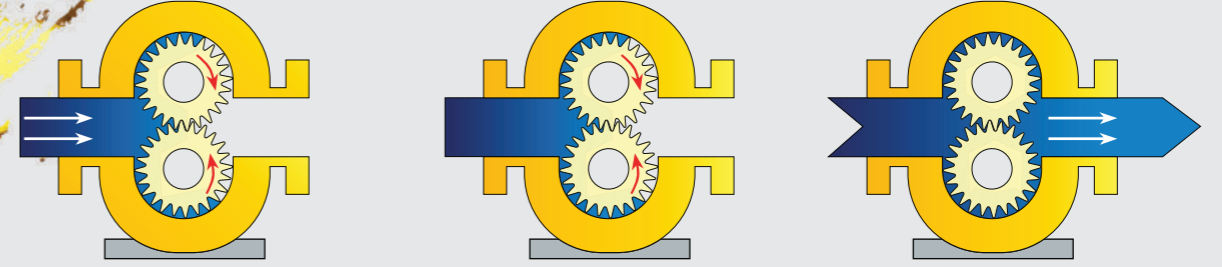

### AVANTAJLARI;

- Yüksek devirlerde çalışabilirler,
- Düşük viskoziteye sahip sıvılar için uygundur,
- Helis dişli olması sebebiyle sessiz çalışırlar,
- Her iki yöne de dönebilirler,
- Bakım ve tamirati kolaydır,

### PERFORMANS;

- Sıcaklık aralığı(Co); 20 – 180
- Viskozite aralığı(cp); 100 – 25000
- Çıkış basınç aralığı(bar); 2 – 14
- Giriş & çıkış çapları; ½", ¾", 1", 1½", 2", 2½", 3", 4", 6"

### MALZEMELER:

Dış gövde: Pik dökme demir

Dişliler: Pik Dökme Demir, Sfero Dökme Demir, İmalat çeliği, Paslanmaz Çelik, Sert Plastikler,

Miller: İmalat çeliği, Sertleştirilmiş Çelik

Yataklama: Bronz, Karbon, Rulman

Sızdırmazlık: Yumuşak Salmastra, Mekanik Salmastra, Özel Tasarım Sızdırmazlık Sistemleri.

### ADVANTAGES;

- High speed,
- Good for relatively low viscosity,
- Relatively quite operation,
- Easy maintenance,
- Operates well in either direction,

### PERFORMANCE;

- Temperature Range(oC); 20 – 180
- Viscosity Range(cp); 100 – 25000
- Pressure range(bar); 2 – 14
- Pressure & Discharge ports; ½", ¾", 1", 1½", 2", 2½", 3", 4", 6"

### MATERIALS;

Main Body: Cast iron

Gears: Steel, Cast Iron, Ductile Iron, Stainless Steel, Industrial Plastics,

Shafts: Steel, Heat Treated Steel

Bushings: Bronze, Carbon, Special Materials, Bearing

Sealing options: Packing, Mechanical Seal, Special Sealing Applications

# HELİS DİŞLİ POMPALAR

## HELICAL GEAR PUMPS

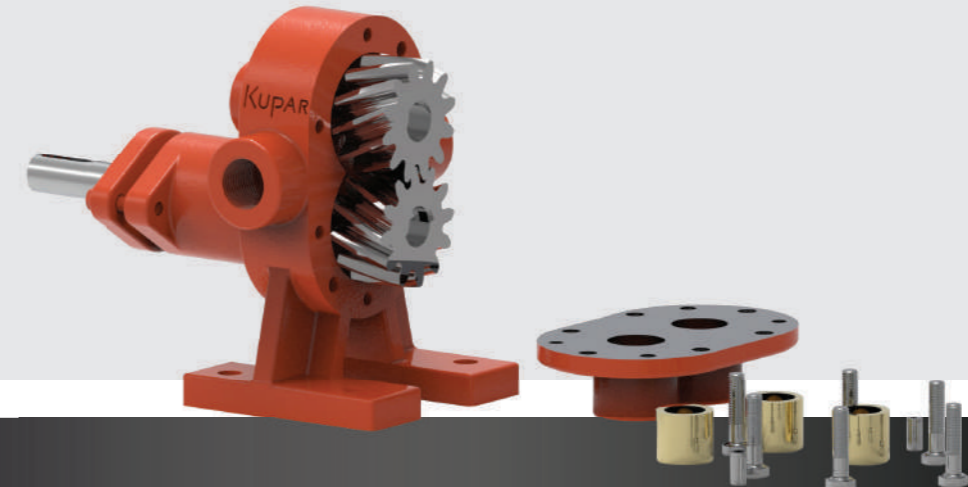
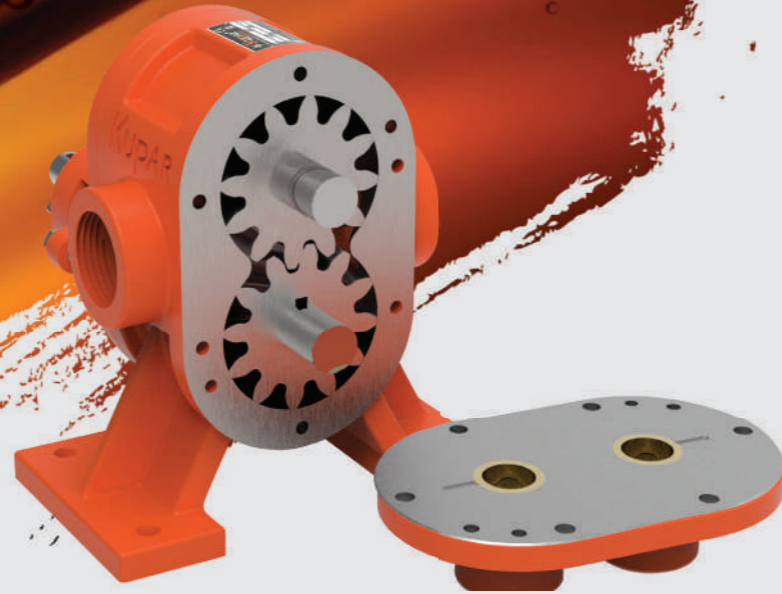





KHP1/2"



KHP3/4"



KHP1"

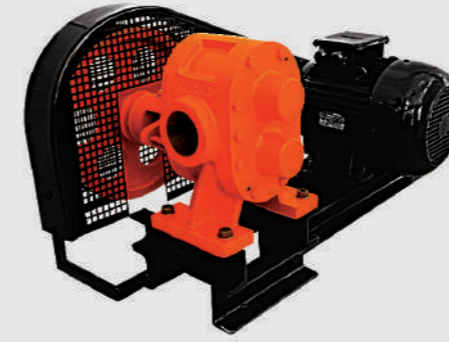

MOTORA KAYIŞ KASNAKLA AKUPLE  
ELECTRIC MOTOR V-BELT DRIVE

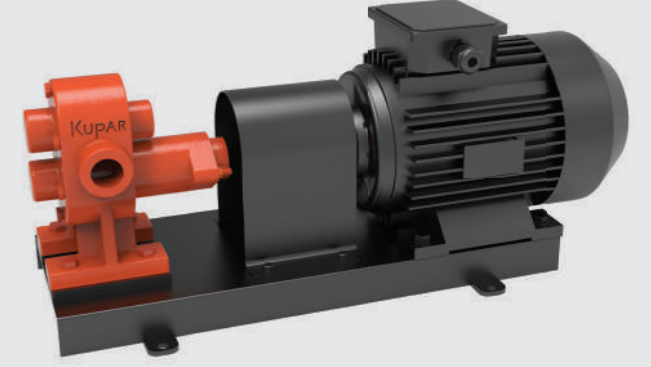

MOTORA DİREK AKUPLE  
ELECTRIC MOTOR DIRECT DRIVE



KHP1 1/2"



KHP2"



KHP2 1/2"

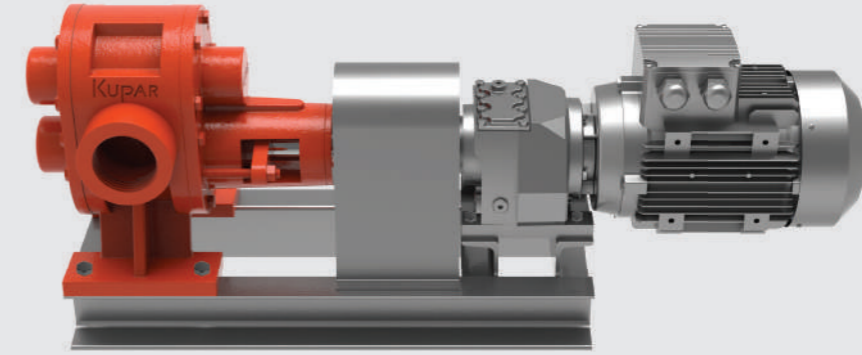

REDÜKTÖRE DİREK AKUPLE  
GEARBOX DIRECT DRIVE

## DONANIMLAR / ACCESSORIES



Tekerlekli Taşıma Ünitesi  
Mobile Unit



By-Pass  
By-Pass



Kapaktan Isıtma  
Jacket On The Head



KHP3"



KHP4"



KHP6"



Filtre  
Filter



Mekanik Salmastra  
Mechanical Seal

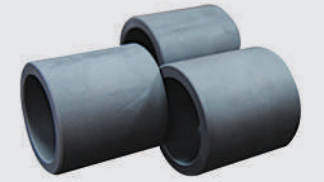

Karbon Yatak  
Carbon Bushing

## KHP1/2"

### ÖZELLİKLER / SPECIFICATIONS

Devir / Speed (rpm)	1.500	1.000	500	
Debi / Flow (L / h)	500	350	190	
Basınç / Pressure (max) (bar)	2,5	2,5	5	2,5
Güç / Power (kW)	0,55	0,37	0,55	0,25
Viskozite / Viscosity (cp)	100		1.000	



## KHP1 1/2"

### ÖZELLİKLER / SPECIFICATIONS

Devir / Speed (rpm)	1.500	1.000	500	
Debi / Flow (m3 / h)	11,5	7,5	4	
Basınç / Pressure (max) (bar)	2,5	2,5	5	2,5
Güç / Power (kW)	3	2,2	3	1,1
Viskozite / Viscosity (cp)	100		5.000	



## KHP3/4"

### ÖZELLİKLER / SPECIFICATIONS

Devir / Speed (rpm)	1.500	1.000	500	
Debi / Flow (m3 / h)	3,4	2,4	1,25	
Basınç / Pressure (max) (bar)	2,5	2,5	5	2,5
Güç / Power (kW)	1,1	0,75	1,1	0,55
Viskozite / Viscosity (cp)	100		1.000	



## KHP2"

### ÖZELLİKLER / SPECIFICATIONS

Devir / Speed (rpm)	1.000	400	100	
Debi / Flow (m3 / h)	25	10	2	
Basınç / Pressure (max) (bar)	2,5	5	2,5	2,5
Güç / Power (kW)	5,5	7,5	3	2,2
Viskozite / Viscosity (cp)	100	1.000	25.000	

## KHP1"

### ÖZELLİKLER / SPECIFICATIONS

Devir / Speed (rpm)	1.500	1.000	500	
Debi / Flow (m3 / h)	5	3,5	2	
Basınç / Pressure (max) (bar)	2,5	2,5	5	2,5
Güç / Power (kW)	1,5	1,1	1,5	0,75
Viskozite / Viscosity (cp)	100		1.000	



## KHP2½"

### ÖZELLİKLER / SPECIFICATIONS

Devir / Speed (rpm)	1.000	400	100
Debi / Flow (m <sup>3</sup> / h)	35	14	3,5
Basınç / Pressure (max) (bar)	2,5	5	2,5
Güç / Power (kW)	11	15	4
Viskozite / Viscosity (cp)	100	25.000	



## KHP4"

### ÖZELLİKLER / SPECIFICATIONS

Devir / Speed (rpm)	1.000	400	100
Debi / Flow (m <sup>3</sup> / h)	75	30	7,5
Basınç / Pressure (max) (bar)	2,5	5	2,5
Güç / Power (kW)	18,5	22	7,5
Viskozite / Viscosity (cp)	100	1.000	25.000



## KHP3"

### ÖZELLİKLER / SPECIFICATIONS

Devir / Speed (rpm)	1.000	400	100
Debi / Flow (m <sup>3</sup> / h)	50	20	5
Basınç / Pressure (max) (bar)	2,5	5	2,5
Güç / Power (kW)	15	18,5	5,5
Viskozite / Viscosity (cp)	100	1.000	25.000



## KHP6"

### ÖZELLİKLER / SPECIFICATIONS

Devir / Speed (rpm)	400	100
Debi / Flow (m <sup>3</sup> / h)	100	25
Basınç / Pressure (max) (bar)	2,5	5
Güç / Power (kW)	30	37
Viskozite / Viscosity (cp)	100	25.000

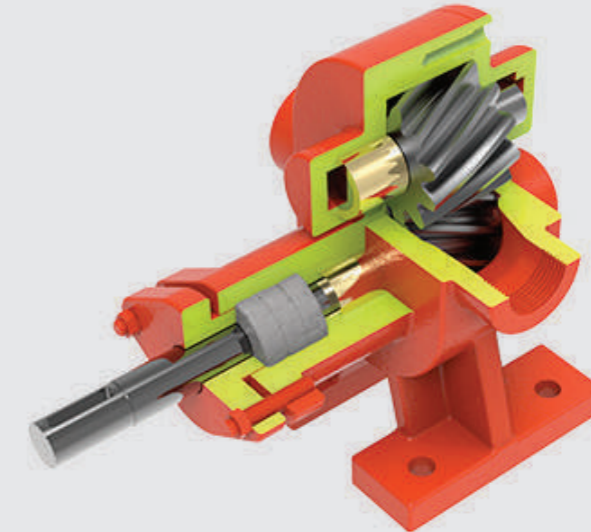
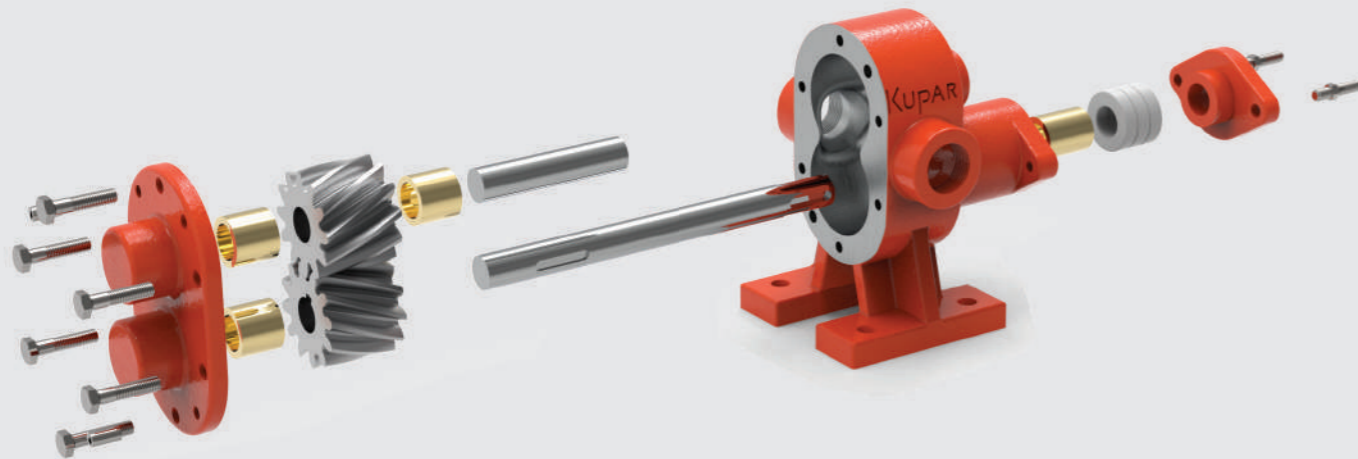

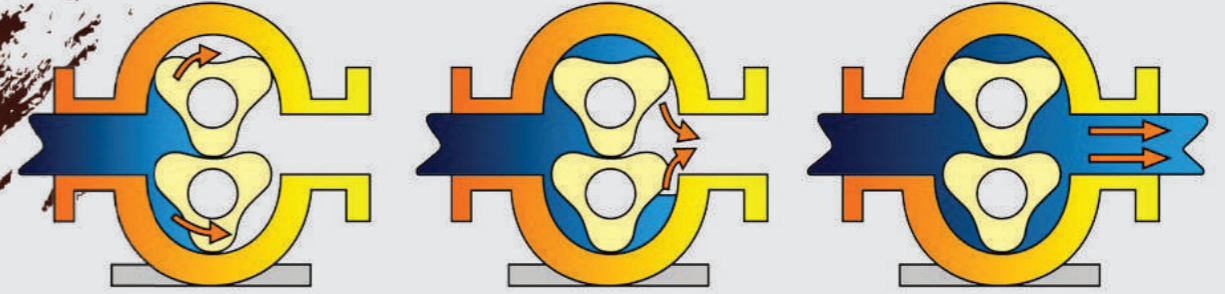

### AVANTAJLARI;

- Yüksek verimlidirler.
- Uzun ömürlüdürler
- Küçük katı parçalı sıvıların transferinde kullanılabilir.
- Kuru çalışabilir.
- Düşük gürültü ve titreşimlidir.
- Bakımı hattan sökülmeden çok kısa sürede ve kolayca yapılabilir.

### PERFORMANS;

Sıcaklık aralığı (°C): 0-150

Viskozite aralığı (cp): 100-50,000

Çıkış basınç aralığı (bar): 1 - 5

Giriş & Çıkış çapları: 1½", 2", 2½" Flanş veya rekorlu

### MALZEMELER:

Ürünle Temas eden Yüzeyler: AISI 304 - AISI 316

Dişli Kutusu: Dökme Demir,

Yataklar: Rulman,

Sızdırmazlık: Mekanik salmastra, Çift Mekanik Salmastra, Keçeli Sistem

### ADVANTAGES;

- High efficient
- Long Life
- Can transfer liquids including small solid particles
- Can run dry for an extended period of time
- Low noise and vibration.
- Can be repaired easily in a short time without demounting.

### PERFORMANCE;

Temperature range (°C): 0-150

Viscosity range (cp): 100-50,000

Pressure range (bar): 1-5

Suction & Pressure ports: 1½", 2", 2½" Flanged or union

### MATERIALS;

Surfaces in contact: AISI 304-316

Gear Box: Cast Iron,

Bushings: Bearing

Sealing options: Mechanical seal, Double Mechanical seal, Lip seals Applications



## LOBLU POMPALAR LOBE PUMPS



**ÇALIŞMA PRENSİBİ**

Loblu Pompa; birbirine ters yönde dönen 2 ayrı shaft, her shaft üzerinde bir lob, bir salmastra, bir zamanlama dişlisi ve yataklamayı sağlayan en az 2 adet rulman bulunmaktadır. Şarflardan bir tanesi motor tarafından direk tahrik edilirken, kuvvet bir öteki shafta zamanlama dişlileri ile aktarılır. Loblar arasında sıvı sızdırmazlığı sağlayacak kadar az boşlukla temas etmeden döner.

İç içe girintili yapıdaki lobların dönüş hareketi, gittikçe genişleyen bir boşluk yaratır. Bu boşluk pompanın emiş tarafında vakum oluşmasını sağlar. Bu sayede akışkan ve içindeki parçacıklar, pompanın emiş hattına doğru hareketlenir, pompanın içine gelir. Loblar akışkanı alt ve üst gövde boşlukları boyunca taşıyarak pompanın çıkış hattına aktarır. Bu noktada tekrar iç içe geçen loblar pozitif basınç yaratarak akışkanı çıkış hattı boyunca öter ve aktarır.

**WORKING PRINCIPLE;**

Lobe Pump includes two separate shafts rotating in the opposite direction to each other, a Lobe, a seal, a timing gear and minimum 2 bearings for bushing on each shaft.

One of the shaft is driven by the motor, the motion is transmitted to other shaft by timing gear. Lobes rotate with the clearances so there is no contact between each other and the body. These clearances are designed to not to allow leakage viscous liquids between the lobes and body. During the rotation of the lobes; because of a growing gap at the suction side, vacuum occurs. Because of this vacuum; the liquid comes inside the pump, then lobes transport the liquid by the help of gaps between the lobes and body. At the discharge side, when the lobes meet a positive pressure occurs. This pressure pushes the liquid outside the pump.

**KLP1½"**
**ÖZELLİKLER / SPECIFICATIONS**

Devir / Speed / (rpm) 100 250	100	250		
Debi / Flow / (m3 / h)	0,75	2		
Basınç / Pressure / (max) (bar)	2,5	5	2,5	5
Güç / Power / (kW)	0,55	0,75	1,1	1,5
Viskozite / Viscosity / (cp)	30.000	5.000		

**KLP2"**
**ÖZELLİKLER / SPECIFICATIONS**

Devir / Speed / (rpm) 100 250	100	250		
Debi / Flow / (m3 / h)	2	5		
Basınç / Pressure / (max) (bar)	2,5	5	2,5	5
Güç / Power / (kW)	1,1	1,5	2,2	3
Viskozite / Viscosity / (cp)	30.000	5.000		

**KLP2½"**
**ÖZELLİKLER / SPECIFICATIONS**

Devir / Speed / (rpm) 100 250	100	250		
Debi / Flow / (m3 / h)	4	10		
Basınç / Pressure / (max) (bar)	2,5	5	2,5	5
Güç / Power / (kW)	2,2	3	4	5,5
Viskozite / Viscosity / (cp)	30.000	5.000		





## PASLANMAZ ve BRONZ POMPALAR STAINLESS STEEL & BRONZE PUMPS

### MALZEMELER

- Dış gövde: AISI316, AISI304 Paslanmaz Çelik döküm, Bronz Döküm
- Dişliler: AISI316, AISI304 Paslanmaz Çelik, Bronz, Sert Sanayi Plastikleri,
- Miller: AISI316, AISI420 Paslanmaz Çelik,
- Yataklama: Bronz, Karbon, Rulman
- Sızdırmazlık: Yumuşak Salmastra, Mekanik Salmastra, Özel Tasarım Sızdırmazlık Sistemleri.

### MATERIALS:

- Main Body: AISI316, AISI304 Cast Stainless Steel, Cast Bronze
- Gears: AISI316, AISI304 Stainless Steel, Bronze
- Shafts: AISI316, AISI420 Stainless Steel
- Bushings: Bronze, Carbon, Special Materials, Bearing
- Sealing options: Packing, Mechanical Seal, Special Sealing Applications



KHP1/2"-C

AISI316



KHP1"-B

BRONZ



KHP1"-C

AISI316



KHP1/2"-B

BRONZ



KHP1/2"-C

AISI316



KHP2"-B

BRONZ



KHP2"-C

AISI316



KHP2/2"-B

BRONZ



KHP2/2"-C

AISI316

**KHP1/2"-C**

**ÖZELLİKLER / SPECIFICATIONS**

Devir / Speed (rpm)	1.500	1.000	500	
Debi / Flow (m3 / h)	500	350	190	
Basınç / Pressure (max) (bar)	2,5	2,5	5	2,5
Güç / Power (kW)	0,55	0,37	0,55	0,25
Viskozite / Viscosity (cp)	100		1.000	



**KHP2"-B**

**ÖZELLİKLER / SPECIFICATIONS**

Devir / Speed (rpm)	1.000	400	100	
Debi / Flow (m3 / h)	25	10	2	
Basınç / Pressure (max) (bar)	2,5	5	2,5	2,5
Güç / Power (kW)	5,5	7,5	3	2,2
Viskozite / Viscosity (cp)	100	1.000	25.000	



**KHP2"-C**

**KHP1"-B**

**ÖZELLİKLER / SPECIFICATIONS**

Devir / Speed (rpm)	1.500	1.000	500	
Debi / Flow (m3 / h)	5	3,5	2	
Basınç / Pressure (max) (bar)	2,5	2,5	5	2,5
Güç / Power (kW)	1,5	1,1	1,5	0,75
Viskozite / Viscosity (cp)	100		1.000	

**KHP1"-C**



**KHP2 1/2"-C**

**ÖZELLİKLER / SPECIFICATIONS**

Devir / Speed (rpm)	1.000	400	100	
Debi / Flow (m3 / h)	35	14	3,5	
Basınç / Pressure (max) (bar)	2,5	5	2,5	2,5
Güç / Power (kW)	11	15	4	3
Viskozite / Viscosity (cp)	100	25.000		

**KHP1 1/2"-B**

**ÖZELLİKLER / SPECIFICATIONS**

Devir / Speed (rpm)	1.500	1.000	500	
Debi / Flow (m3 / h)	11,5	7,5	4	
Basınç / Pressure (max) (bar)	2,5	2,5	5	2,5
Güç / Power (kW)	3	2,2	3	1,1
Viskozite / Viscosity (cp)	100		5.000	

**KHP1 1/2"-C**



**KHP3"-C**

**ÖZELLİKLER / SPECIFICATIONS**

Devir / Speed (rpm)	1.000	400	100	
Debi / Flow (m3 / h)	50	20	5	
Basınç / Pressure (max) (bar)	2,5	5	2,5	2,5
Güç / Power (kW)	15	18,5	5,5	4
Viskozite / Viscosity (cp)	100	1.000	25.000	



## KIPK $\frac{3}{8}$ " İÇ DİŞLİ POMPA PERFORMANS EĞRİLERİ

### 1- Devir - Debi

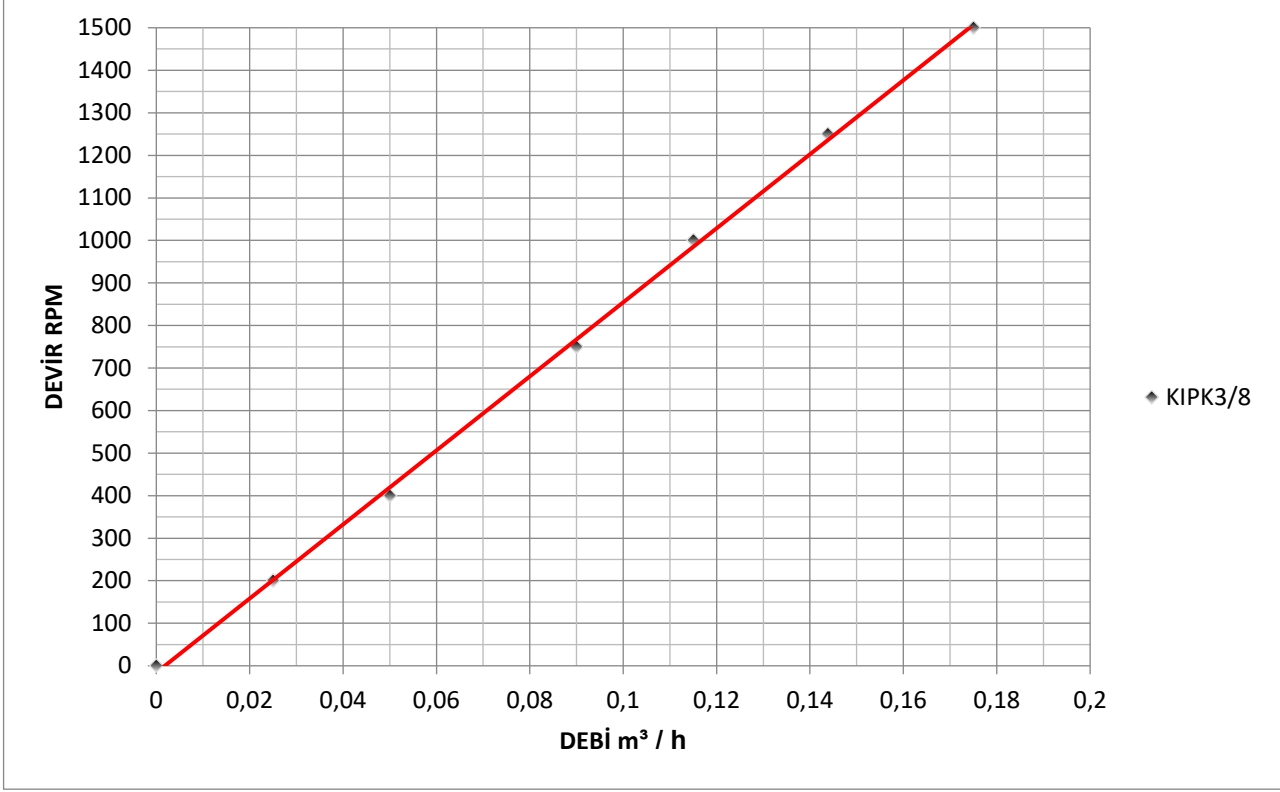

### 2- Devir - Güç - Basınç

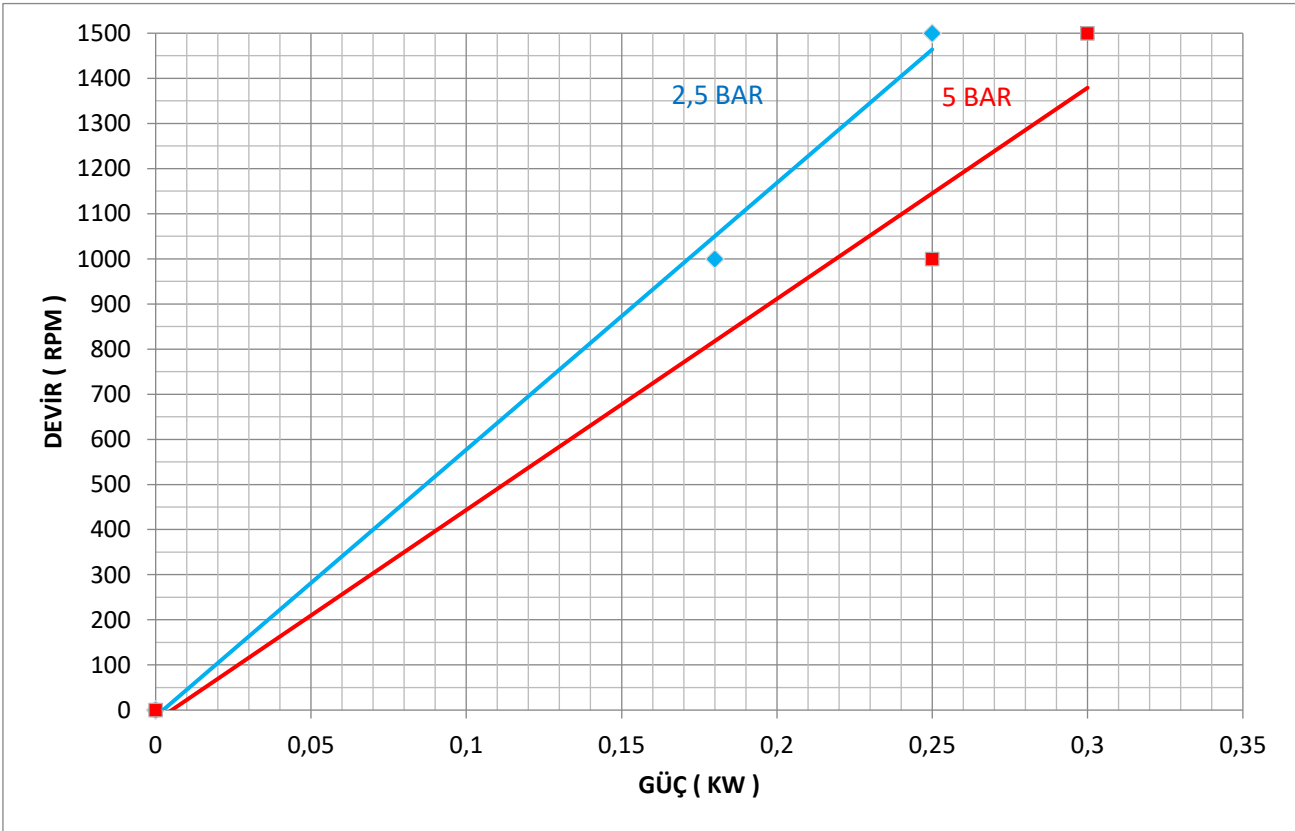

TESTLER SAE30 YAĞ İLE ODA SICAKLIĞINDA ( YAKLAŞIK 100 CST) YAPILMIŞTIR.



## KIP<sup>3</sup>/<sub>8</sub>" İÇ DİŞLİ POMPA PERFORMANS EĞRİLERİ

### 1- Devir - Debi

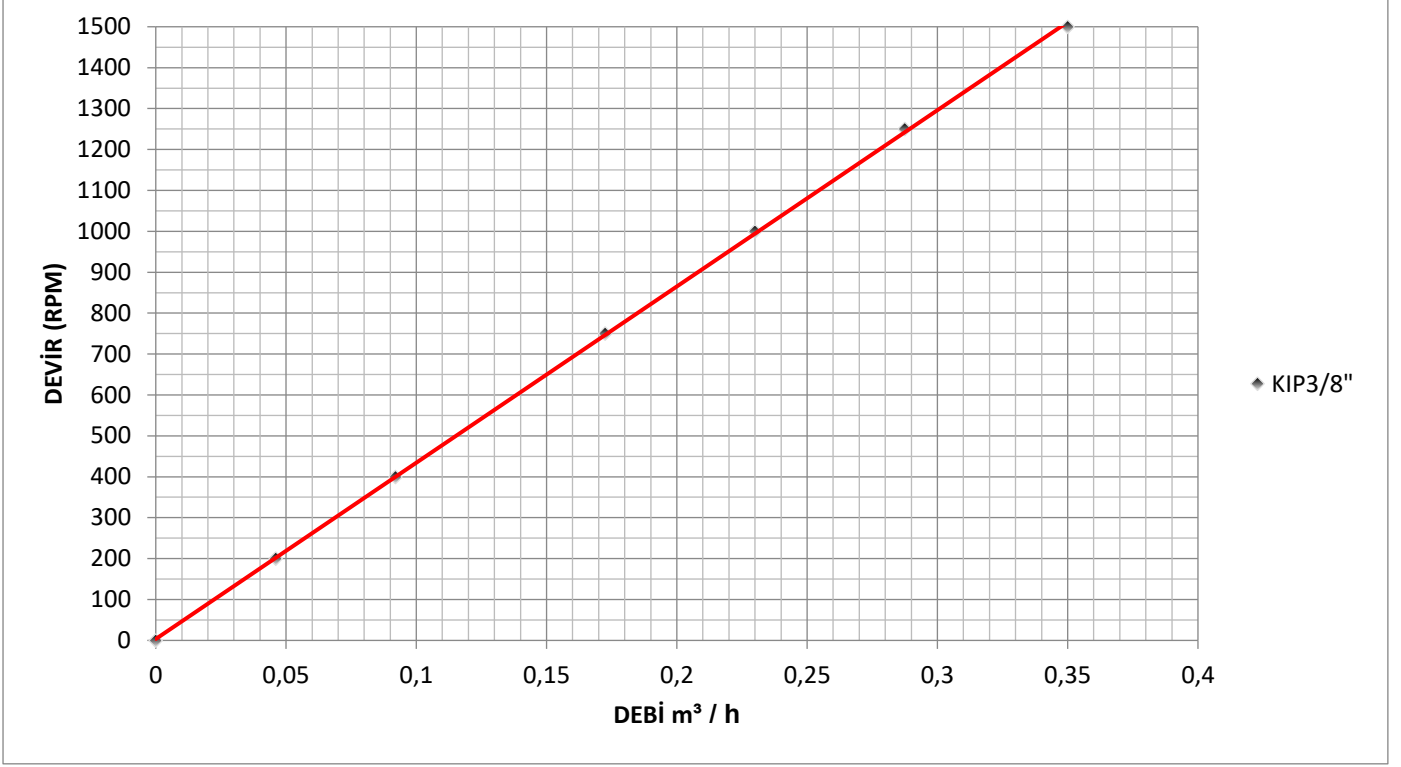

### 2- Devir - Güç - Basınç

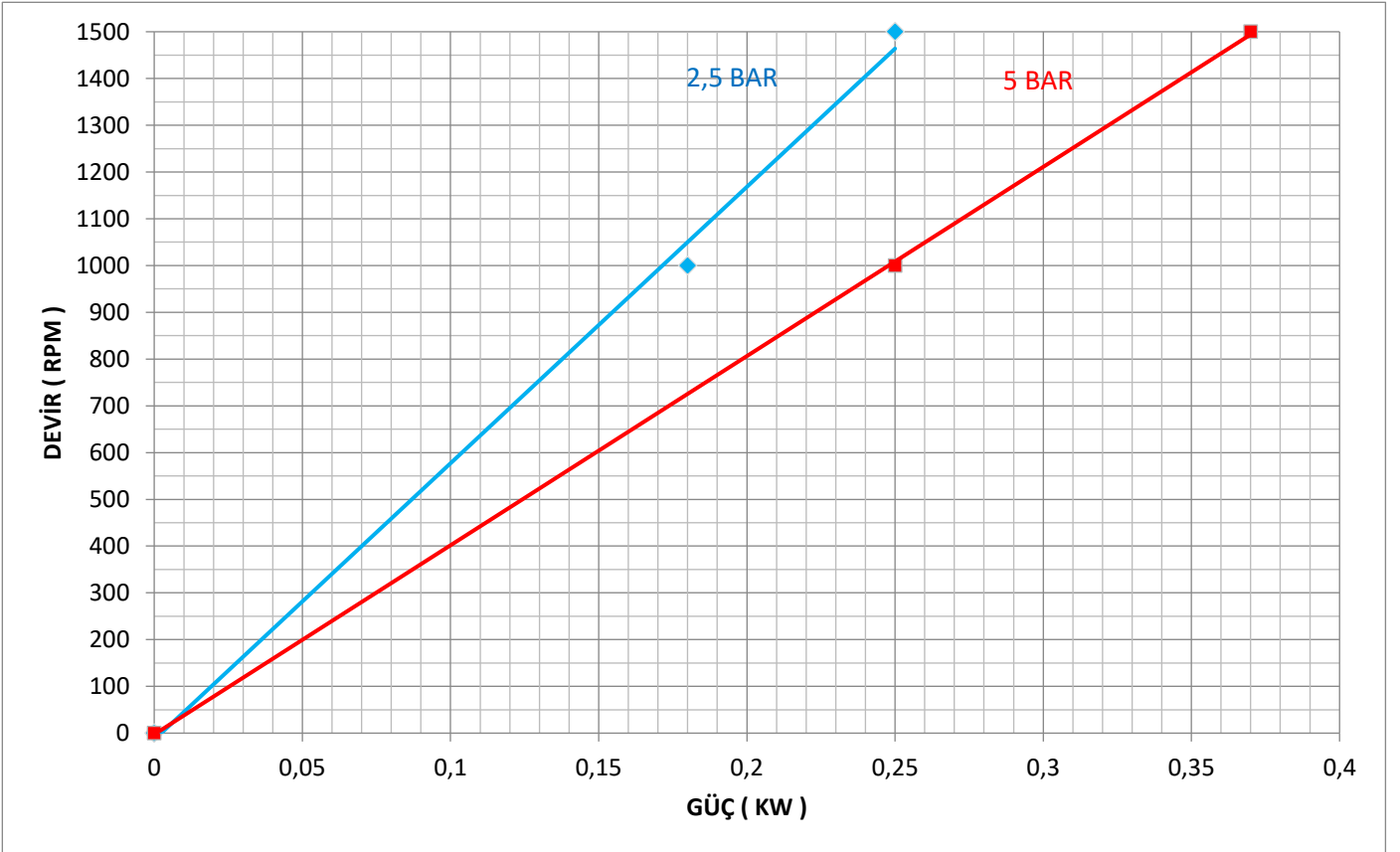

TESTLER SAE30 YAĞ İLE ODA SICAKLIĞINDA ( YAKLAŞIK 100 CST) YAPILMIŞTIR.

## KIPK½" İÇ DİŞLİ POMPA PERFORMANS EĞRİLERİ

### 1- Devir - Debi

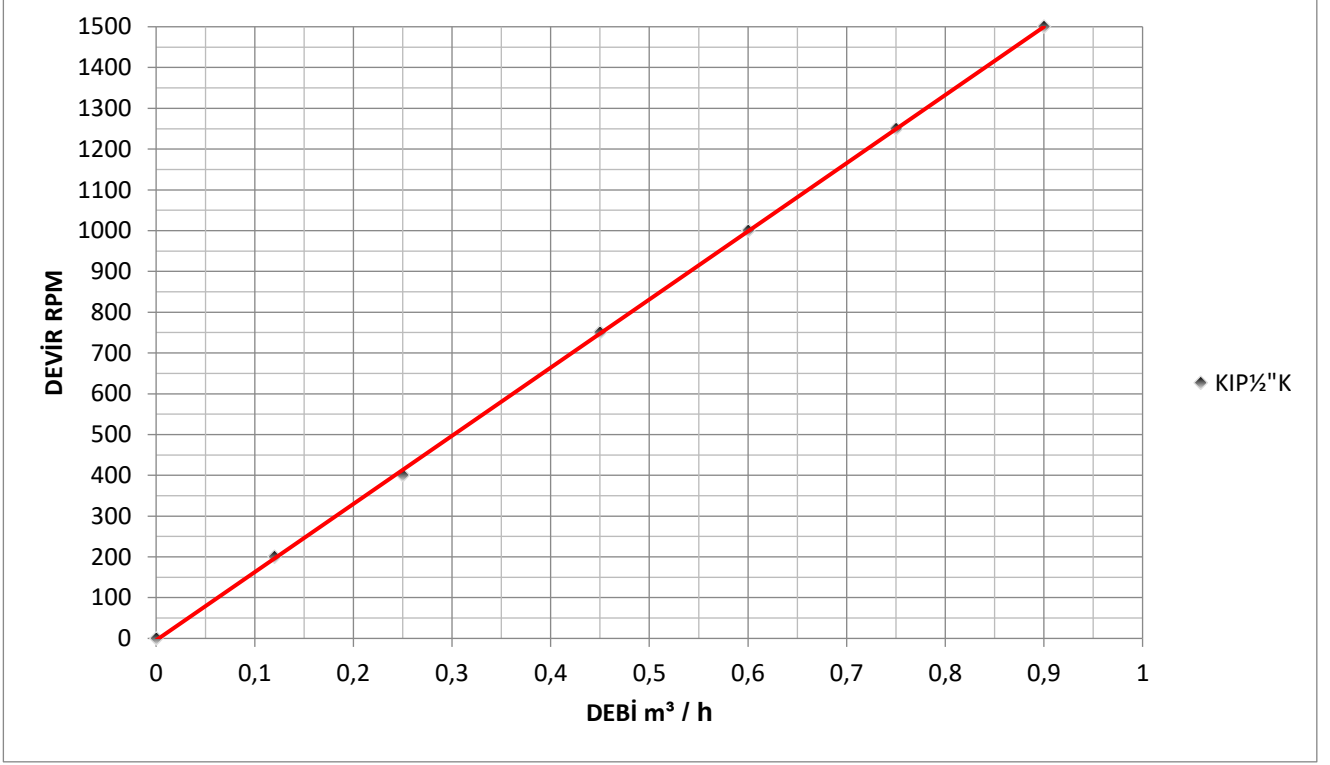

### 2- Devir - Güç - Basınç

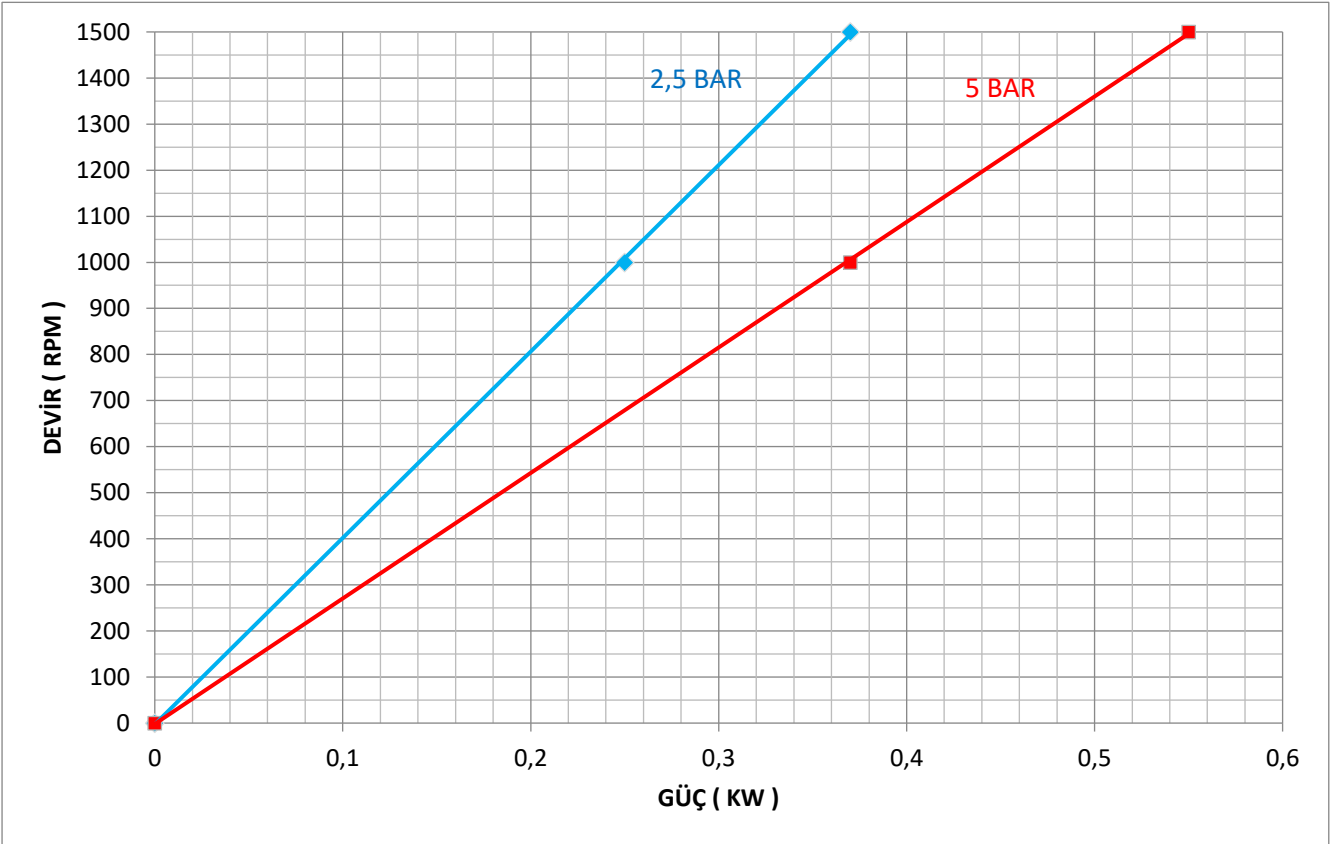

TESTLER SAE30 YAĞ İLE ODA SICAKLIĞINDA ( YAKLAŞIK 100 CST) YAPILMIŞTIR.

## KIP½" İÇ DİŞLİ POMPA PERFORMANS EĞRİLERİ

### 1- Devir - Debi

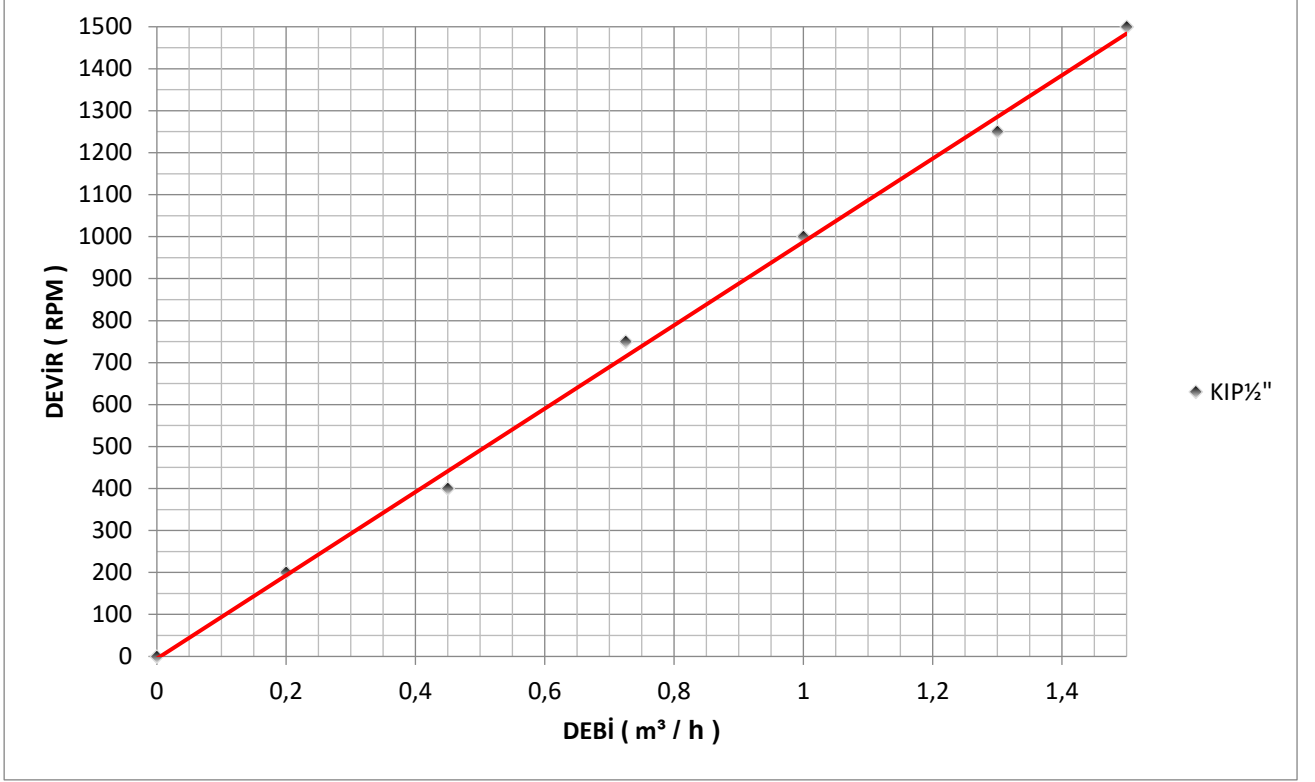

### 2- Devir - Güç - Basınç

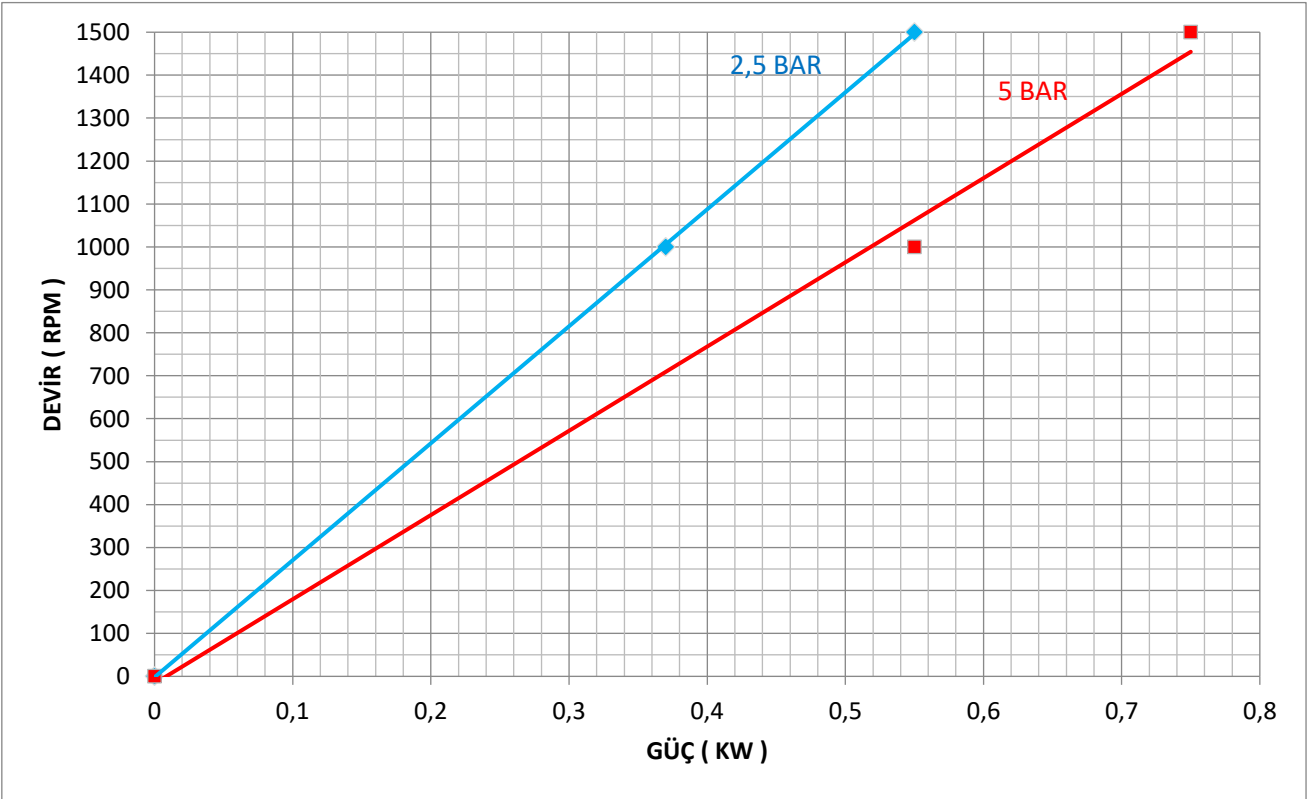

TESTLER SAE30 YAĞ İLE ODA SICAKLIĞINDA (YAKLAŞIK 100 CST) YAPILMIŞTIR.

## KIP1" İÇ DİŞLİ POMPA PERFORMANS EĞRİLERİ

### 1- Devir - Debi

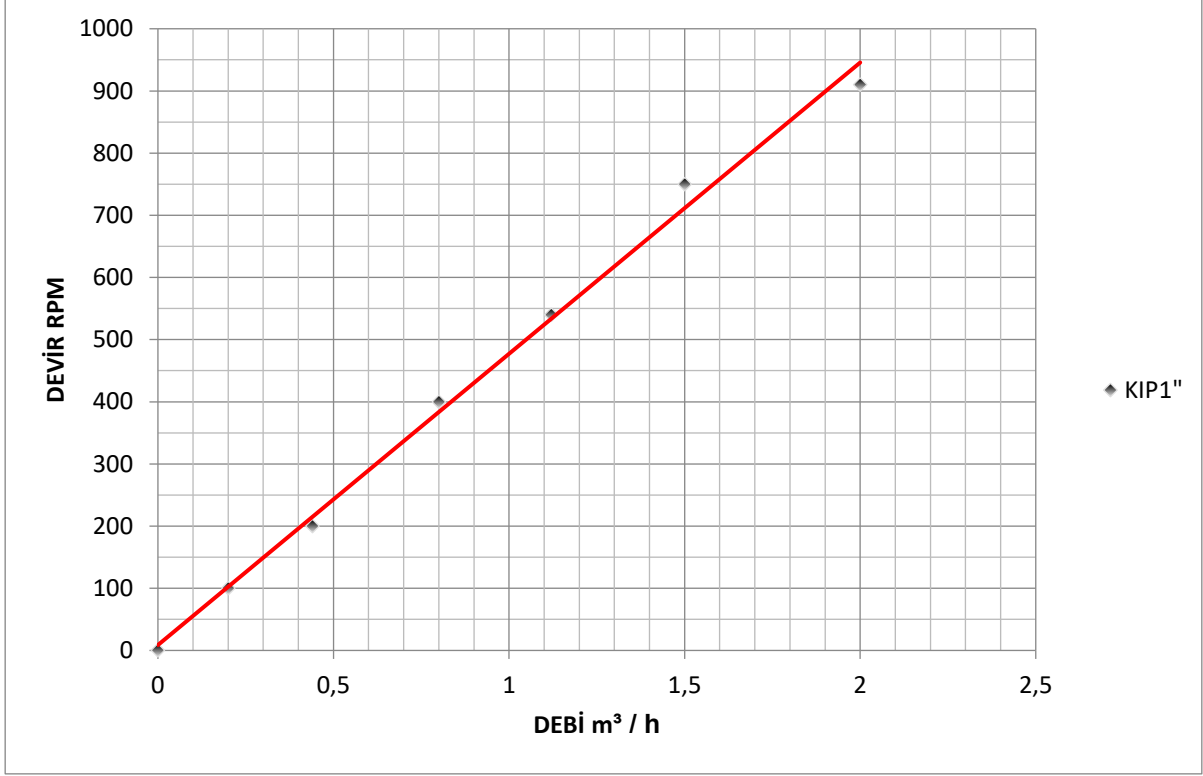

### 2- Devir - Güç - Basınç

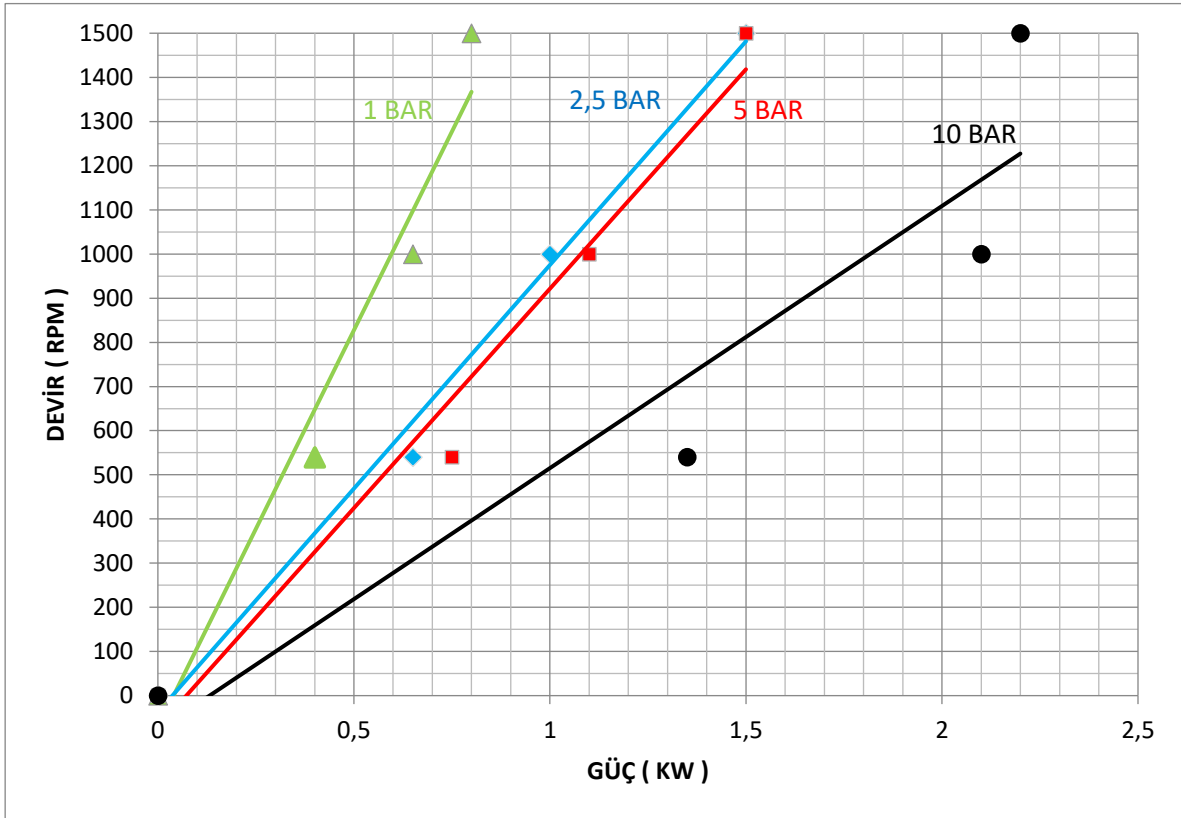

TESTLER SAE30 YAĞ İLE ODA SICAKLIĞINDA ( YAKLAŞIK 100 CST) YAPILMIŞTIR.

## KIP1"-Y İÇ DİŞLİ POMPA PERFORMANS EĞRİLERİ

### 1- Devir - Debi

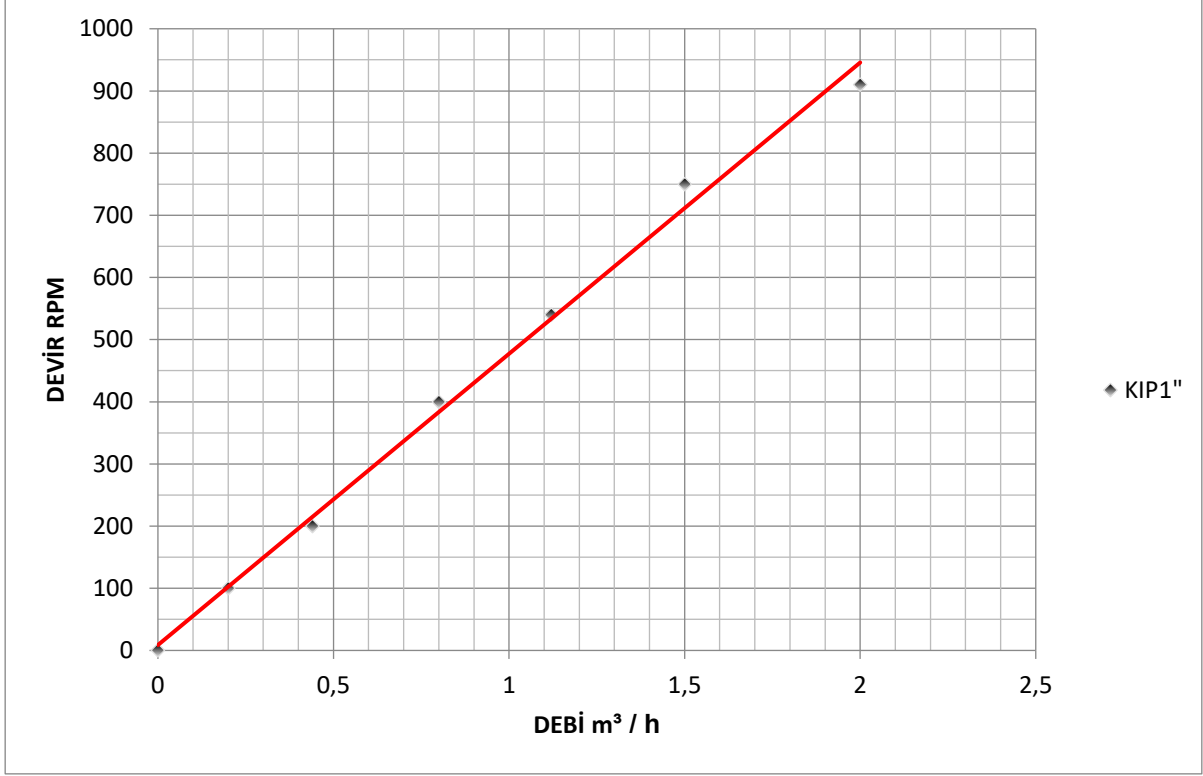

### 2- Devir - Güç - Basınç

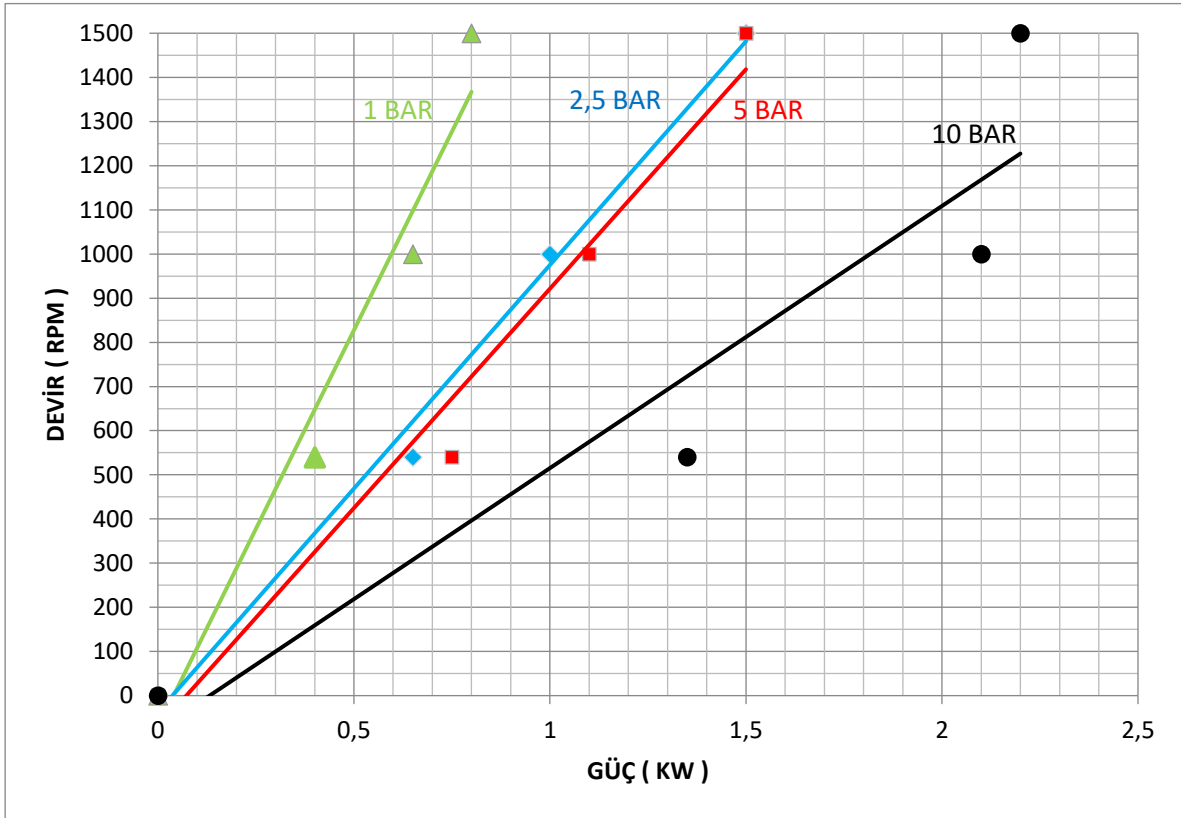

TESTLER SAE30 YAĞ İLE ODA SICAKLIĞINDA ( YAKLAŞIK 100 CST) YAPILMIŞTIR.

## KIPK1½" İÇ DİŞLİ POMPA PERFORMANS EĞRİLERİ

### 1- Devir - Debi

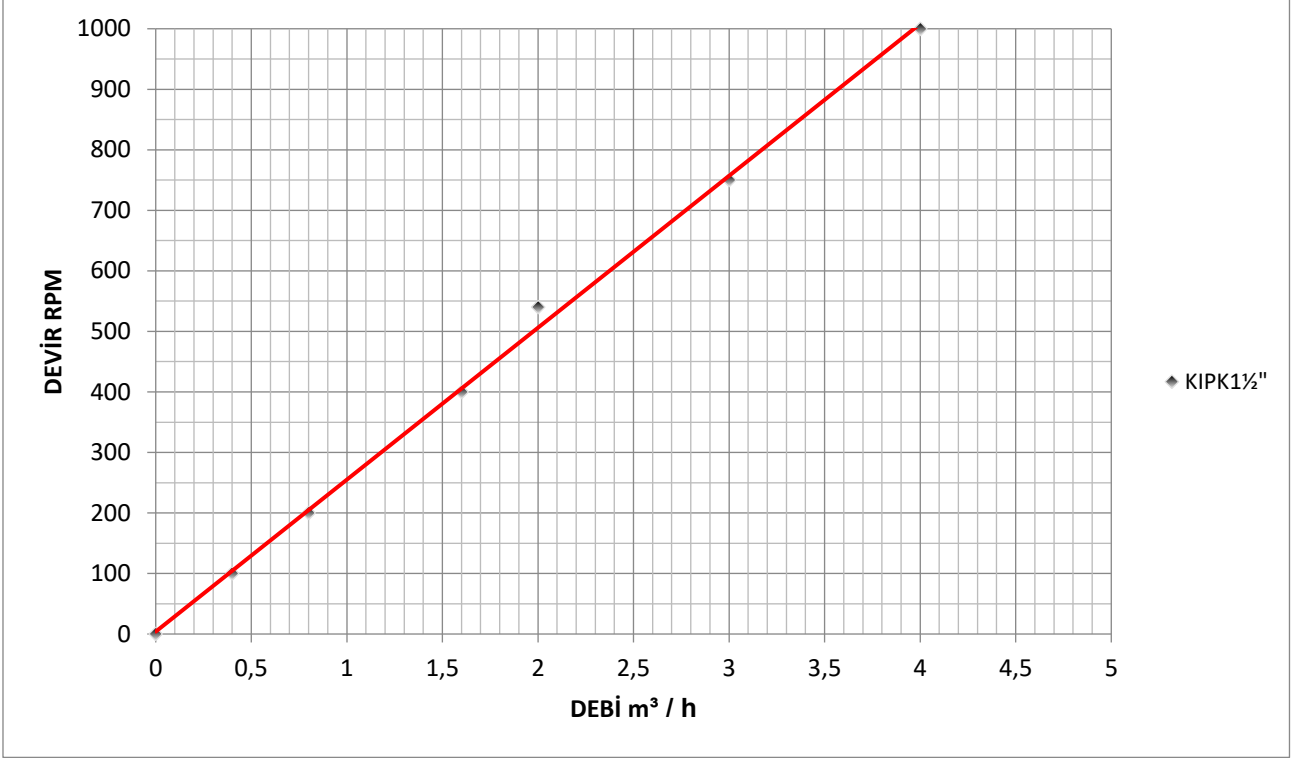

### 2- Devir - Güç - Basınç

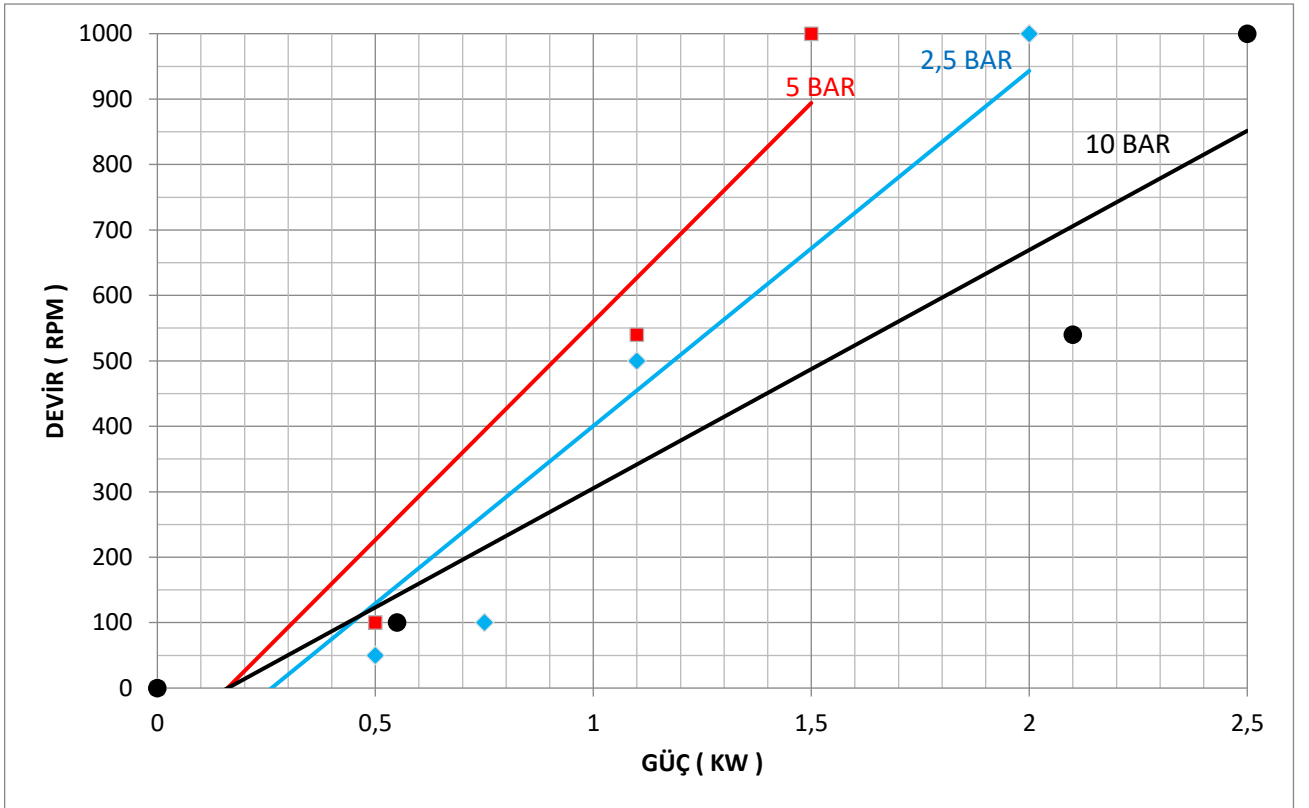

TESTLER SAE30 YAĞ İLE ODA SICAKLIĞINDA ( YAKLAŞIK 100 CST) YAPILMIŞTIR.

## KIPK1½"-Y İÇ DİŞLİ POMPA PERFORMANS EĞRİLERİ

### 1- Devir - Debi

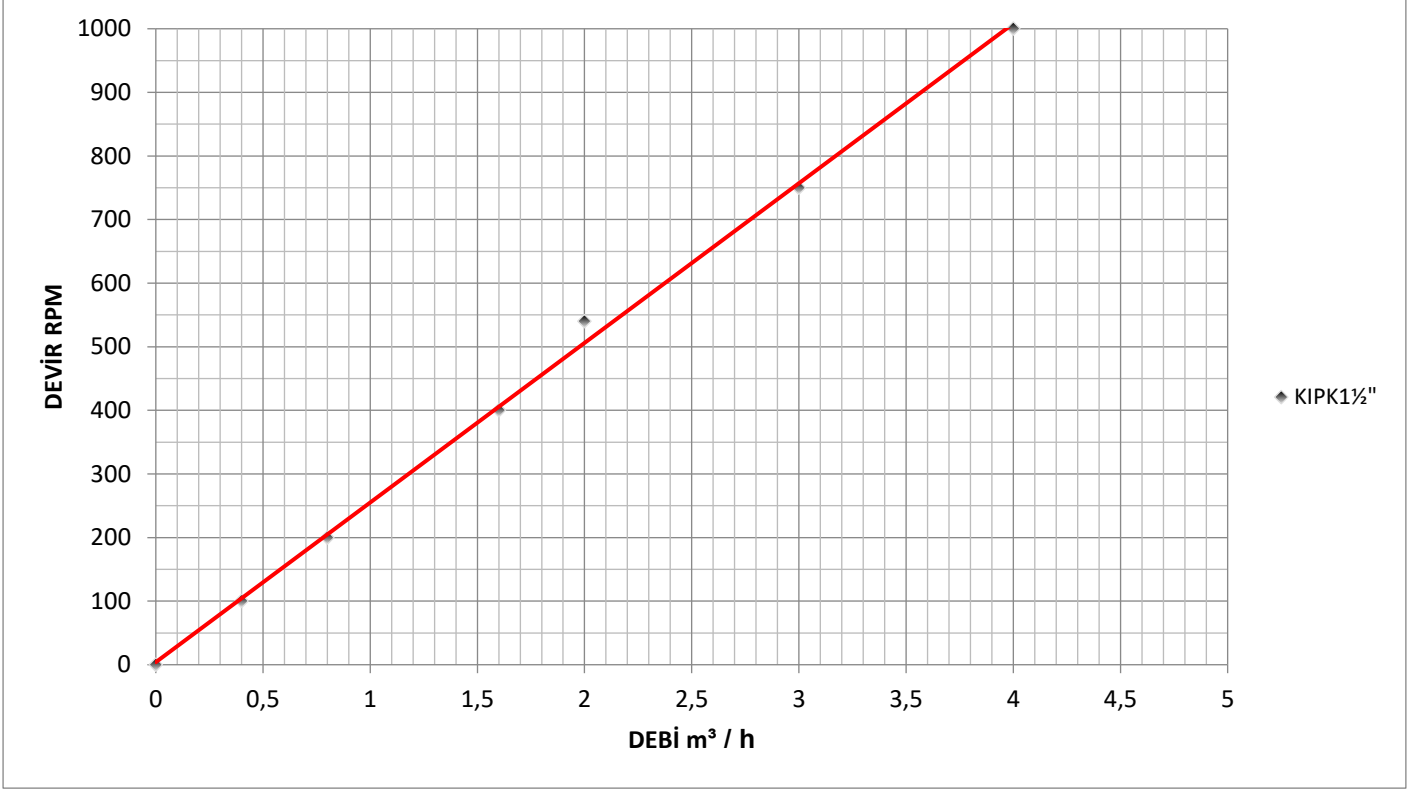

### 2- Devir - Güç - Basınç

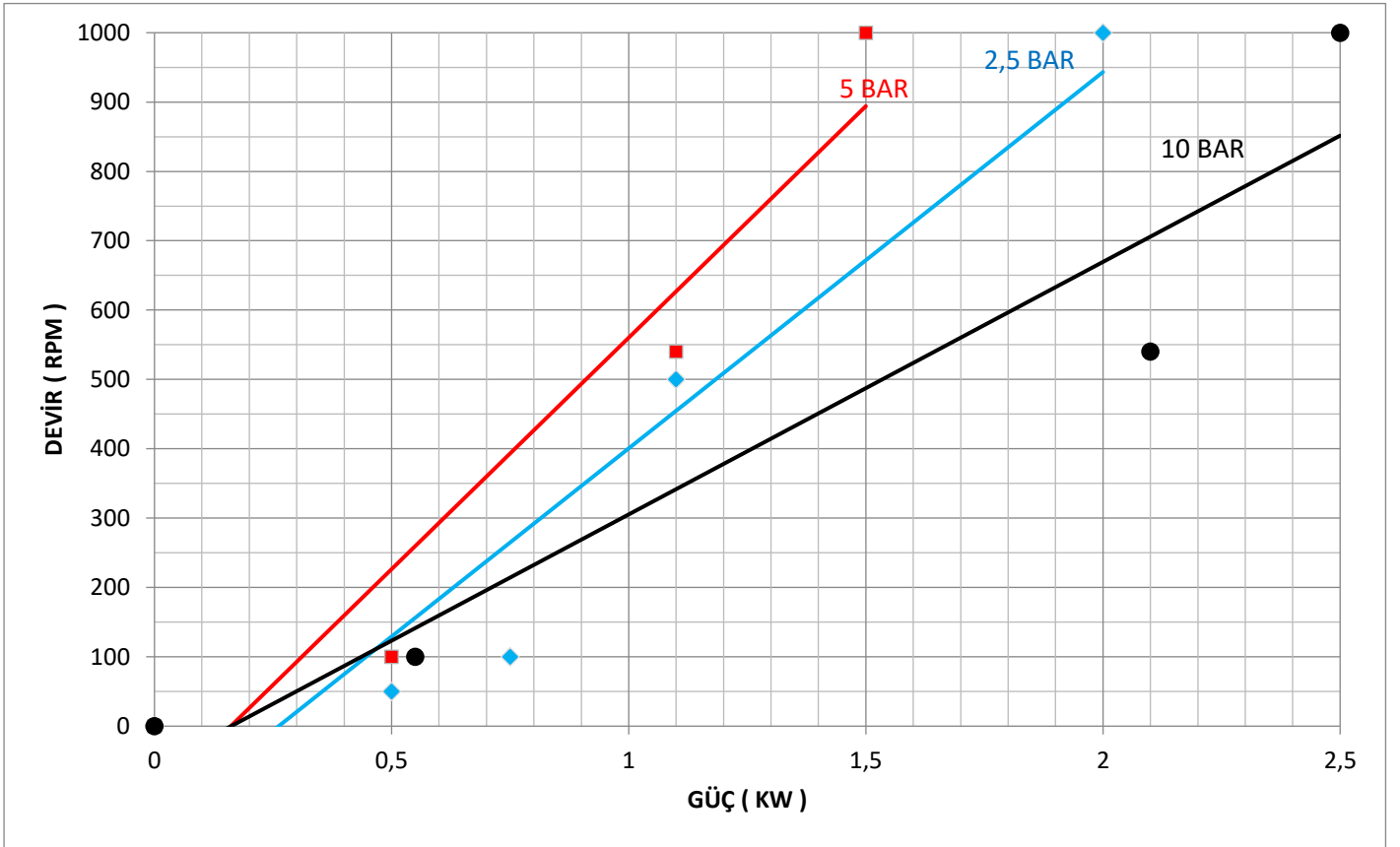

TESTLER SAE30 YAĞ İLE ODA SICAKLIĞINDA (YAKLAŞIK 100 CST) YAPILMIŞTIR.

## KIPK1½" İÇ DİŞLİ POMPA PERFORMANS EĞRİLERİ

### 1- Devir - Debi

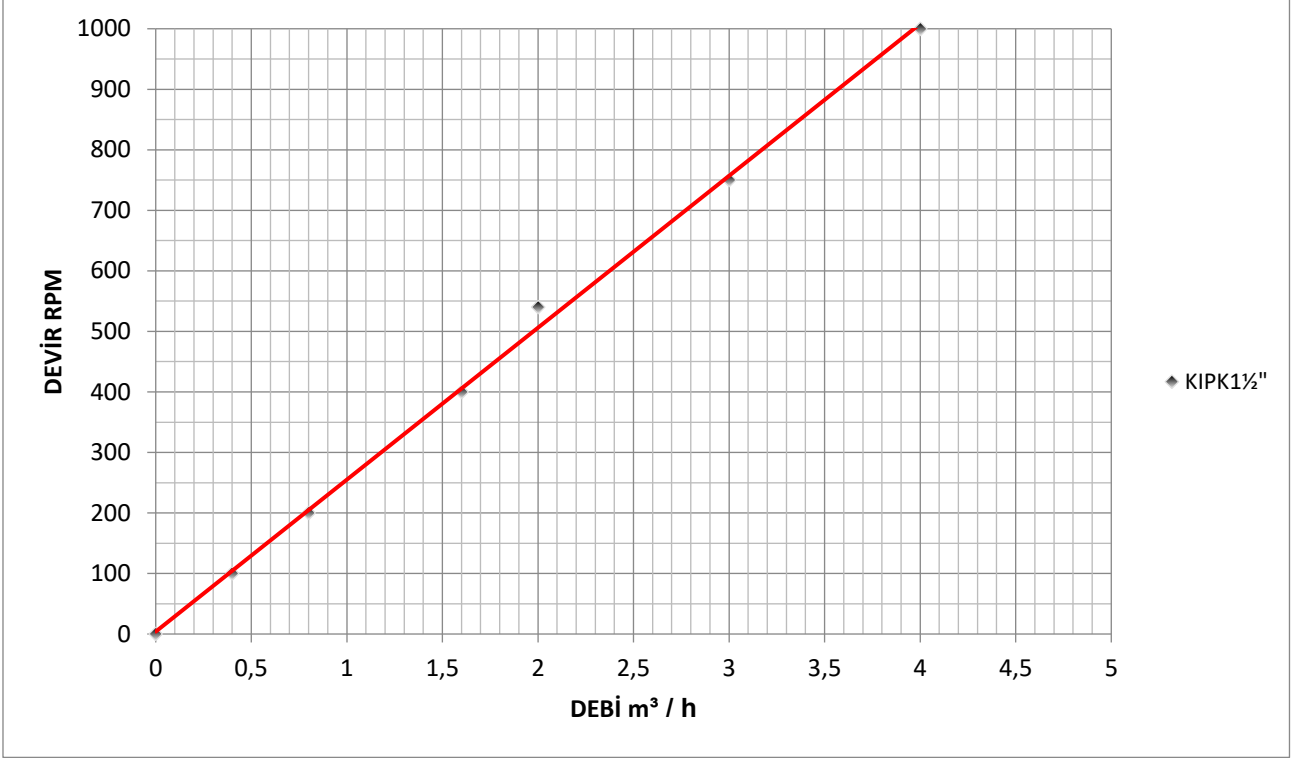

### 2- Devir - Güç - Basınç

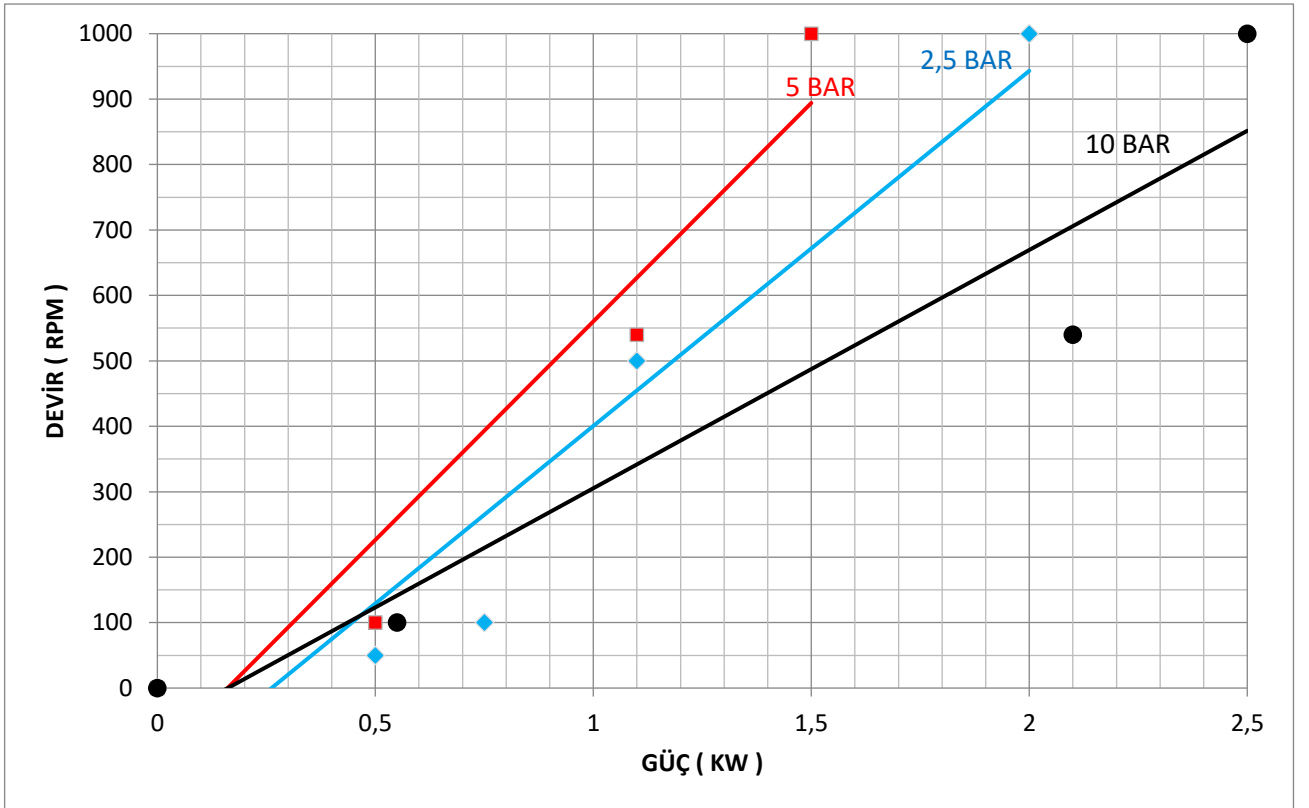

TESTLER SAE30 YAĞ İLE ODA SICAKLIĞINDA (YAKLAŞIK 100 CST) YAPILMIŞTIR.



## KIPK2" İÇ DİŞLİ POMPA PERFORMANS EĞRİLERİ

### 1- Devir - Debi

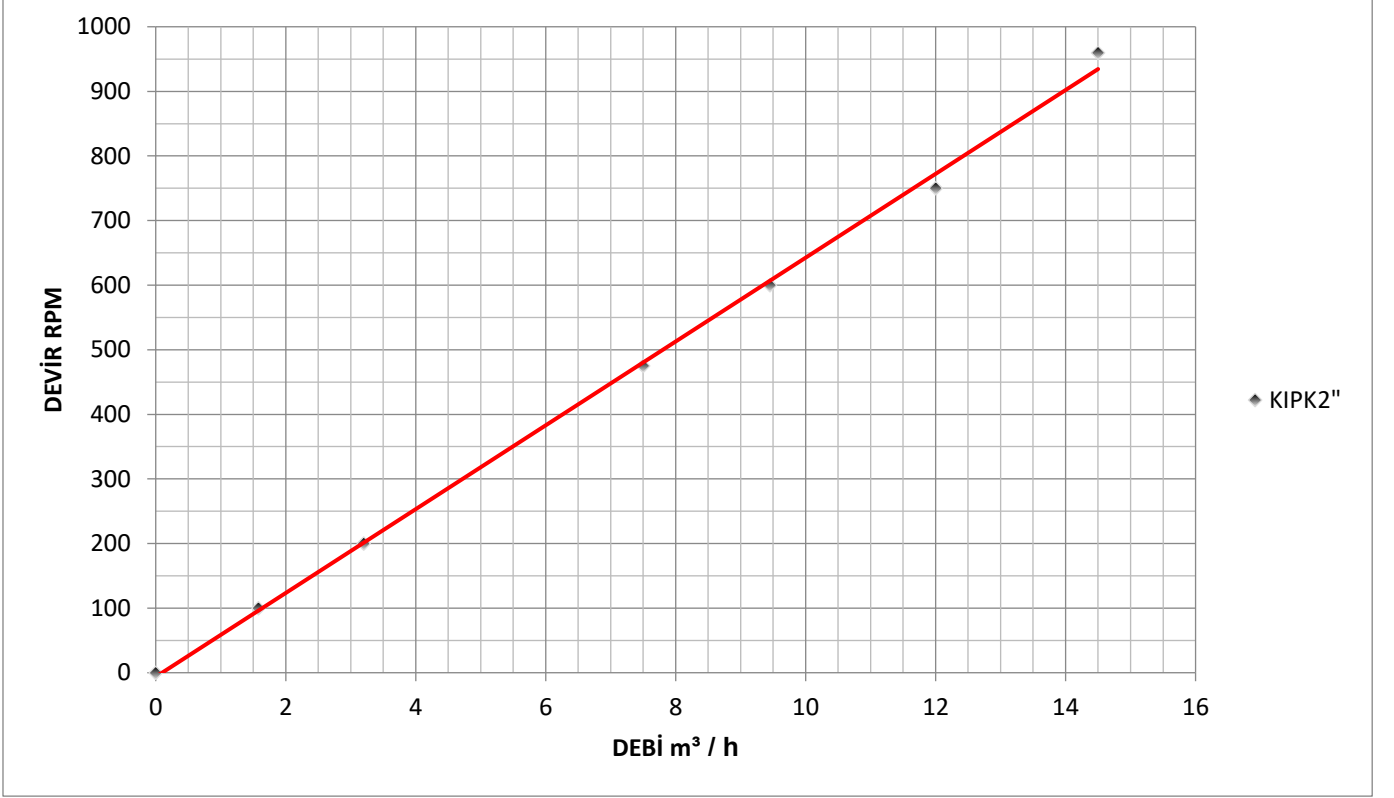

### 2- Devir - Güç - Basınç

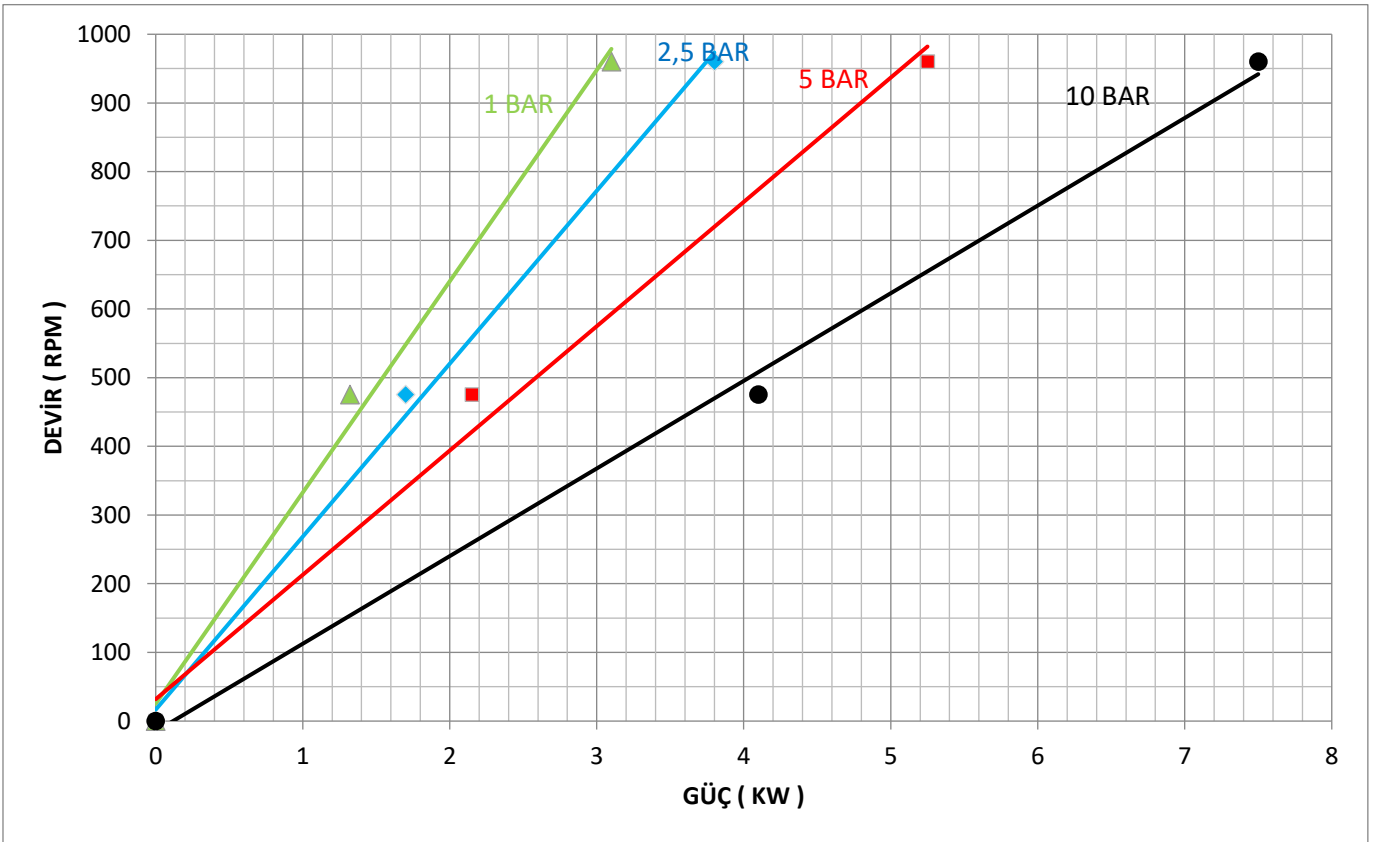

TESTLER SAE30 YAĞ İLE ODA SICAKLIĞINDA (YAKLAŞIK 100 CST) YAPILMIŞTIR.

## KIP2" İÇ DİŞLİ POMPA PERFORMANS EĞRİLERİ

### 1- Devir - Debi

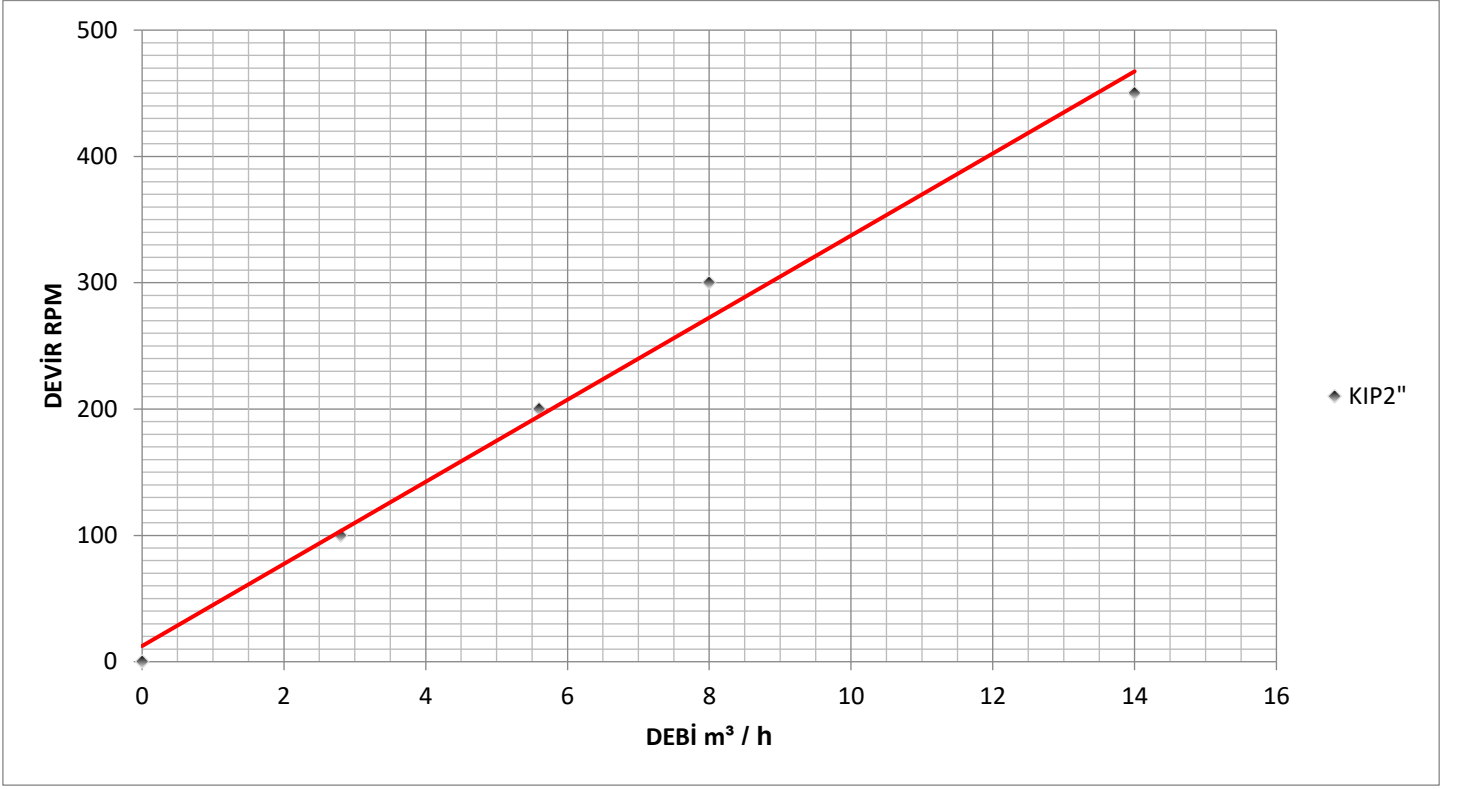

### 2- Devir - Güç - Basınç

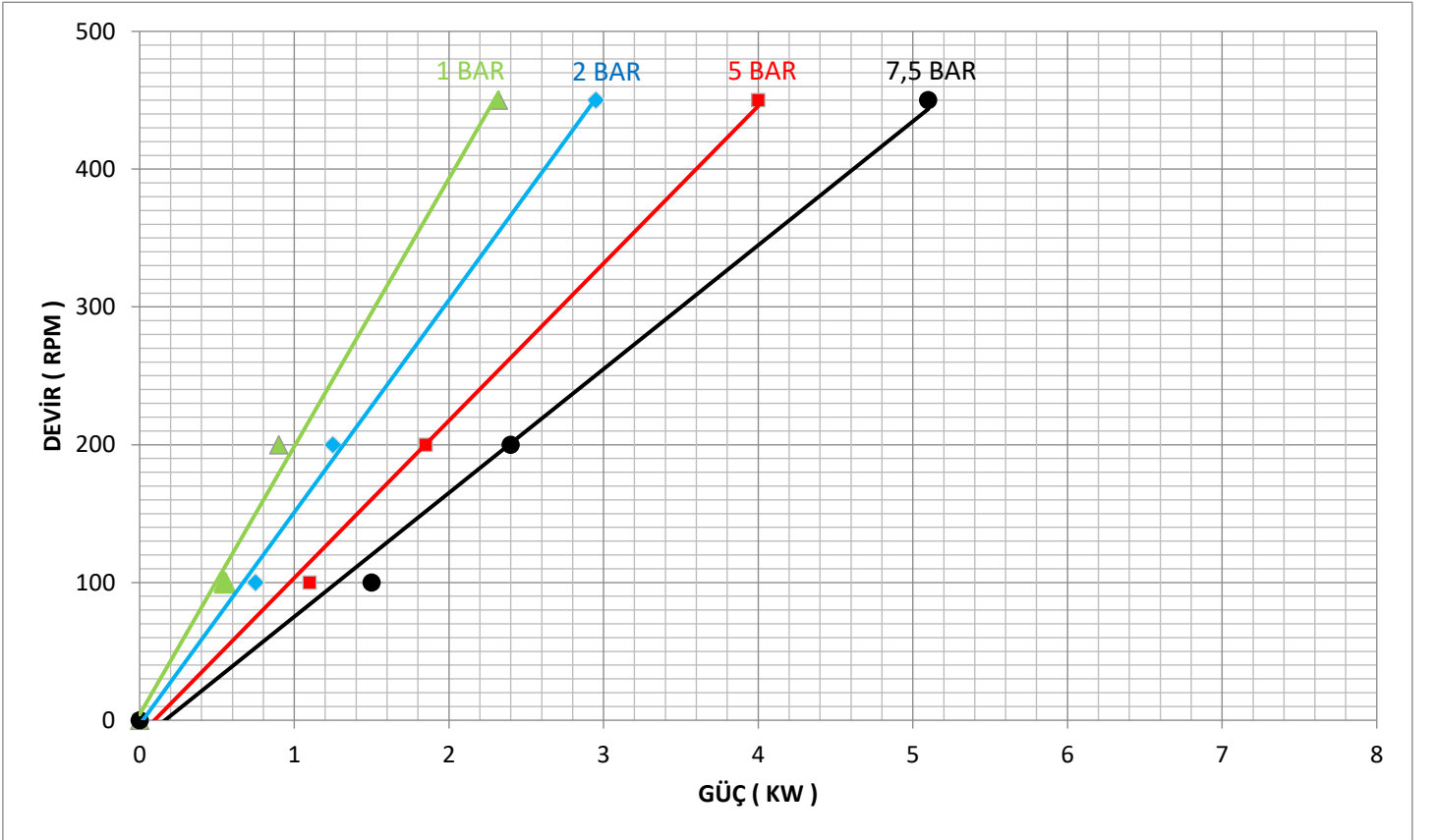

TESTLER SAE30 YAĞ İLE ODA SICAKLIĞINDA ( YAKLAŞIK 100 CST) YAPILMIŞTIR.

## KIP2"-Y İÇ DİŞLİ POMPA PERFORMANS EĞRİLERİ

### 1- Devir - Debi



### 2- Devir - Güç - Basınç

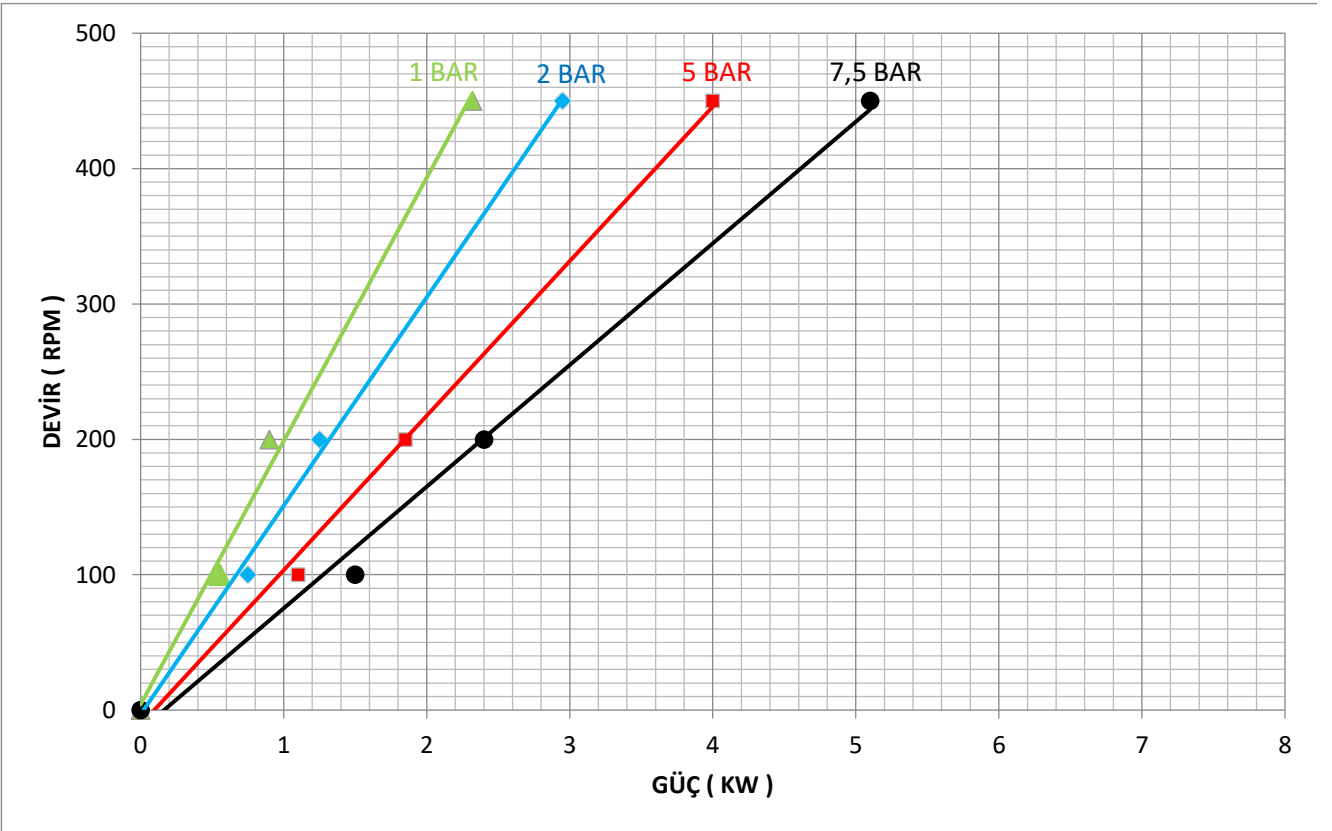

TESTLER SAE30 YAĞ İLE ODA SICAKLIĞINDA ( YAKLAŞIK 100 CST ) YAPILMIŞTIR.

## KIPK2½" İÇ DİŞLİ POMPA PERFORMANS EĞRİLERİ

### 1- Devir - Debi

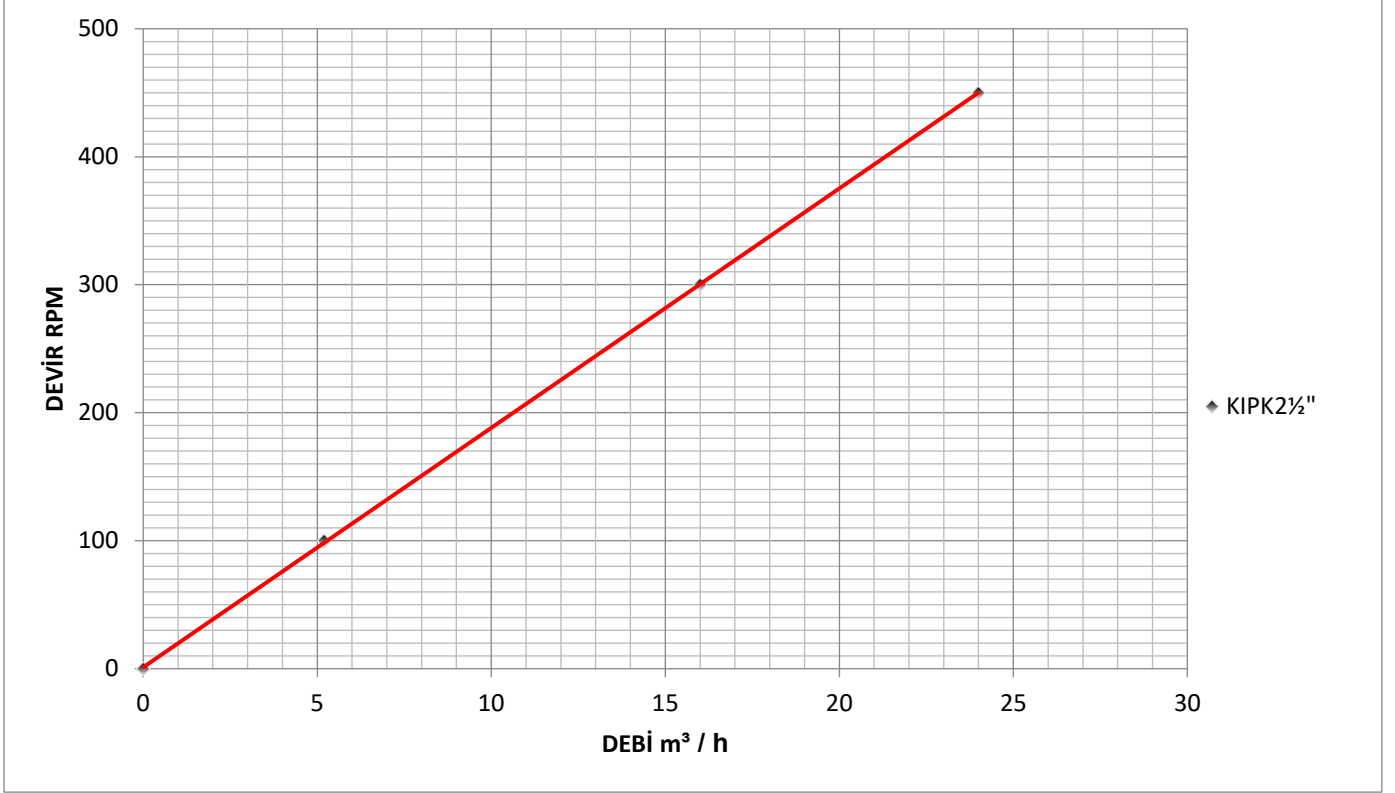

### 2- Devir - Güç - Basınç

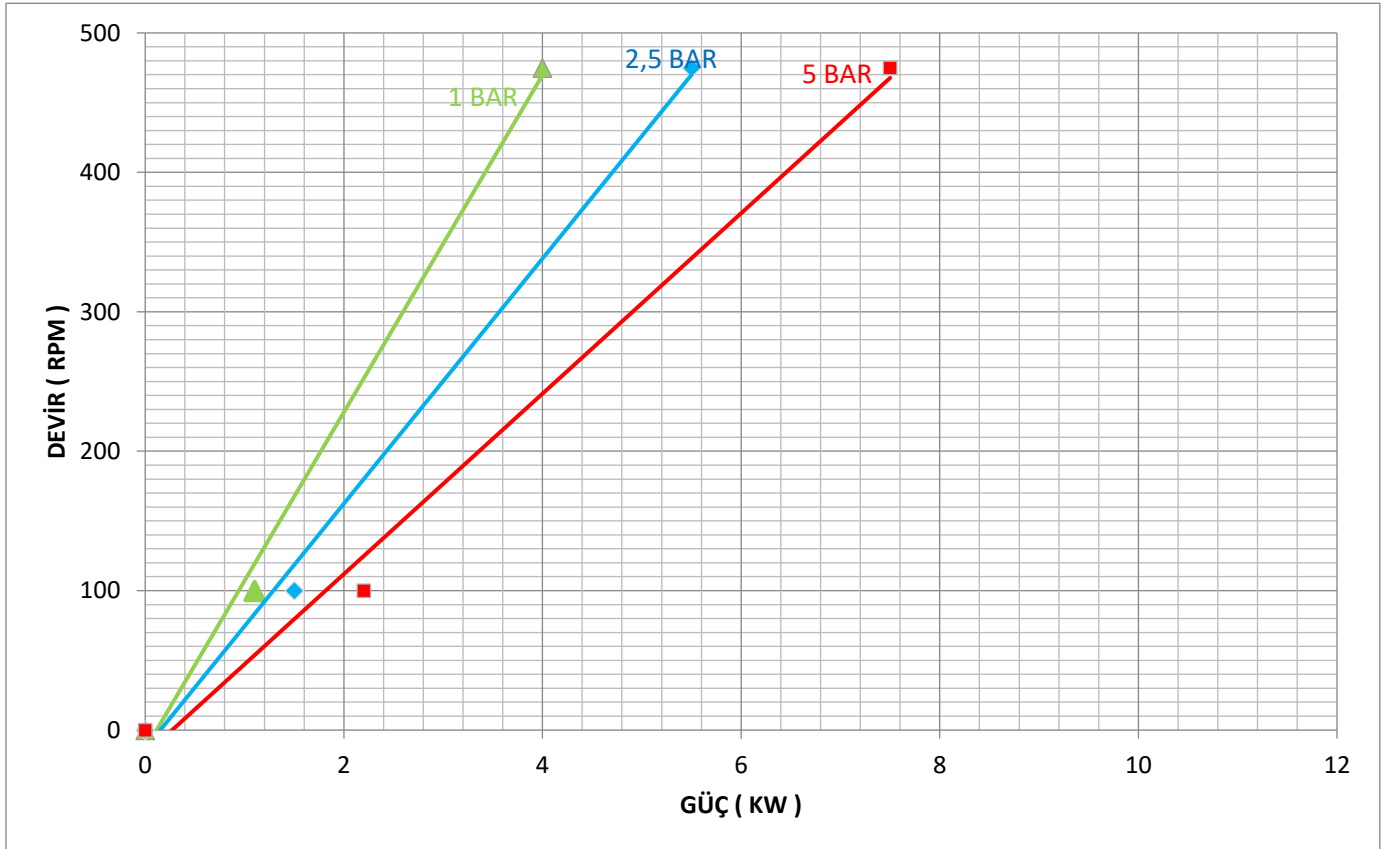

TESTLER SAE30 YAĞ İLE ODA SICAKLIĞINDA ( YAKLAŞIK 100 CST) YAPILMIŞTIR.

## KIP2½" İÇ DİŞLİ POMPA PERFORMANS EĞRİLERİ

### 1- Devir - Debi

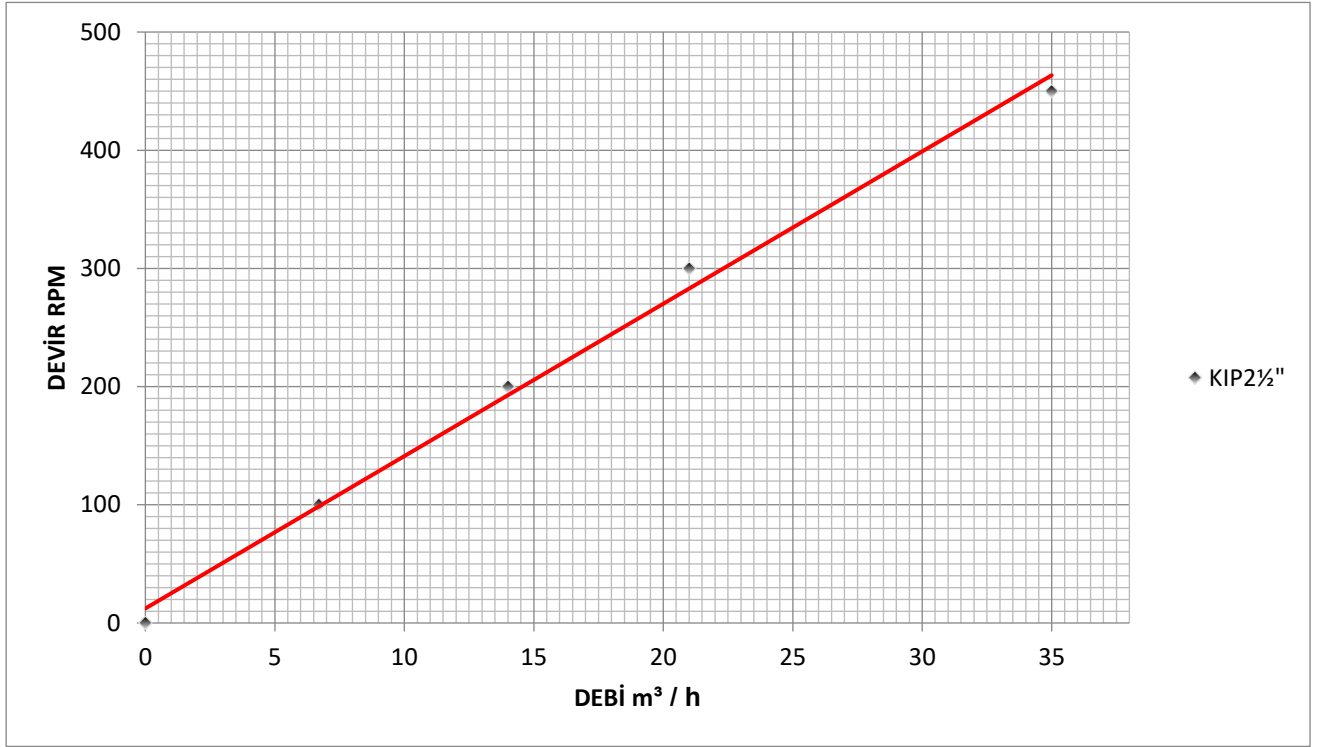

### 2- Devir - Güç - Basınç

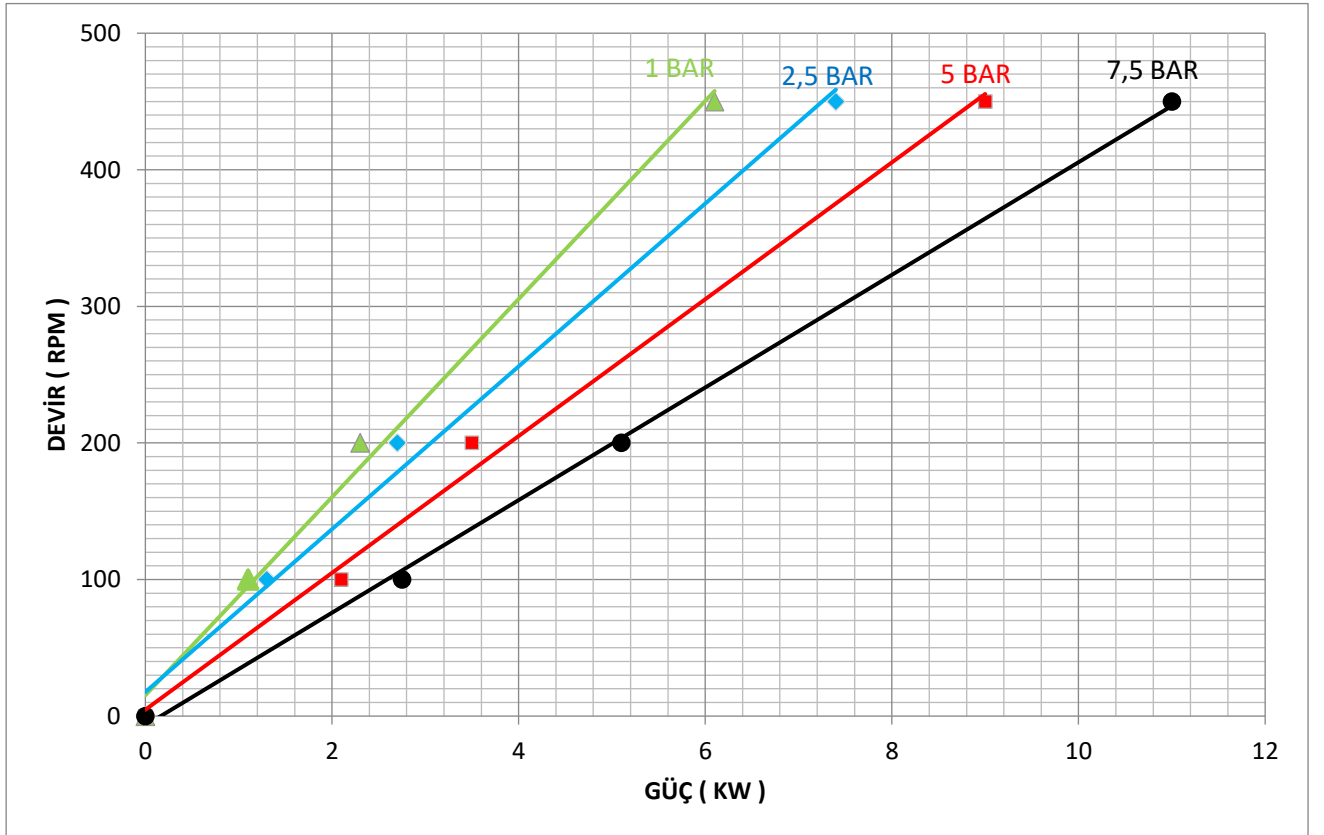

TESTLER SAE30 YAĞ İLE ODA SICAKLIĞINDA ( YAKLAŞIK 100 CST) YAPILMIŞTIR.

## KIP3" İÇ DİŞLİ POMPA PERFORMANS EĞRİLERİ

### 1- Devir - Debi

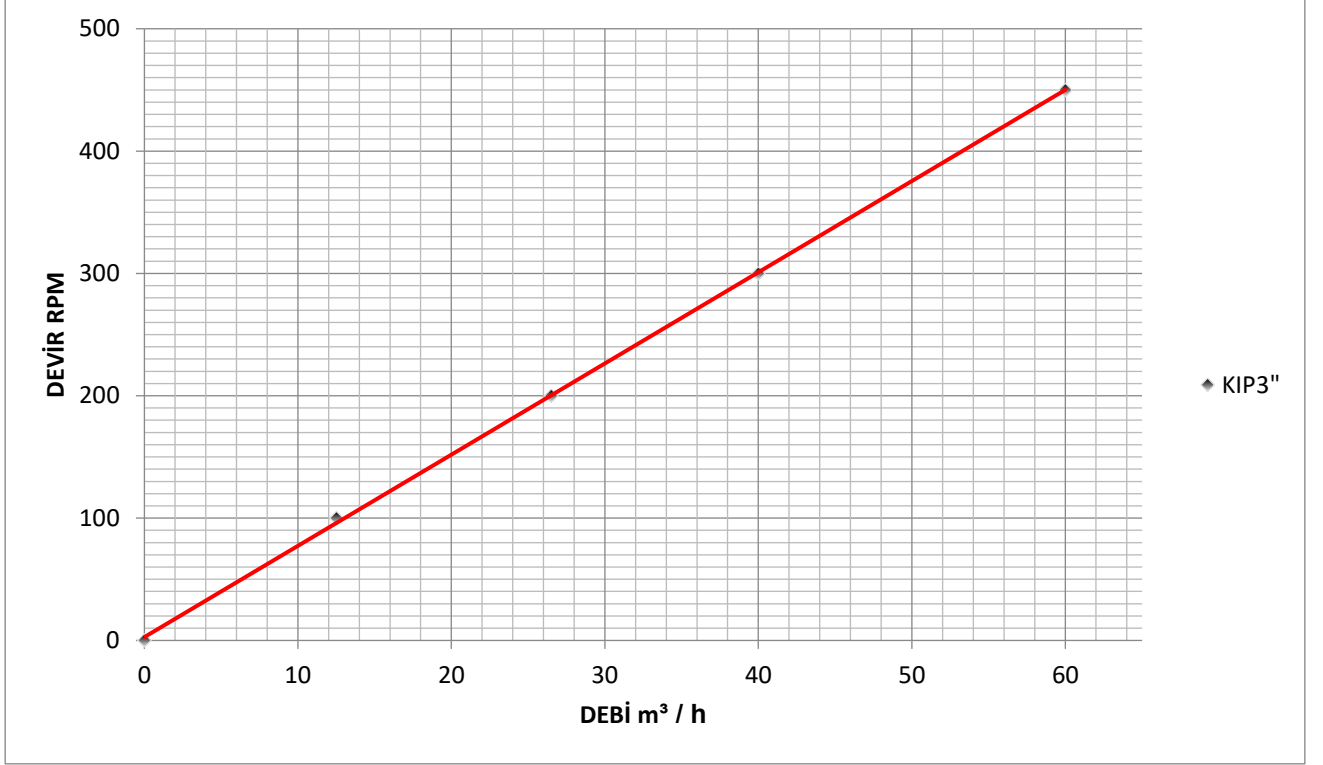

### 2- Devir - Güç - Basınç

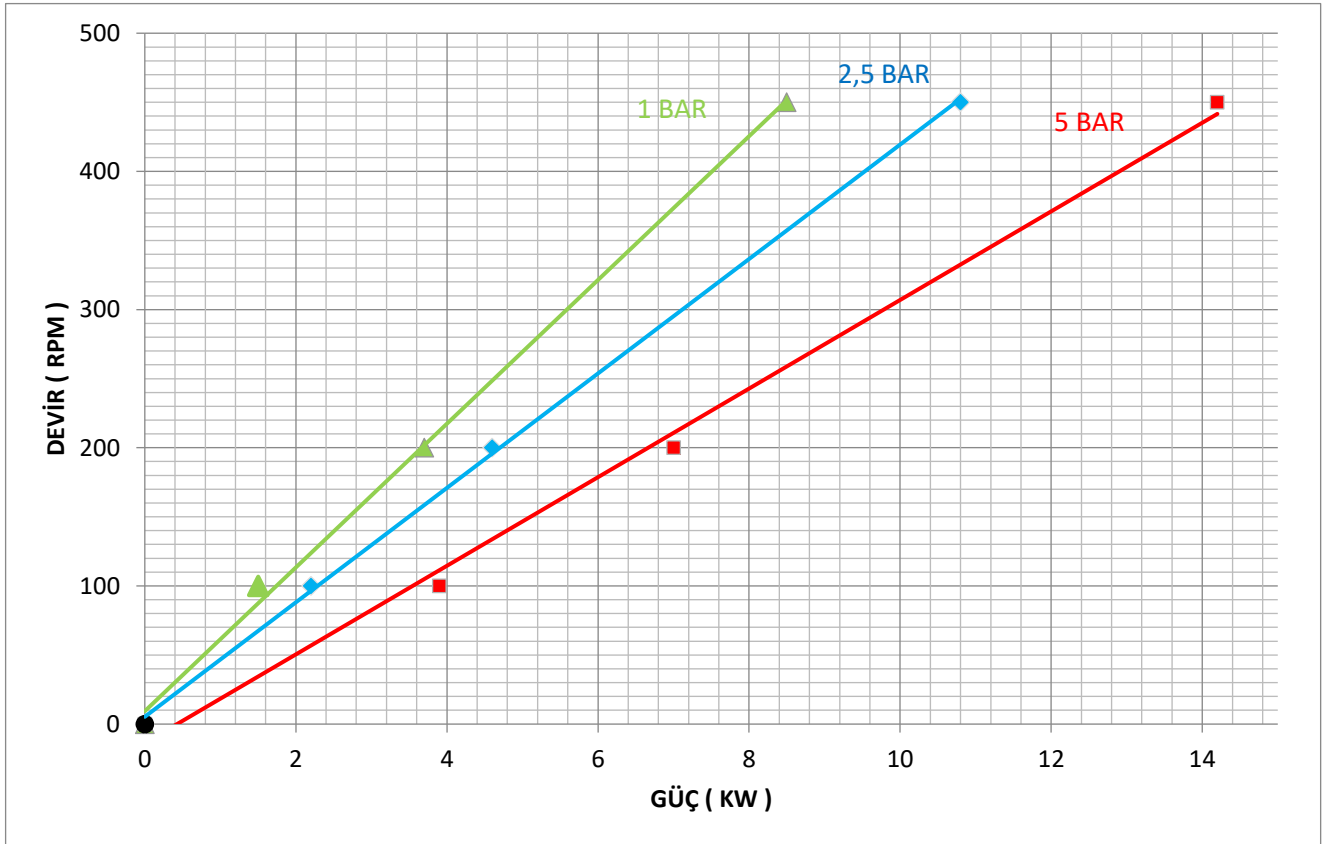

TESTLER SAE30 YAĞ İLE ODA SICAKLIĞINDA ( YAKLAŞIK 100 CST) YAPILMIŞTIR.

## KIP4" İÇ DİŞLİ POMPA PERFORMANS EĞRİLERİ

### 1- Devir - Debi

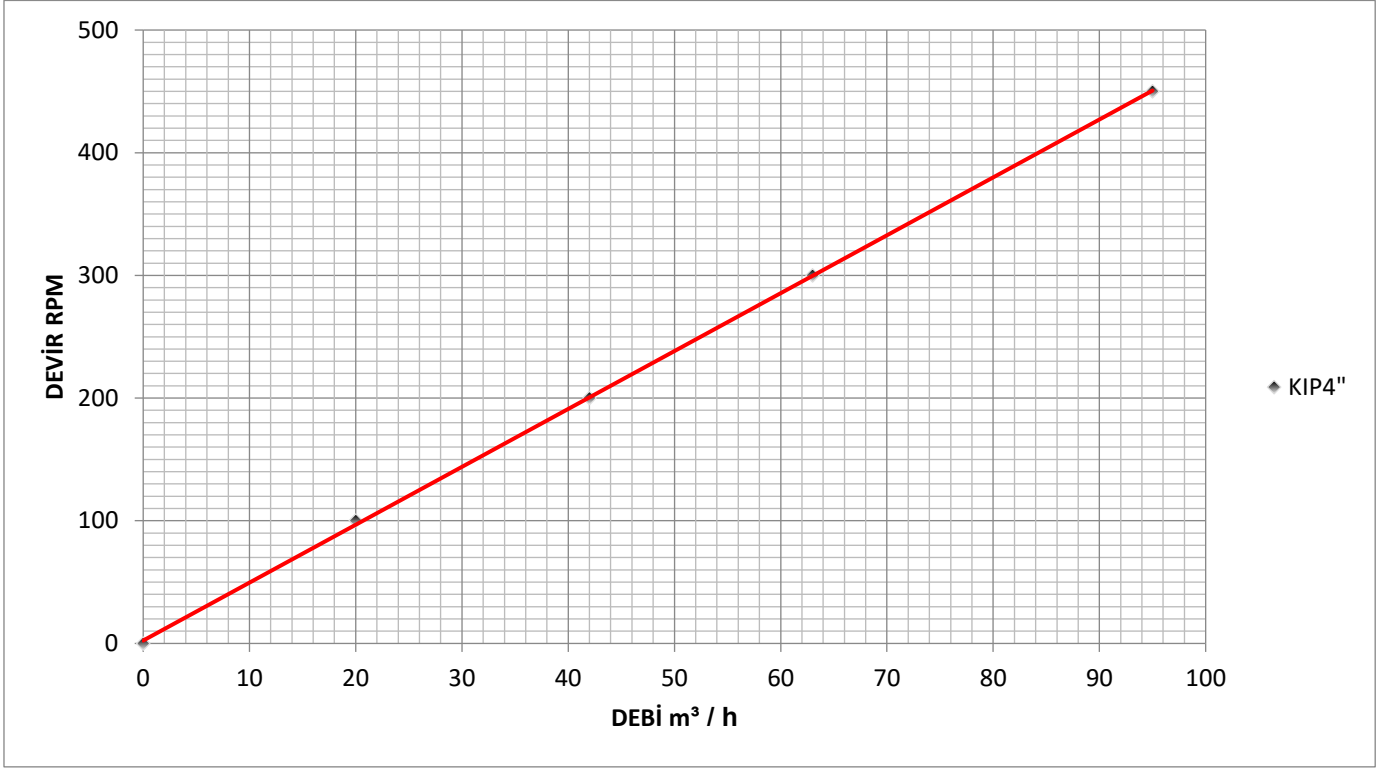

### 2- Devir - Güç - Basınç

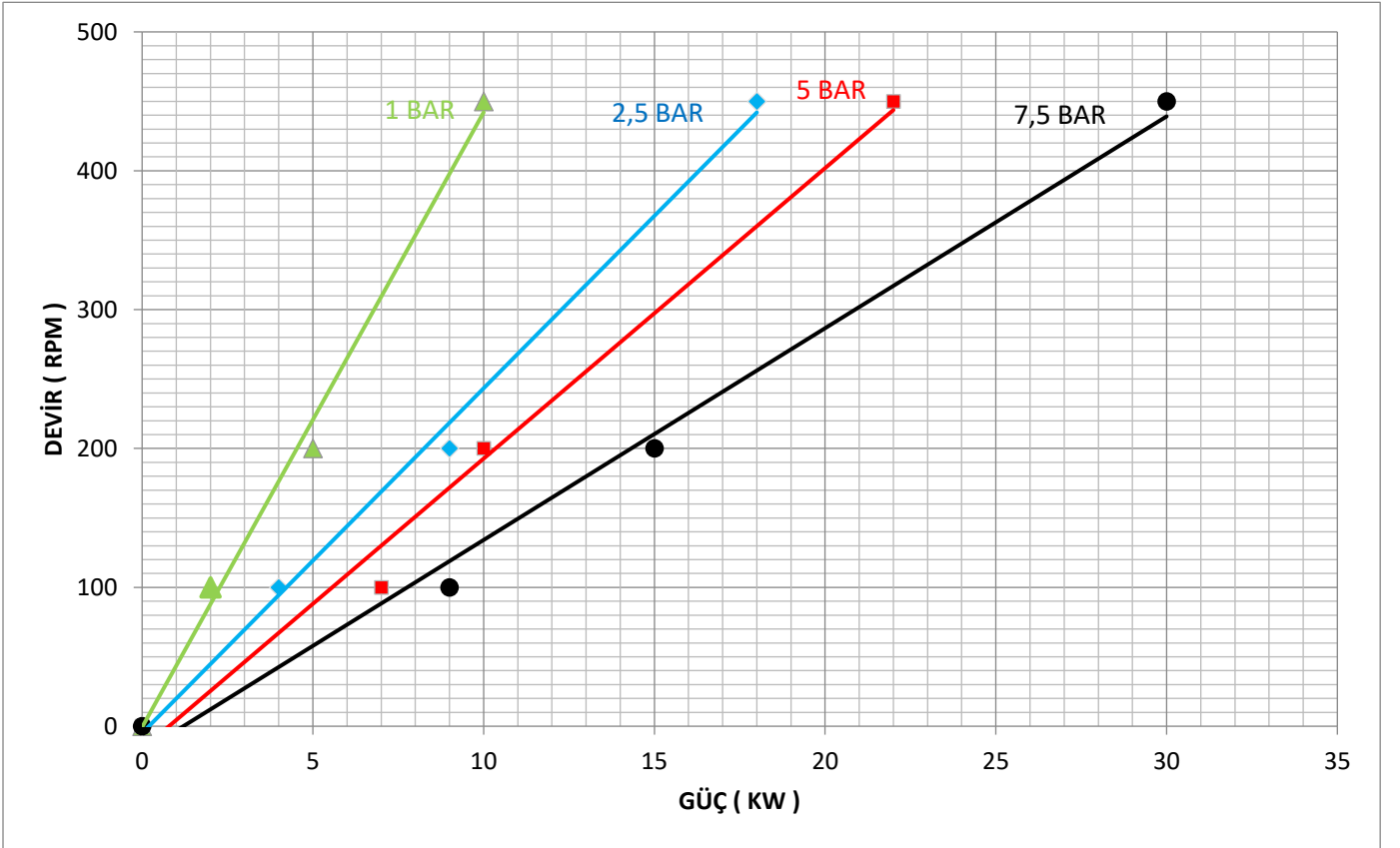

TESTLER SAE30 YAĞ İLE ODA SICAKLIĞINDA ( YAKLAŞIK 100 CST) YAPILMIŞTIR.

## KIP6" İÇ DİŞLİ POMPA PERFORMANS EĞRİLERİ

### 1- Devir - Debi

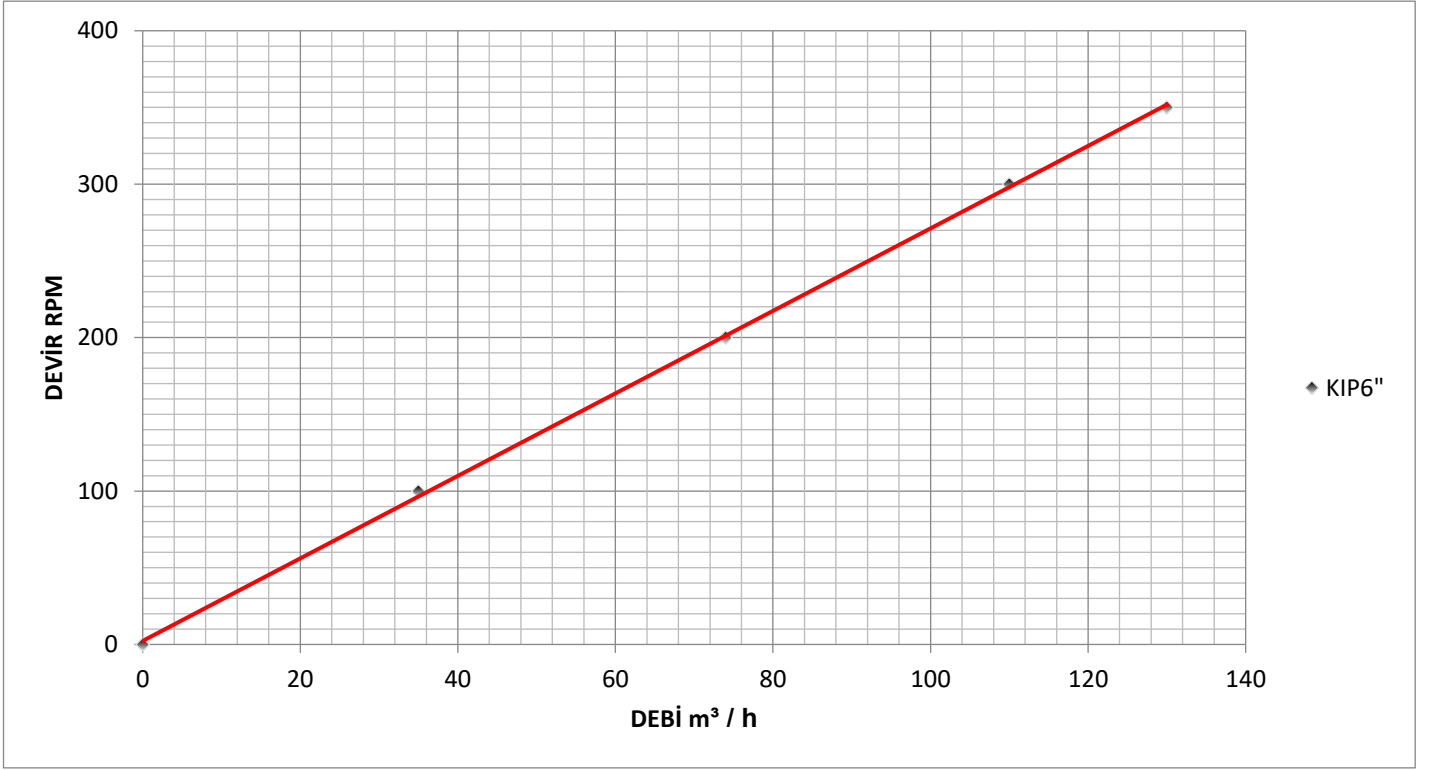

### 2- Devir - Güç - Basınç

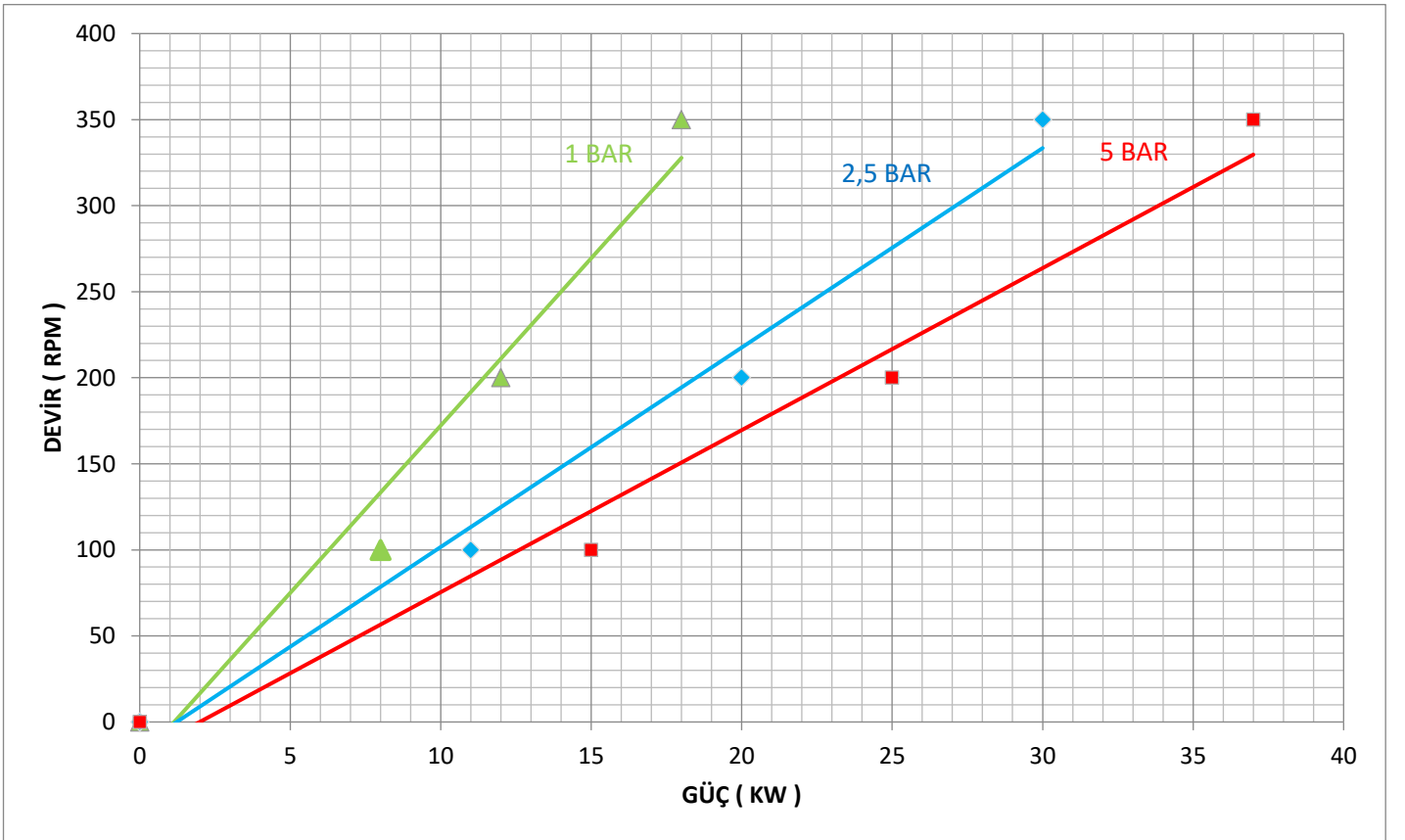

TESTLER SAE30 YAĞ İLE ODA SICAKLIĞINDA ( YAKLAŞIK 100 CST) YAPILMIŞTIR.



## KHP½" HELİS DİŞLİ PERFORMANS EĞRİLERİ

### 1- Devir - Debi

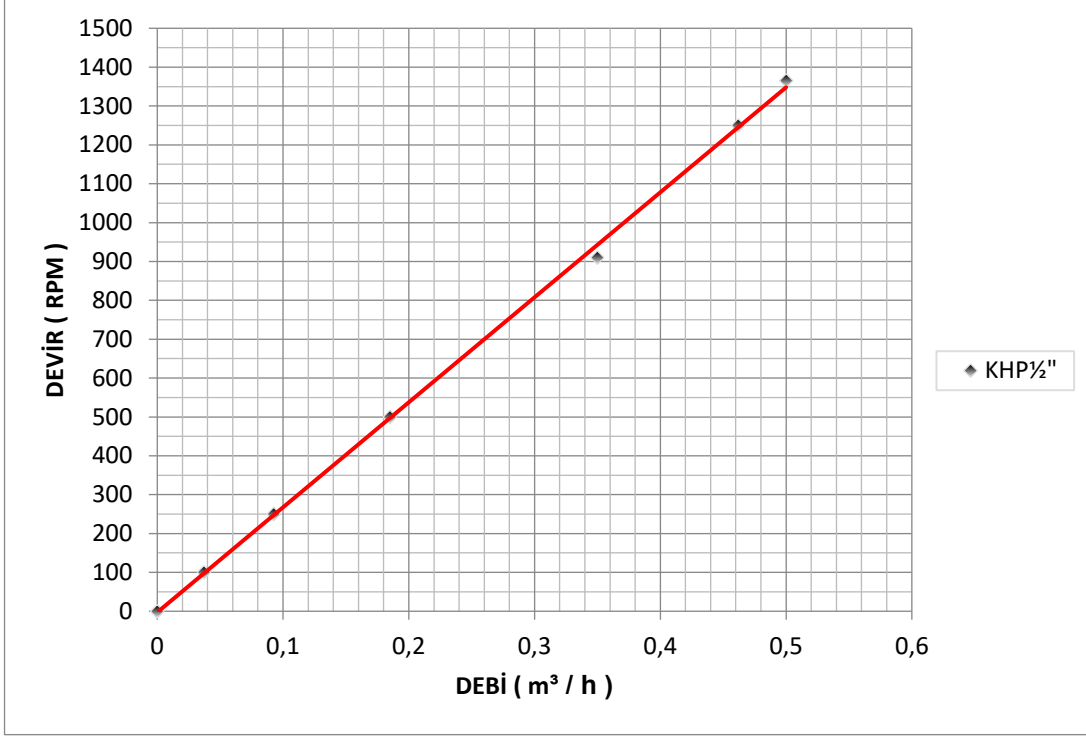

### 2- Devir - Güç - Basınç

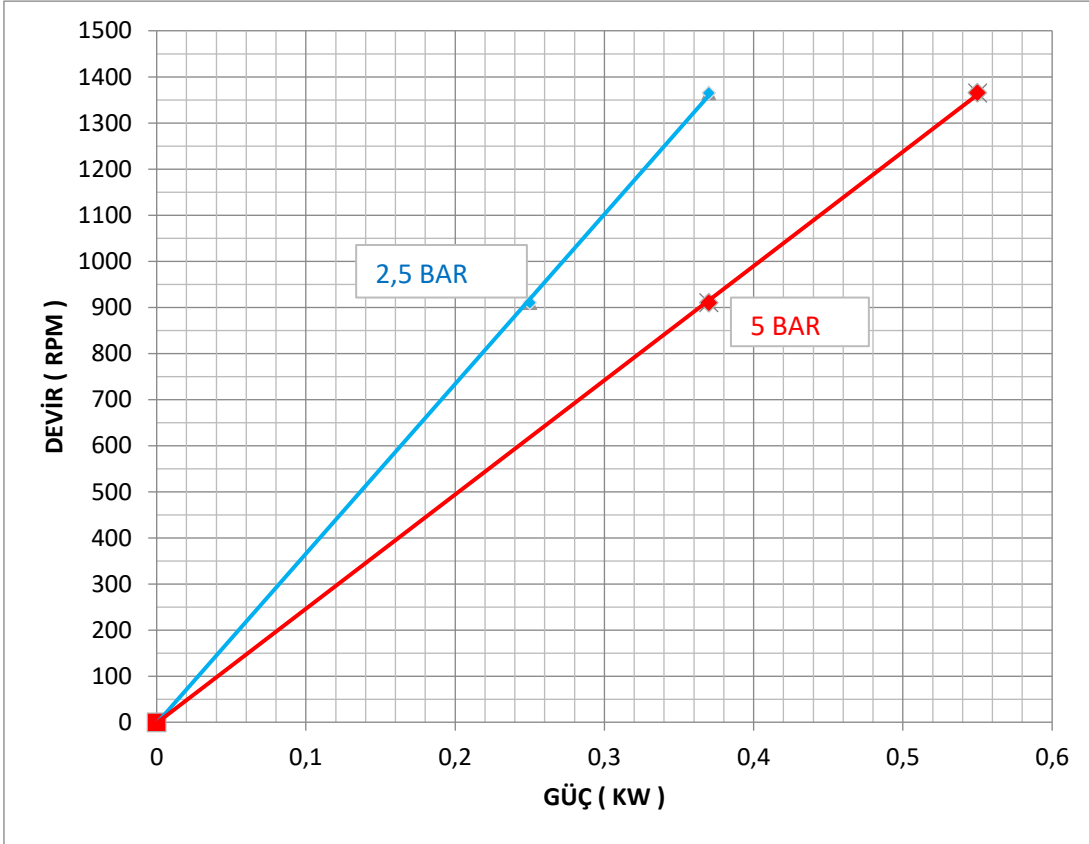

TESTLER SAE30 YAĞ İLE ODA SICAKLIĞINDA (YAKLAŞIK 100 CST) YAPILMIŞTIR.

## KHP¾" HELİS DİŞLİ PERFORMANS EĞRİLERİ

### 1- Devir - Debi

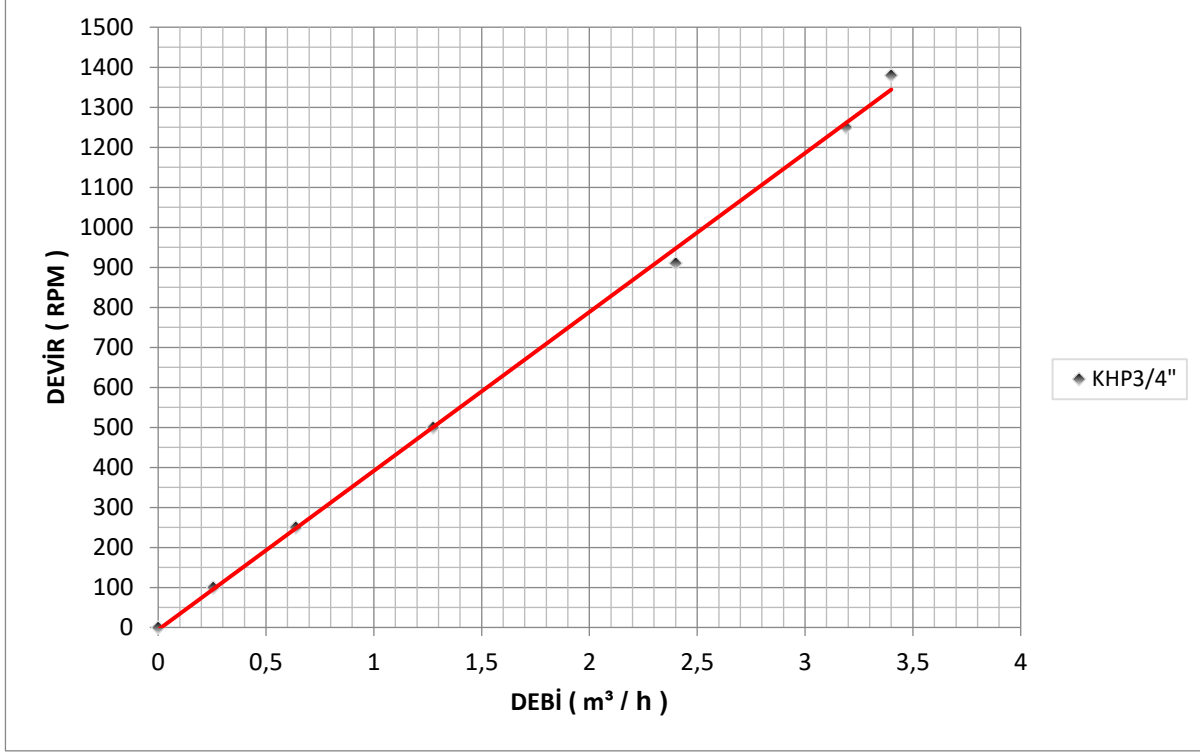

### 2- Devir - Güç - Basınç

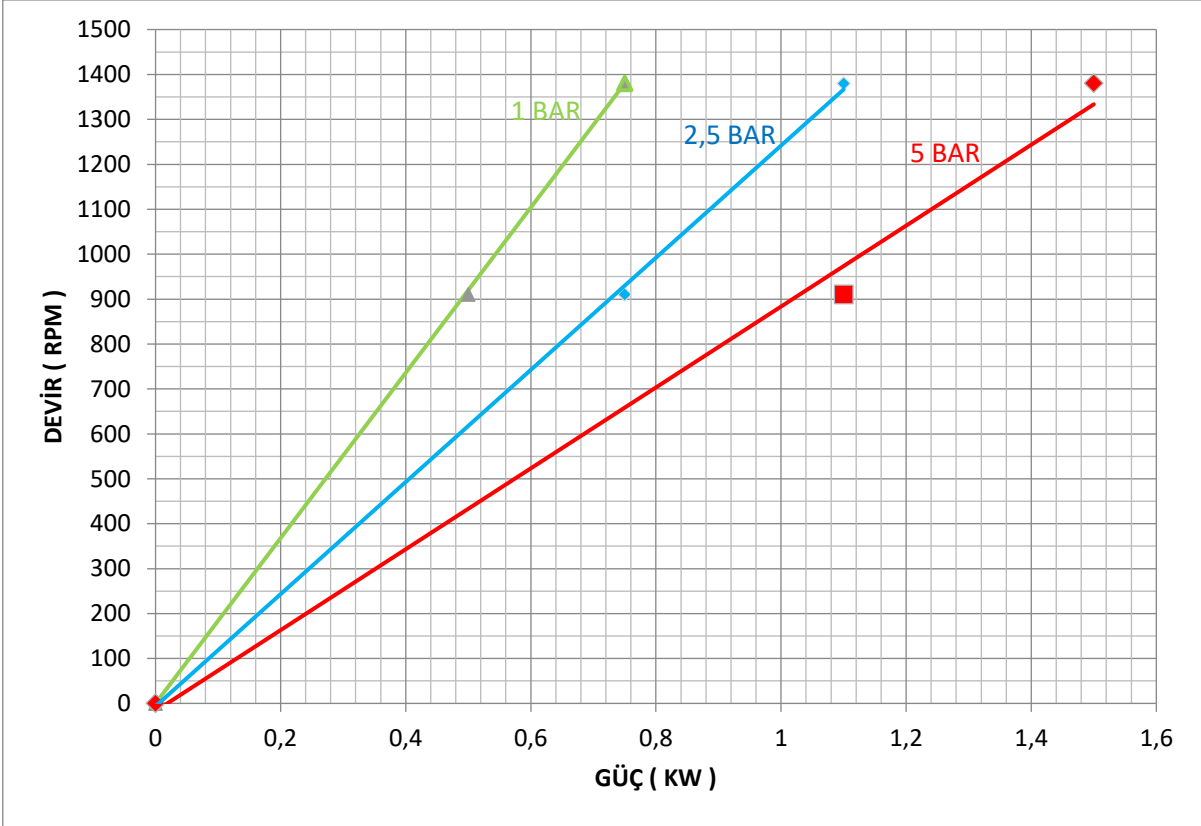

TESTLER SAE30 YAĞ İLE ODA SICAKLIĞINDA (YAKLAŞIK 100 CST) YAPILMIŞTIR.

## KHP1" HELİS DİŞLİ PERFORMANS EĞRİLERİ

### 1- Devir - Debi

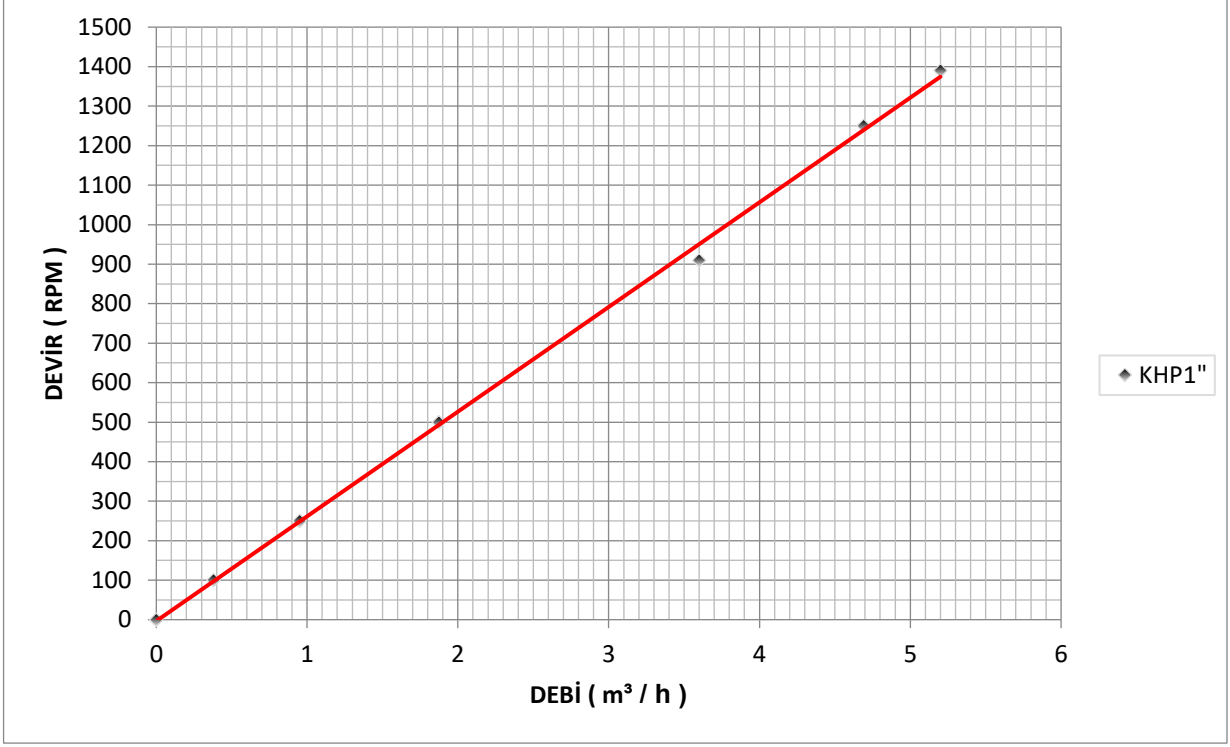

### 2- Devir - Güç - Basınç

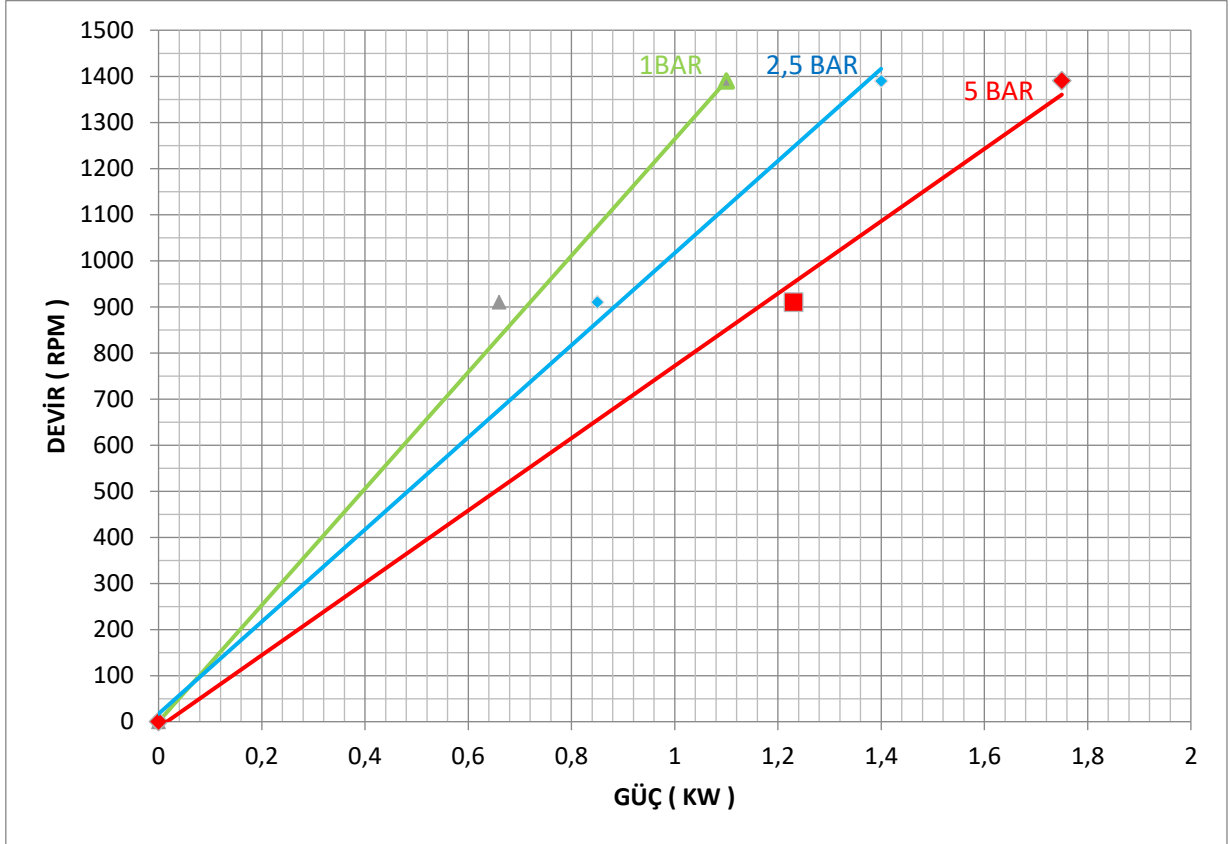

TESTLER SAE30 YAĞ İLE ODA SICAKLIĞINDA (YAKLAŞIK 100 CST) YAPILMIŞTIR.

## KHP1½" HELİS DİŞLİ PERFORMANS EĞRİLERİ

### 1- Devir - Debi

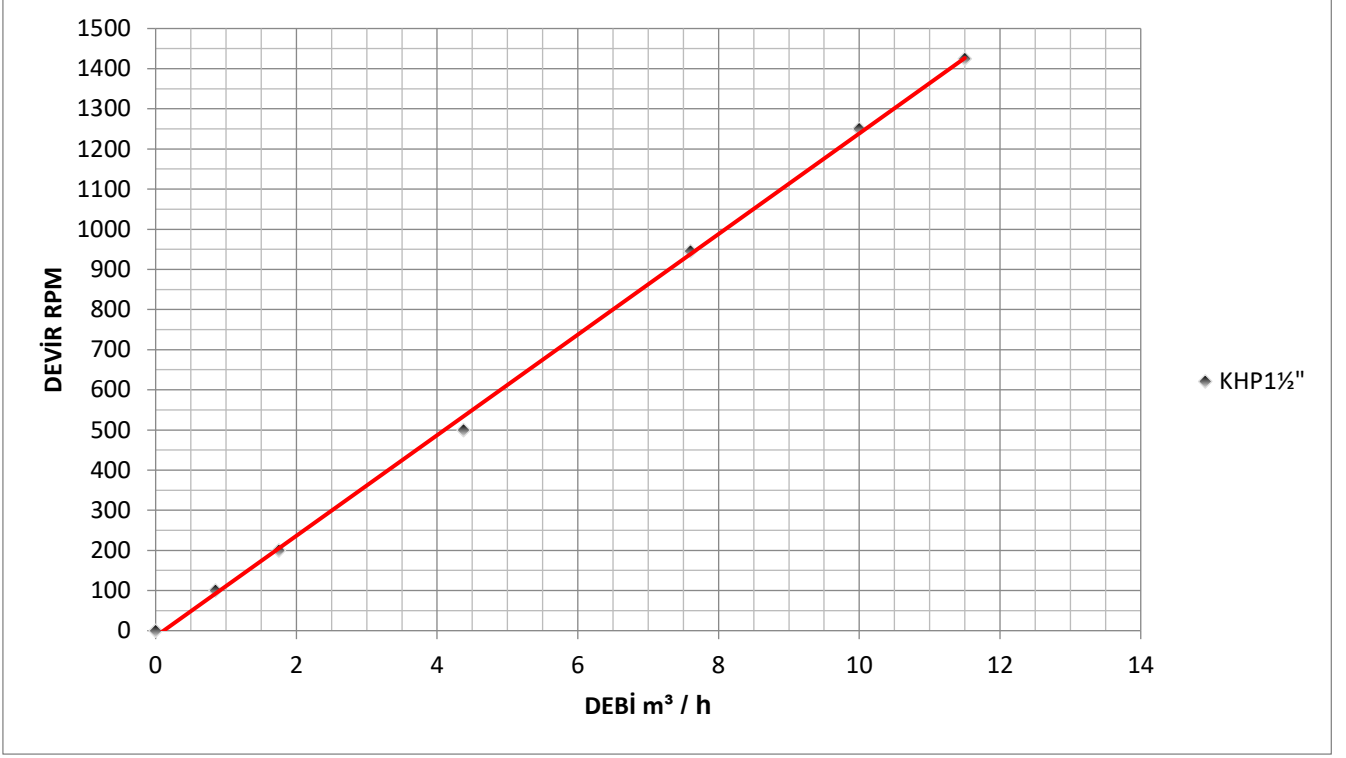

### 2- Devir - Güç - Basınç

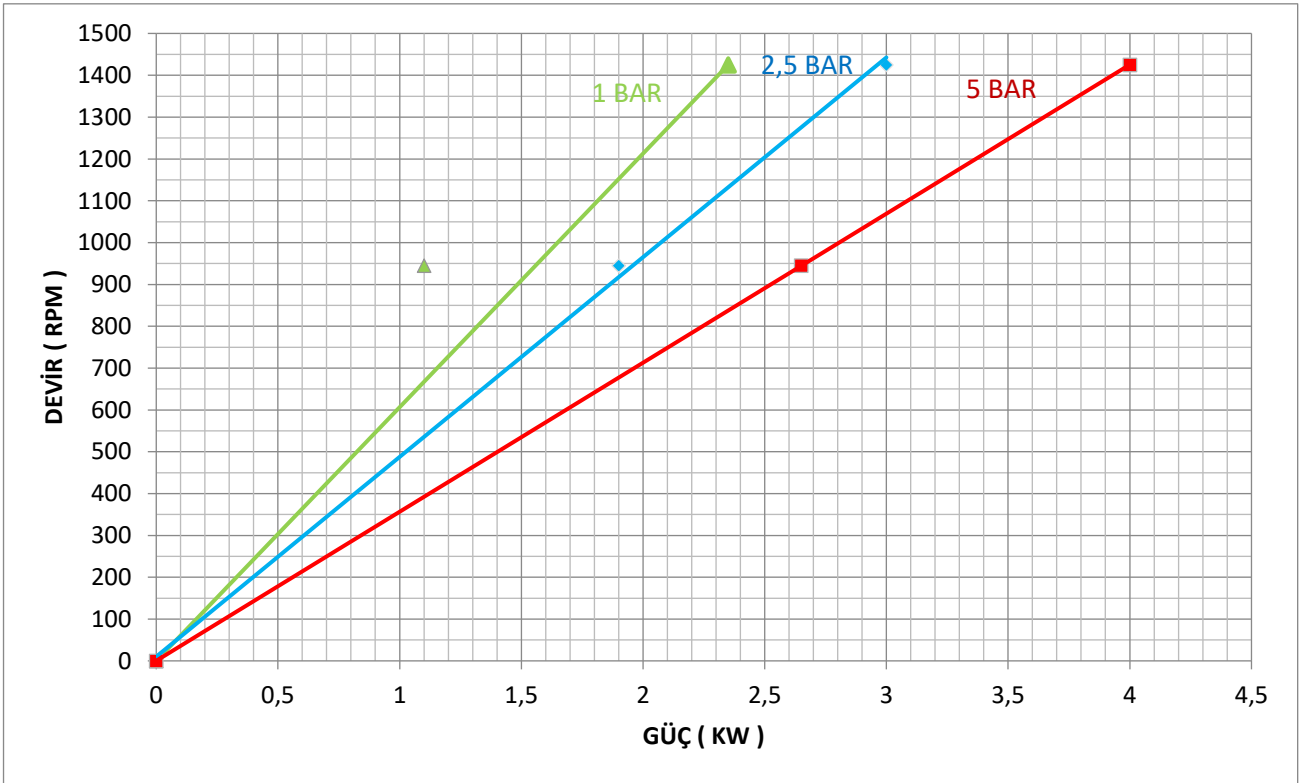

TESTLER SAE30 YAĞ İLE ODA SICAKLIĞINDA ( YAKLAŞIK 100 CST) YAPILMIŞTIR.

## KHP2" HELİS DİŞLİ PERFORMANS EĞRİLERİ

### 1- Devir - Debi

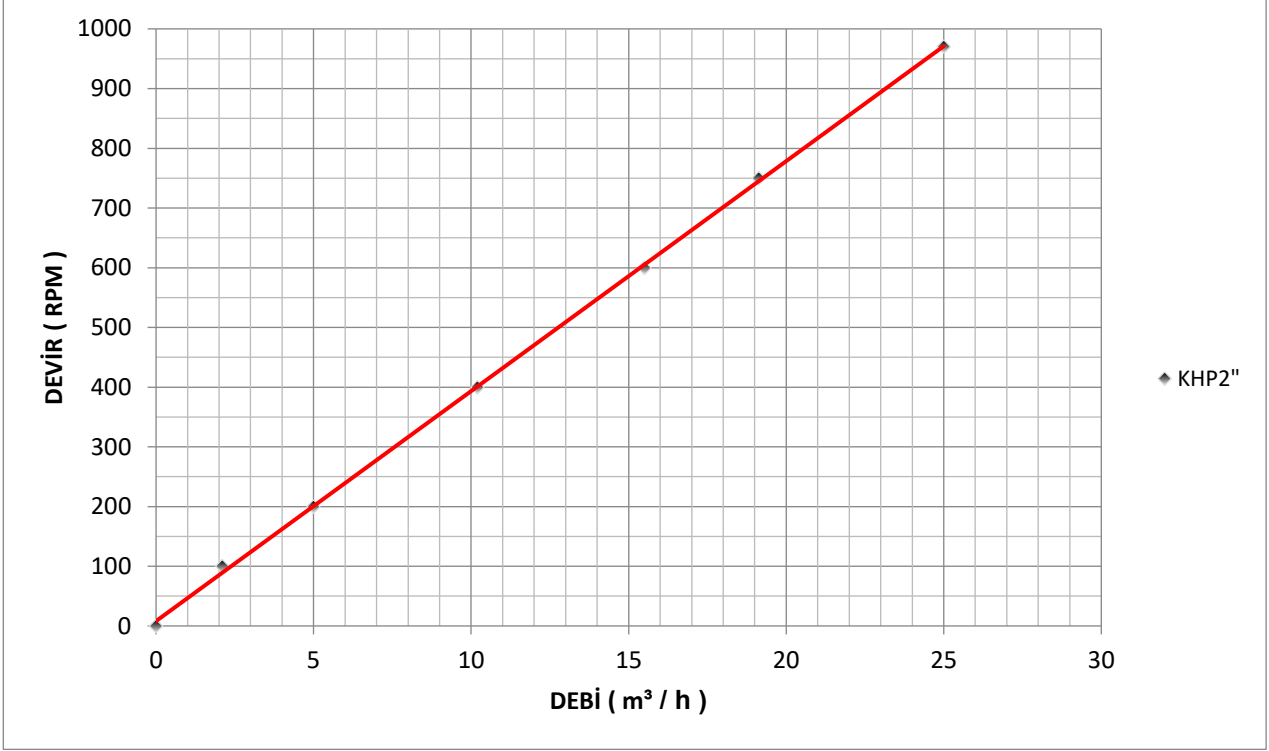

### 2- Devir - Güç - Basınç

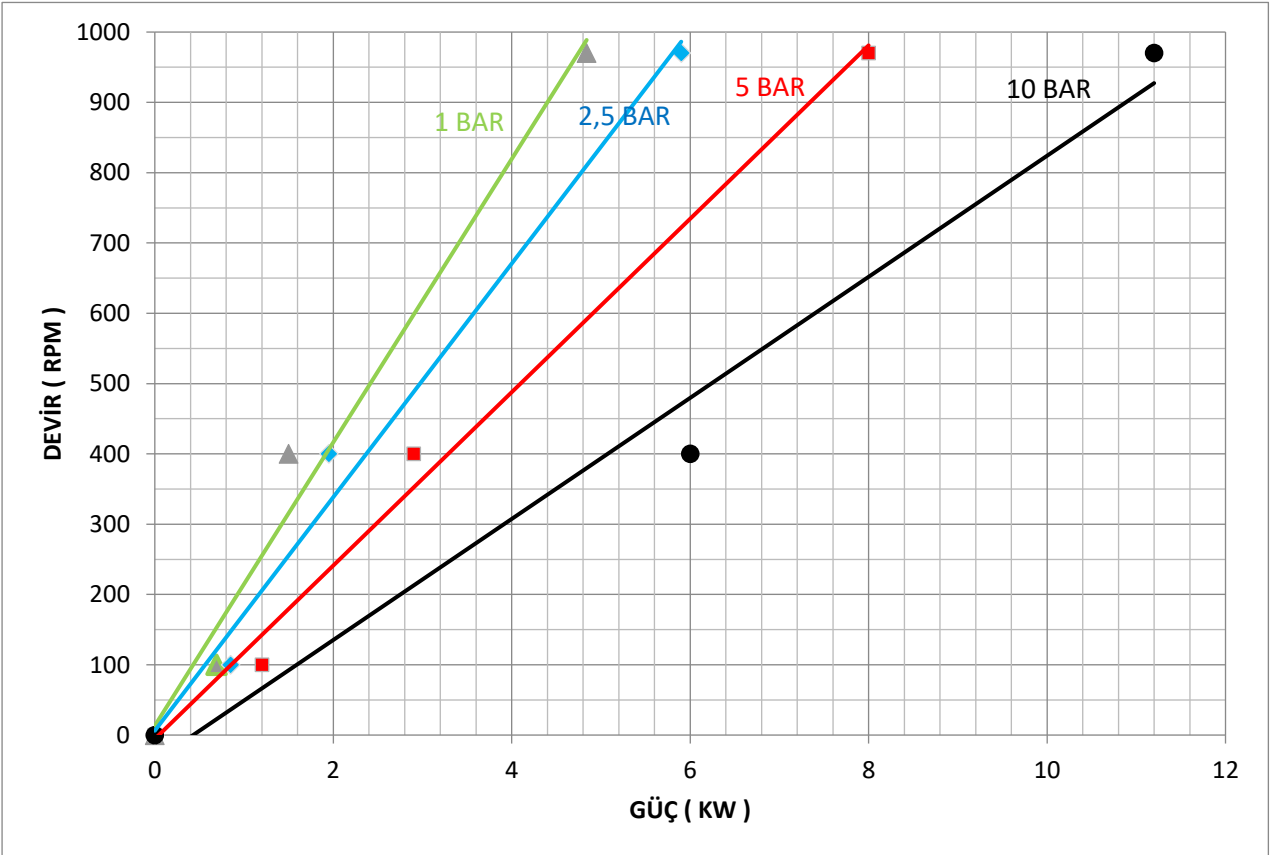

TESTLER SAE30 YAĞ İLE ODA SICAKLIĞINDA (YAKLAŞIK 100 CST) YAPILMIŞTIR.

## KHP2½" HELİS DİŞLİ PERFORMANS EĞRİLERİ

### 1- Devir - Debi

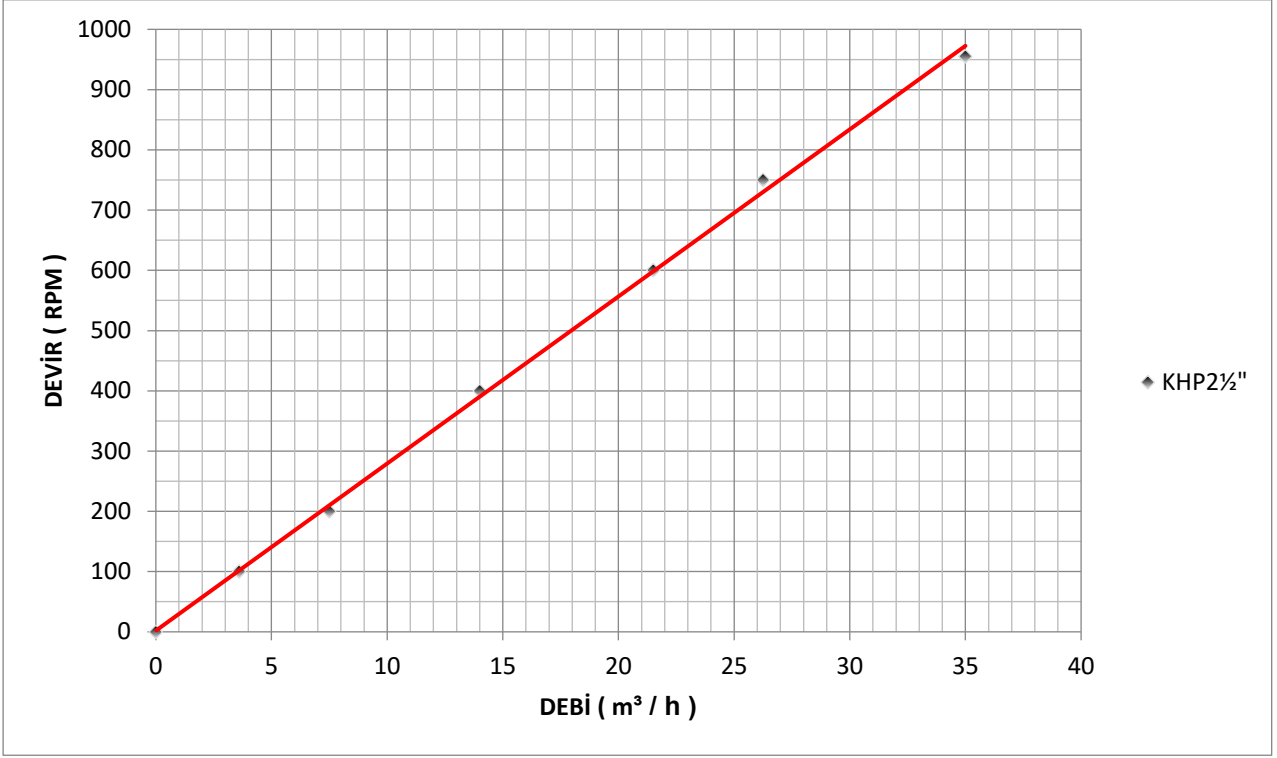

### 2- Devir - Güç - Basınç

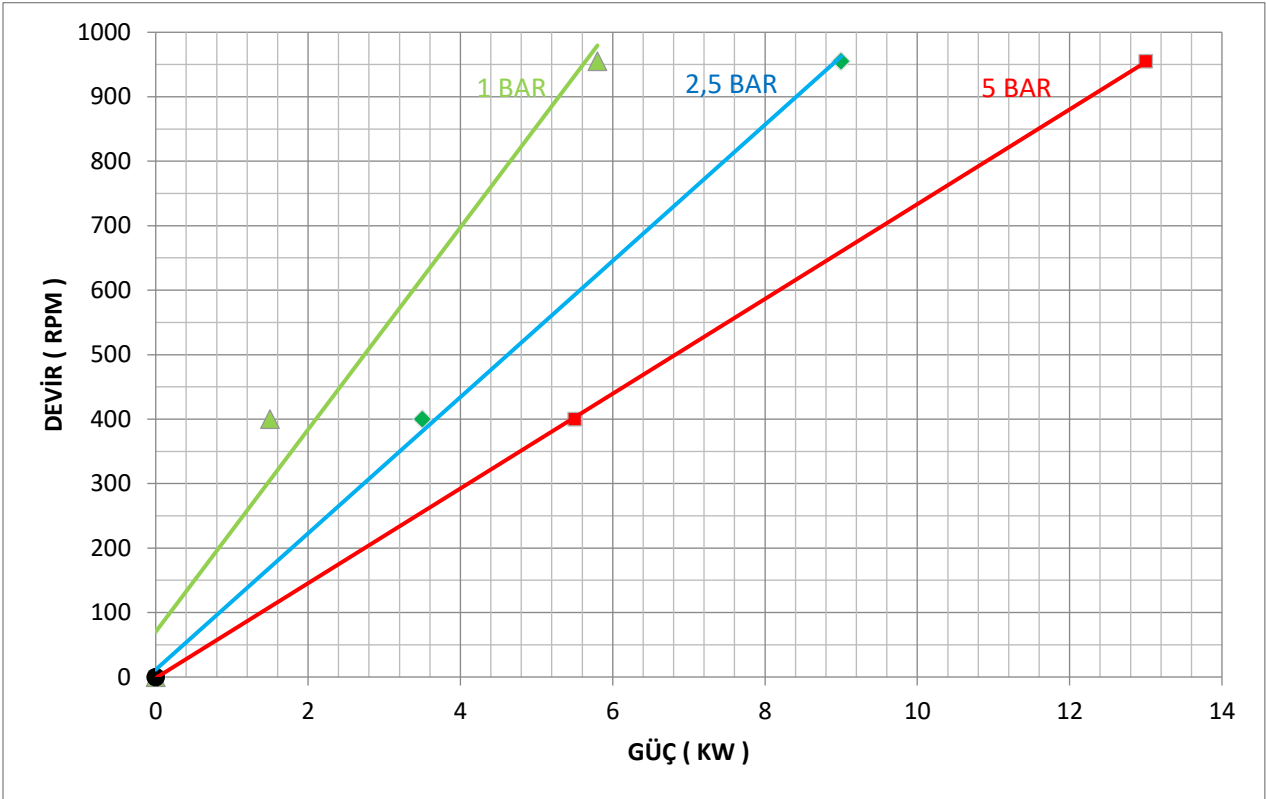

TESTLER SAE30 YAĞ İLE ODA SICAKLIĞINDA (YAKLAŞIK 100 CST) YAPILMIŞTIR.

## KHP3" HELİS DİŞLİ PERFORMANS EĞRİLERİ

### 1- Devir - Debi

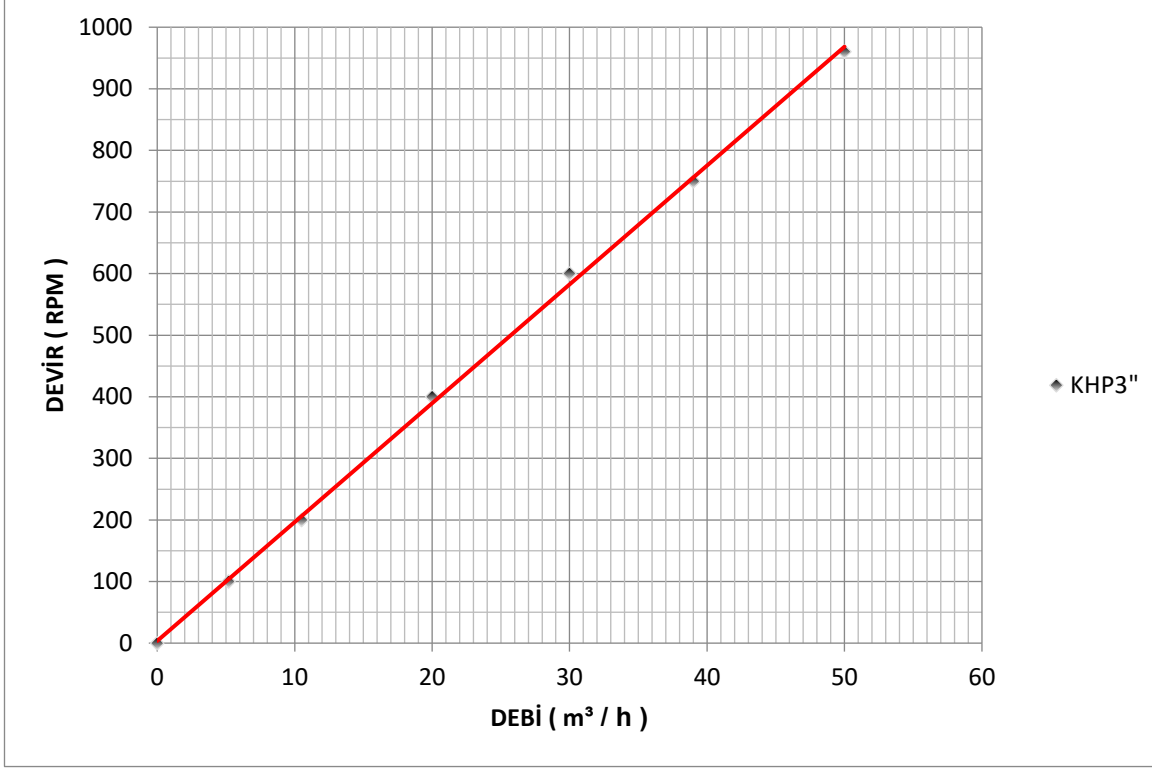

### 2- Devir - Güç - Basınç

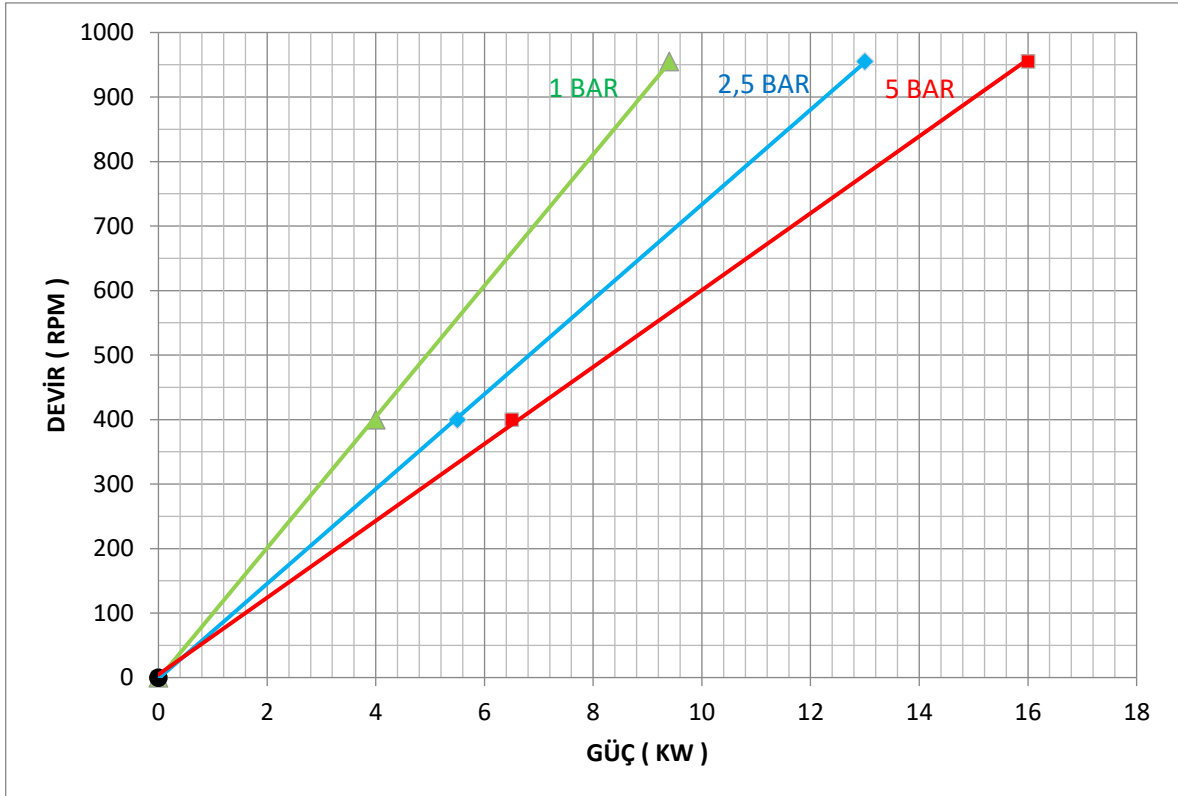

TESTLER SAE30 YAĞ İLE ODA SICAKLIĞINDA (YAKLAŞIK 100 CST) YAPILMIŞTIR.

## KHP4" HELİS DİŞLİ PERFORMANS EĞRİLERİ

### 1- Devir - Debi

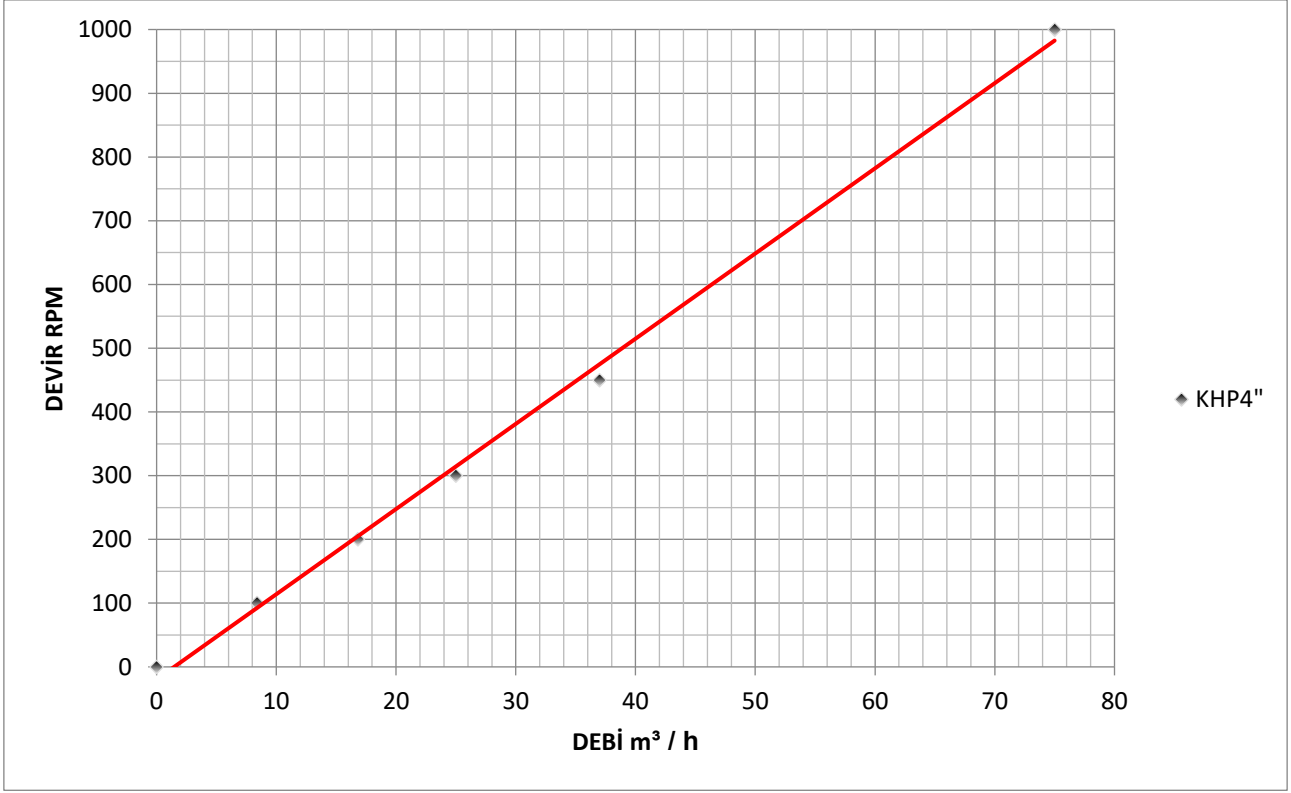

### 2- Devir - Güç - Basınç

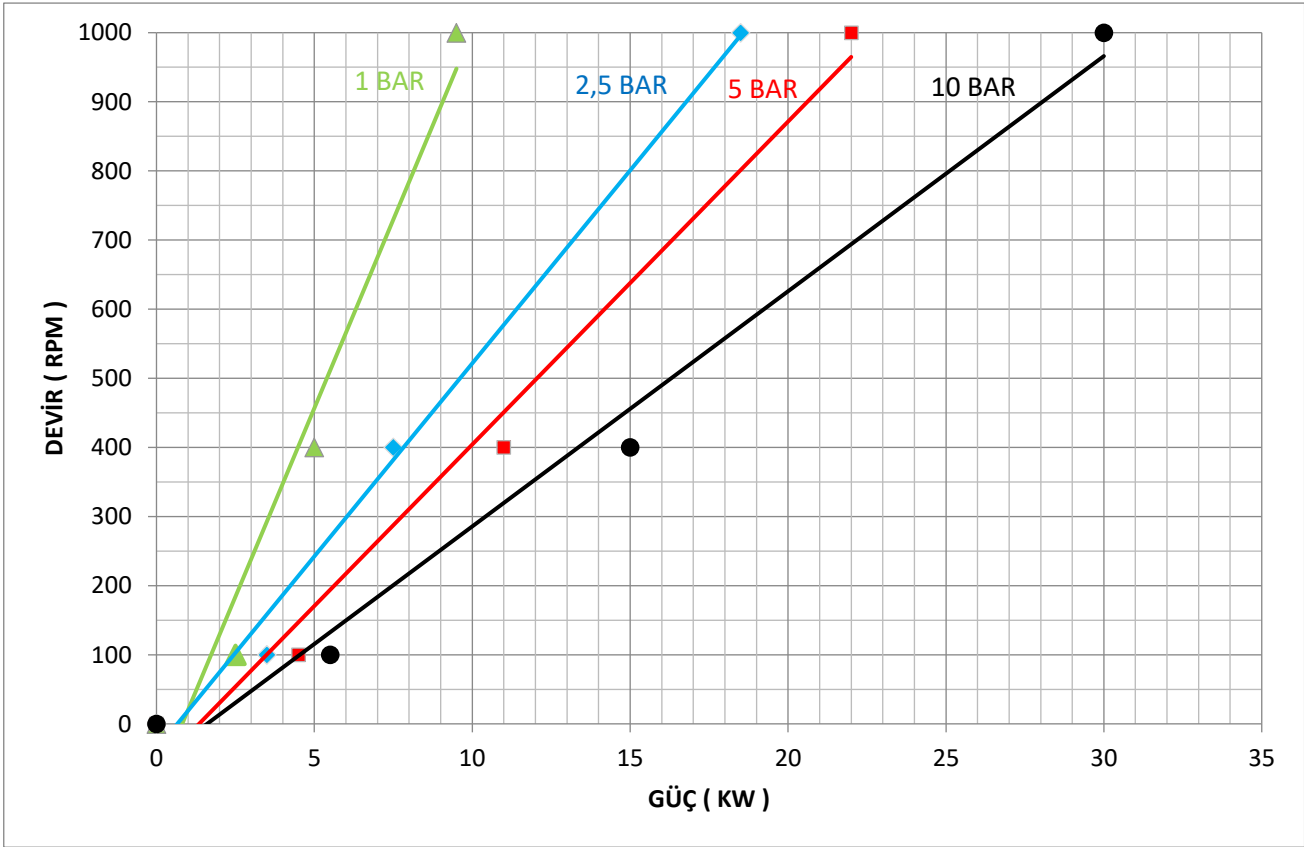

TESTLER SAE30 YAĞ İLE ODA SICAKLIĞINDA ( YAKLAŞIK 100 CST) YAPILMIŞTIR.



## KHP6" HELİS DİŞLİ PERFORMANS EĞRİLERİ

### 1- Devir - Debi

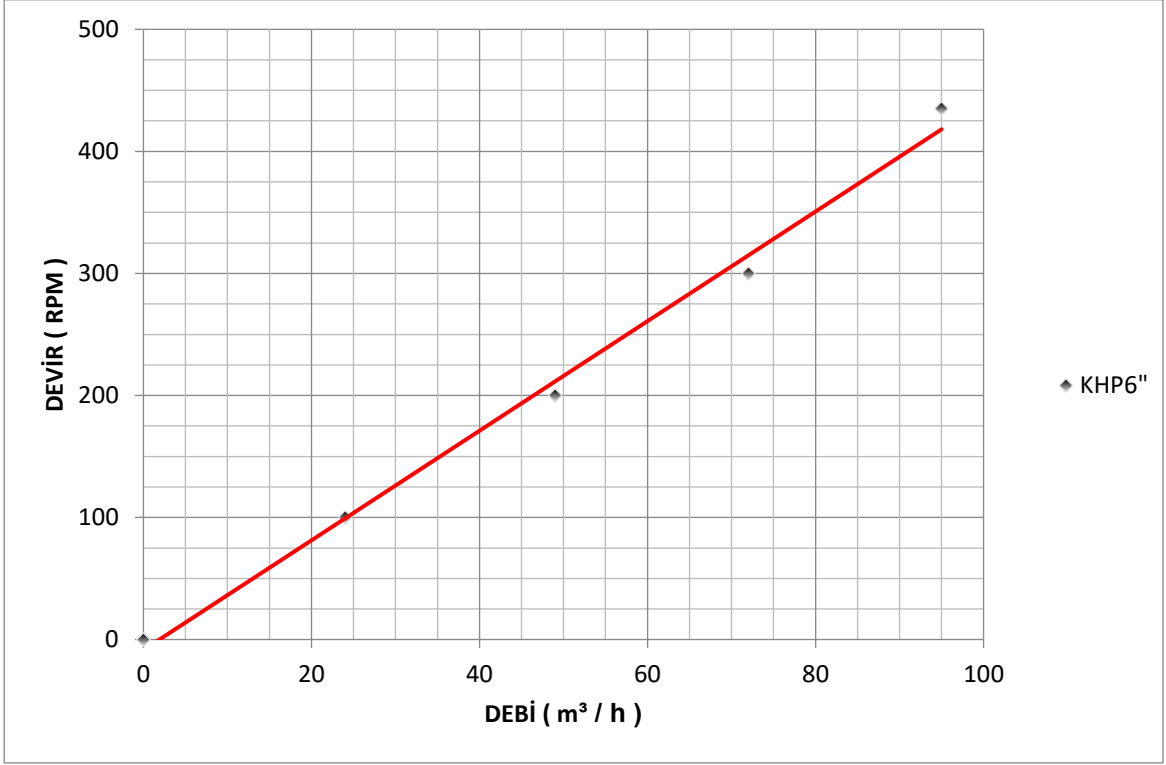

### 2- Devir - Güç - Basınç

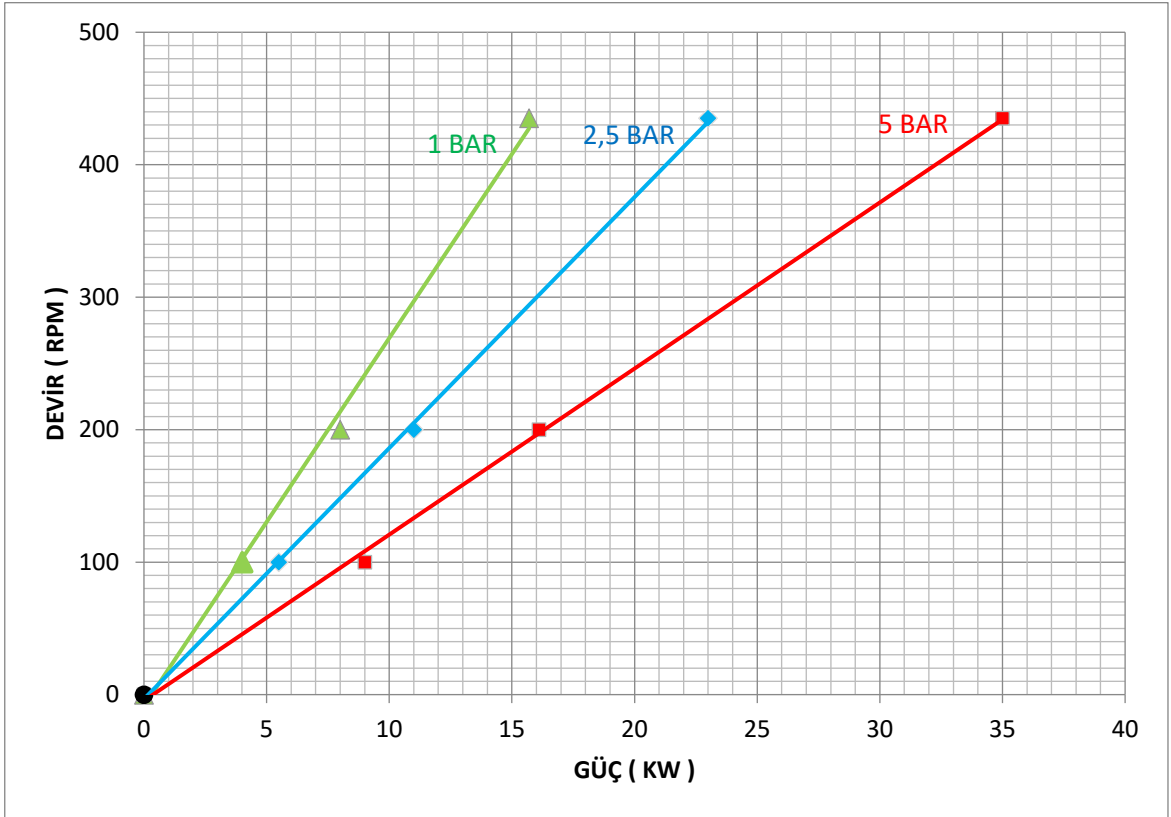

TESTLER SAE30 YAĞ İLE ODA SICAKLIĞINDA (YAKLAŞIK 100 CST) YAPILMIŞTIR.

## KLP1½" LOBLU POMPA PERFORMANS EĞRİLERİ

### 1- Devir-Debi



### 2- Devir - Güç - Basınç

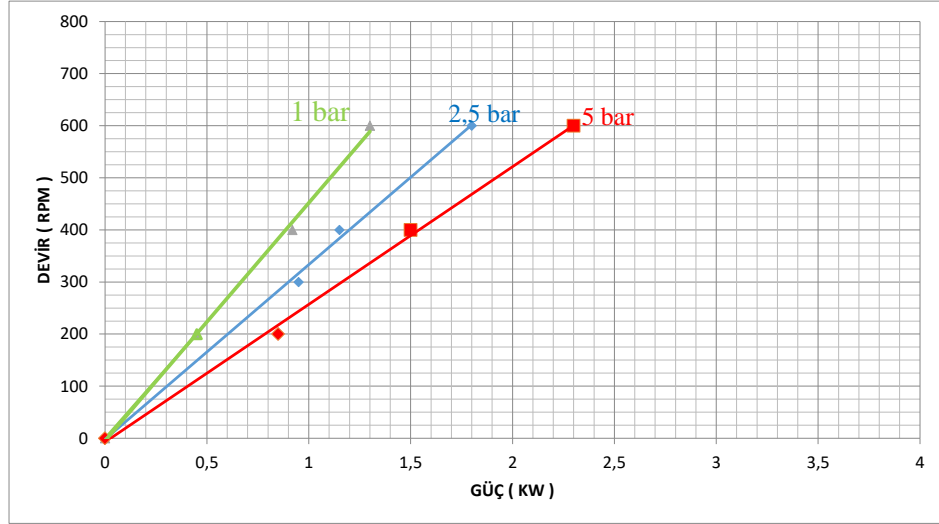

TESTLER SAE30 YAĞ İLE ODA SICAKLIĞINDA ( YAKLAŞIK 100 CST) YAPILMIŞTIR.

## KLP2" LOBLU POMPA PERFORMANS EĞRİLERİ

### 1- Devir-Debi

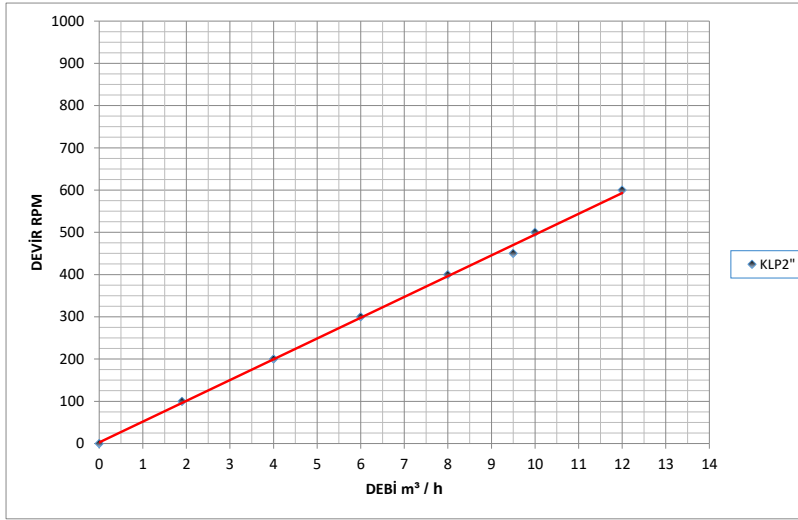

### 2- Devir - Güç - Basınç

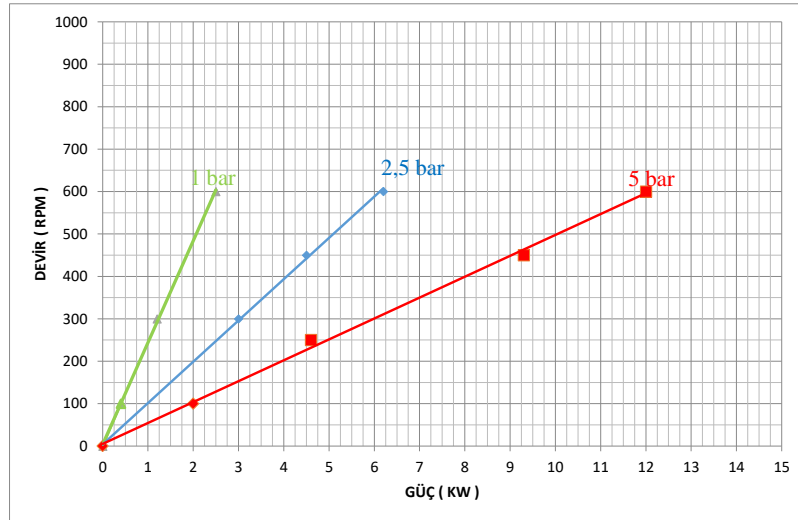

TESTLER SAE30 YAĞ İLE ODA SICAKLIĞINDA ( YAKLAŞIK 100 CST) YAPILMIŞTIR.

## KLP2½" LOBLU POMPA PERFORMANS EĞRİLERİ

### 1- Devir-Debi

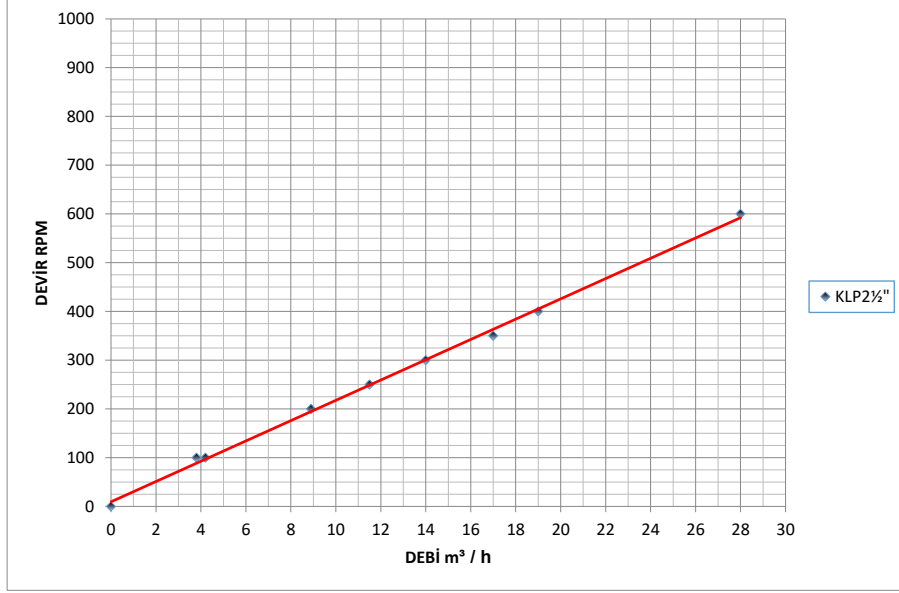

### 2- Devir - Güç - Basınç

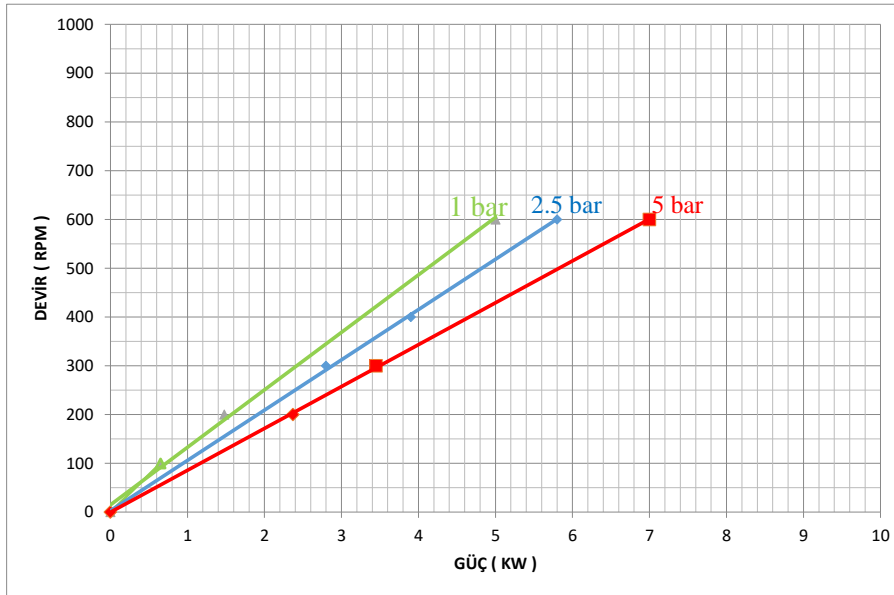

TESTLER SAE30 YAĞ İLE ODA SICAKLIĞINDA ( YAKLAŞIK 100 CST) YAPILMIŞTIR.

## KIP1" İÇ DİŞLİ POMPA PERFORMANS EĞRİLERİ

### 1- Devir - Debi

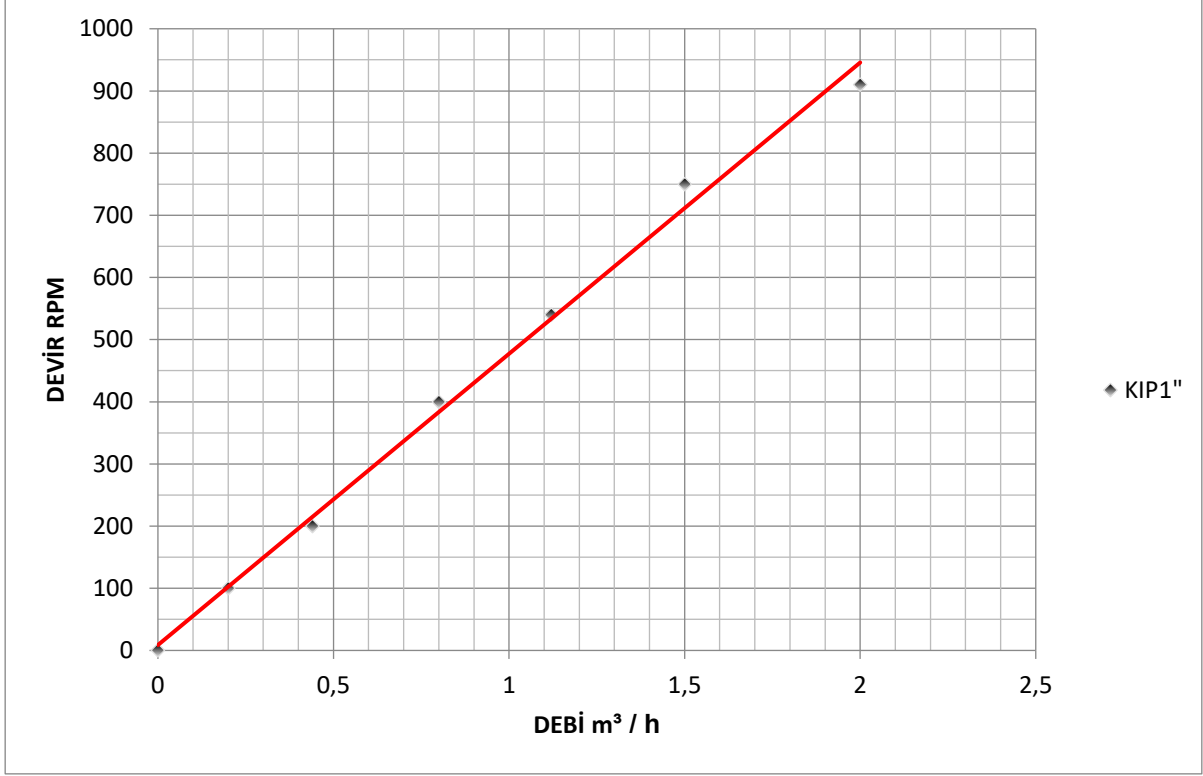

### 2- Devir - Güç - Basınç

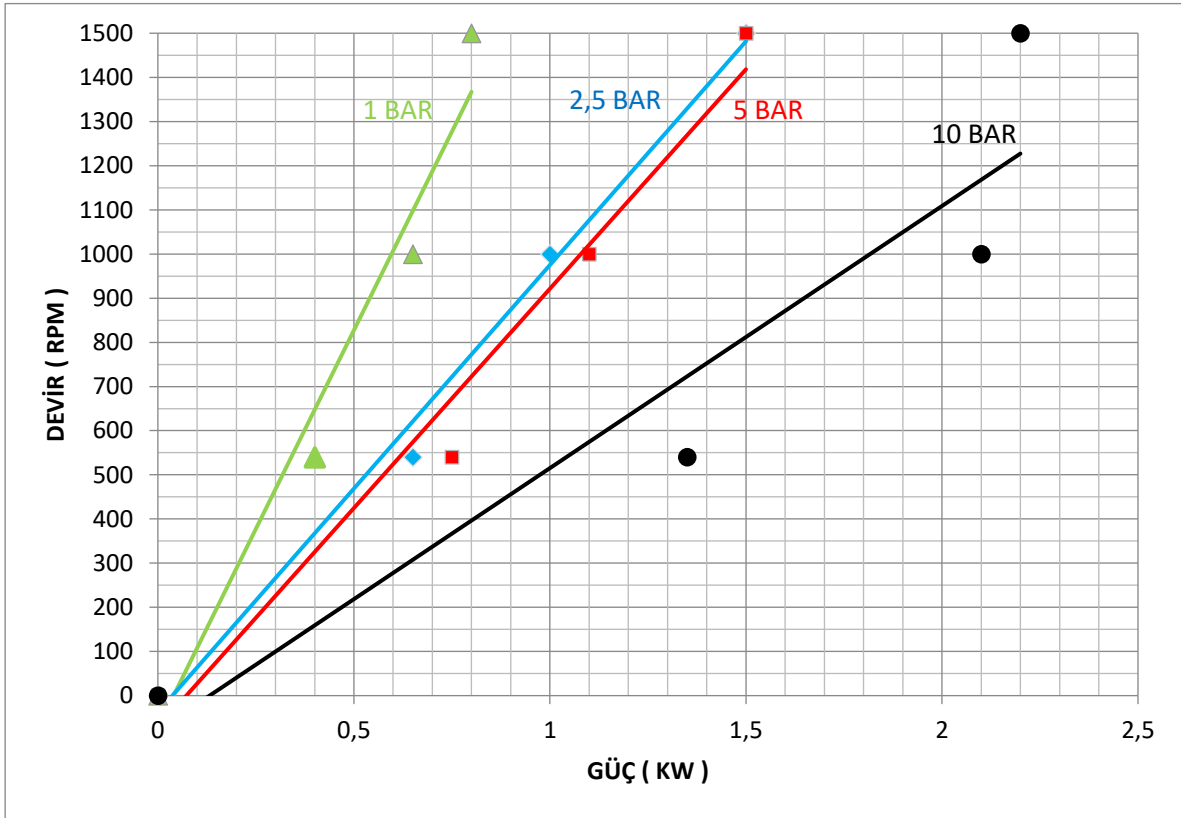

TESTLER SAE30 YAĞ İLE ODA SICAKLIĞINDA ( YAKLAŞIK 100 CST) YAPILMIŞTIR.

## KIPK1½" İÇ DİŞLİ POMPA PERFORMANS EĞRİLERİ

### 1- Devir - Debi

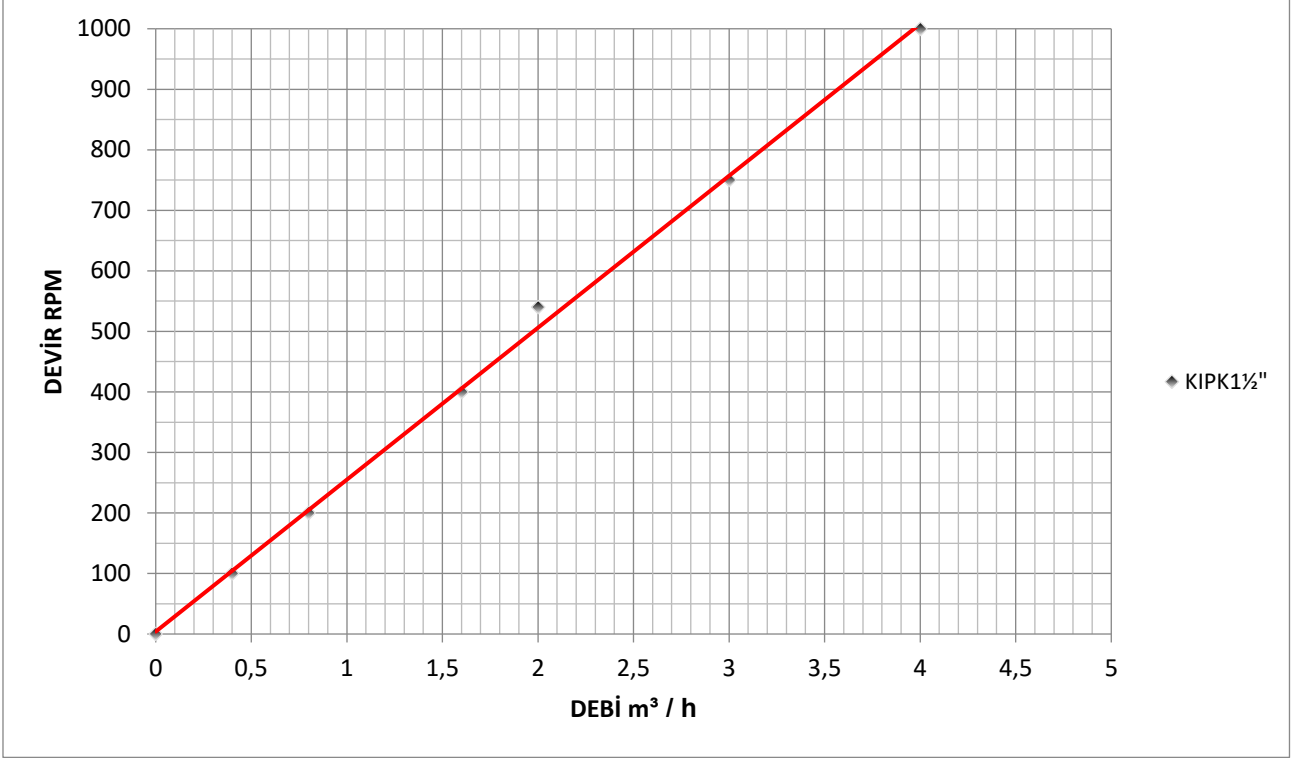

### 2- Devir - Güç - Basınç

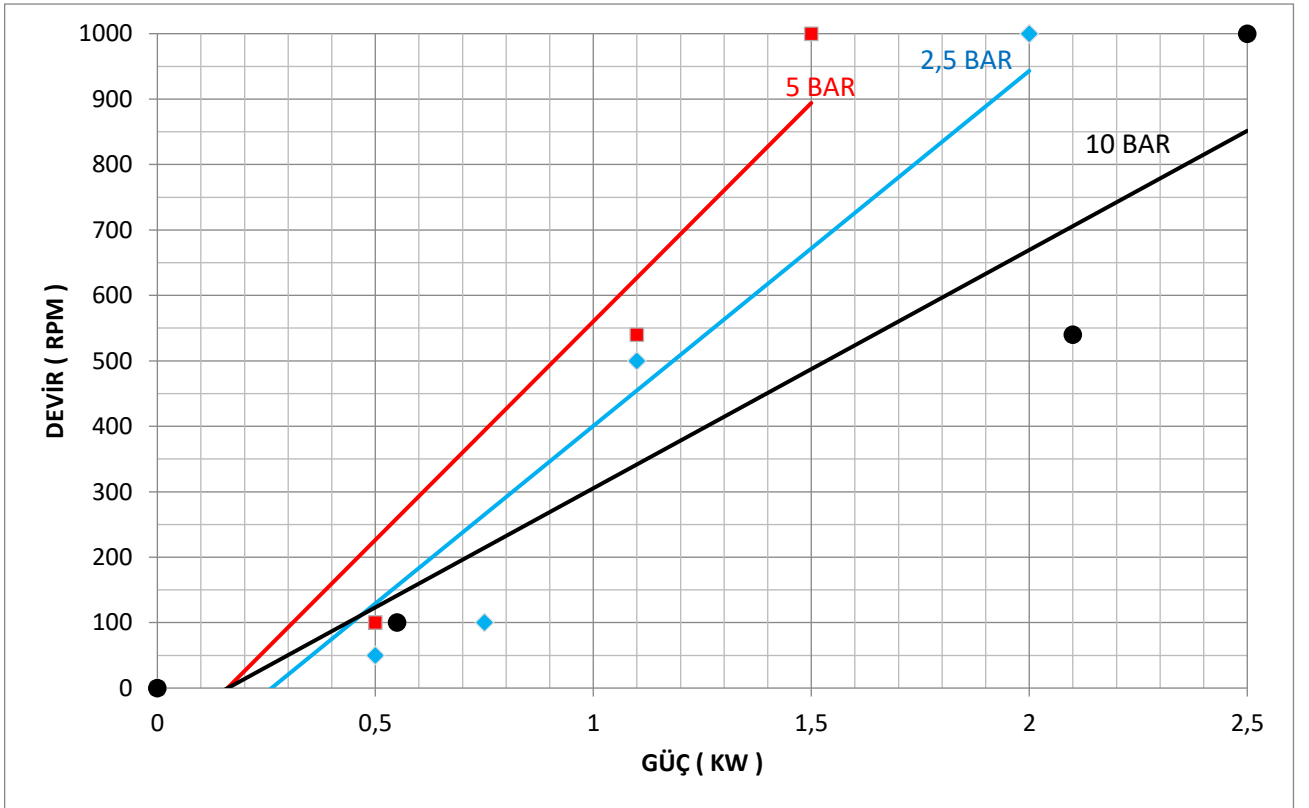

TESTLER SAE30 YAĞ İLE ODA SICAKLIĞINDA ( YAKLAŞIK 100 CST) YAPILMIŞTIR.

## KIPK2" İÇ DİŞLİ POMPA PERFORMANS EĞRİLERİ

### 1- Devir - Debi

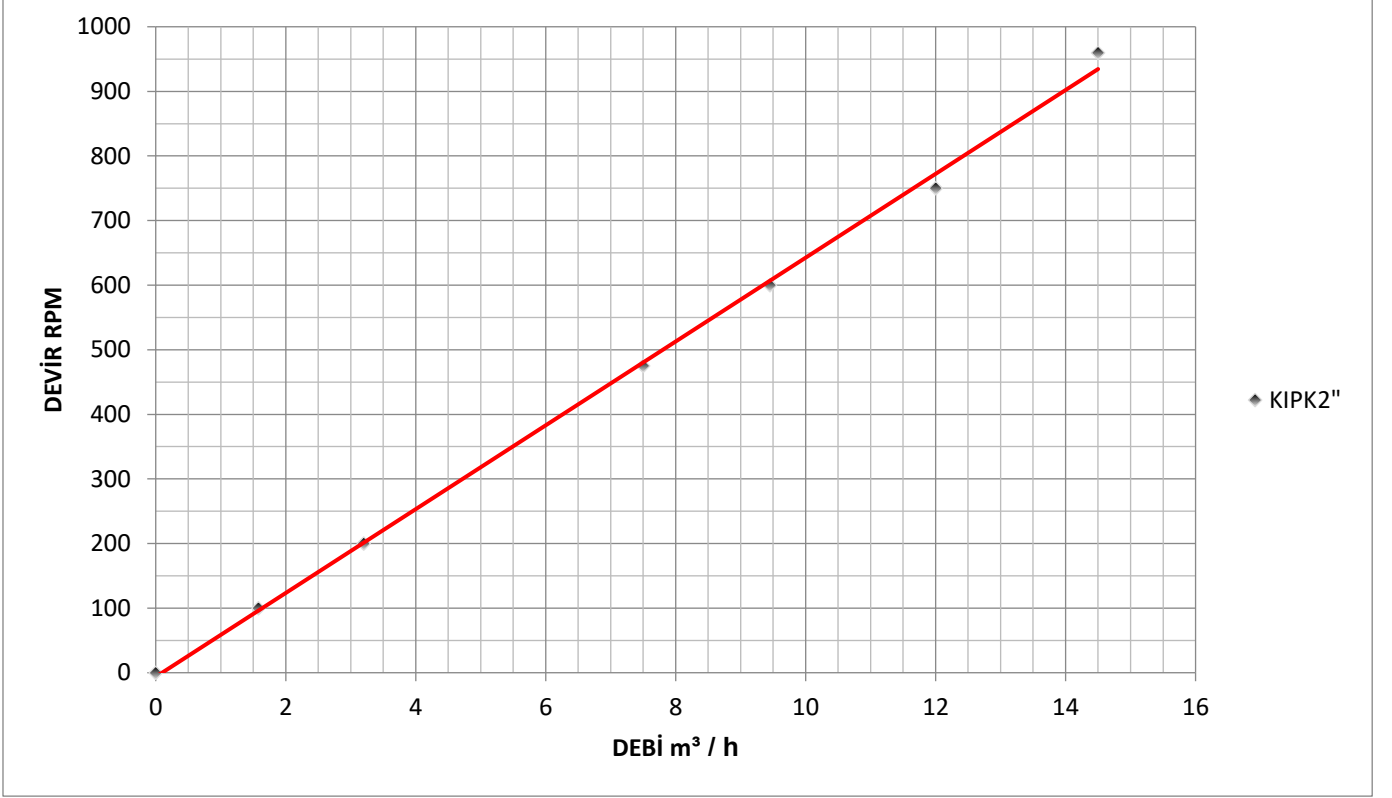

### 2- Devir - Güç - Basınç

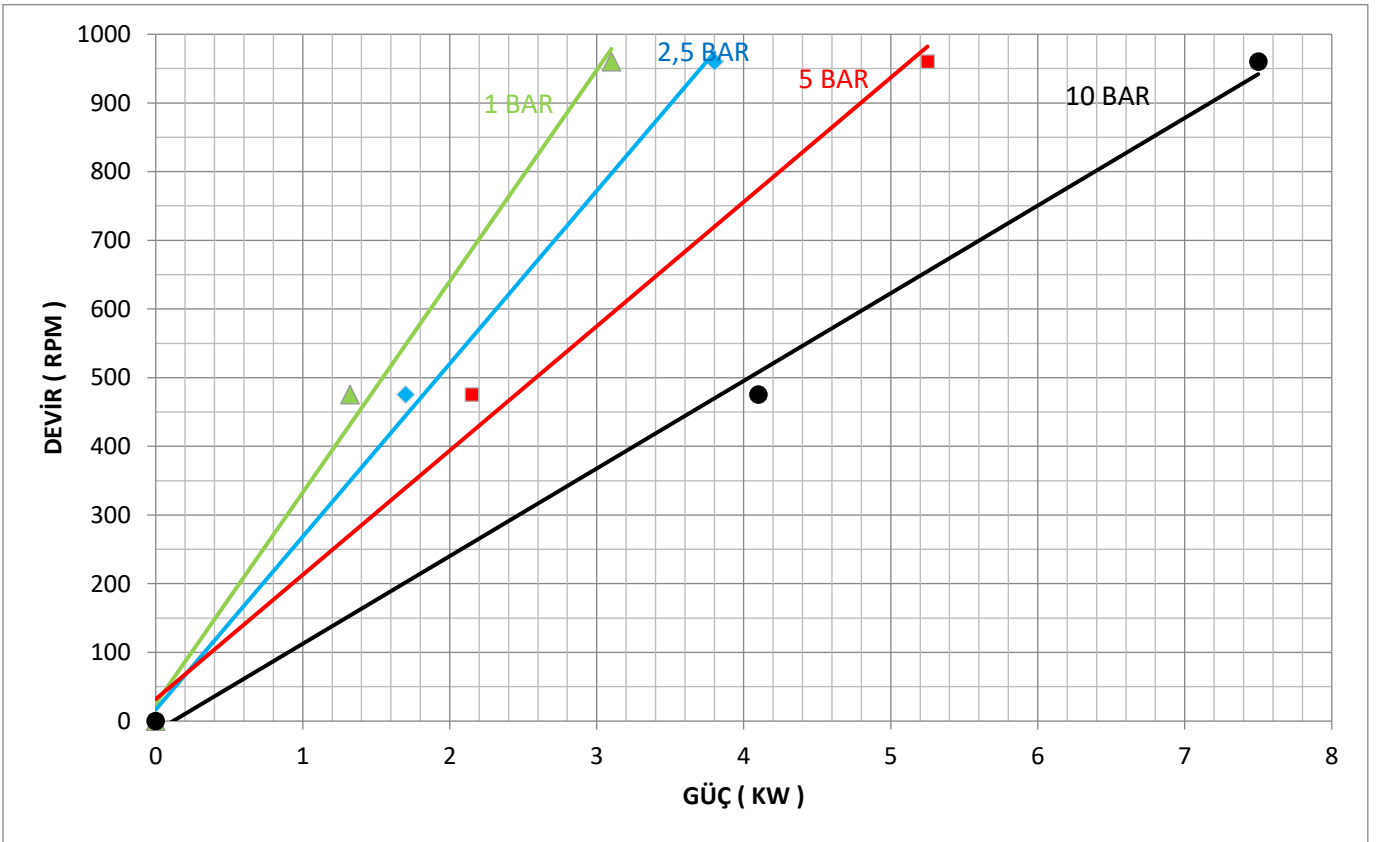

TESTLER SAE30 YAĞ İLE ODA SICAKLIĞINDA (YAKLAŞIK 100 CST) YAPILMIŞTIR.

## KIPK2½" İÇ DİŞLİ POMPA PERFORMANS EĞRİLERİ

### 1- Devir - Debi

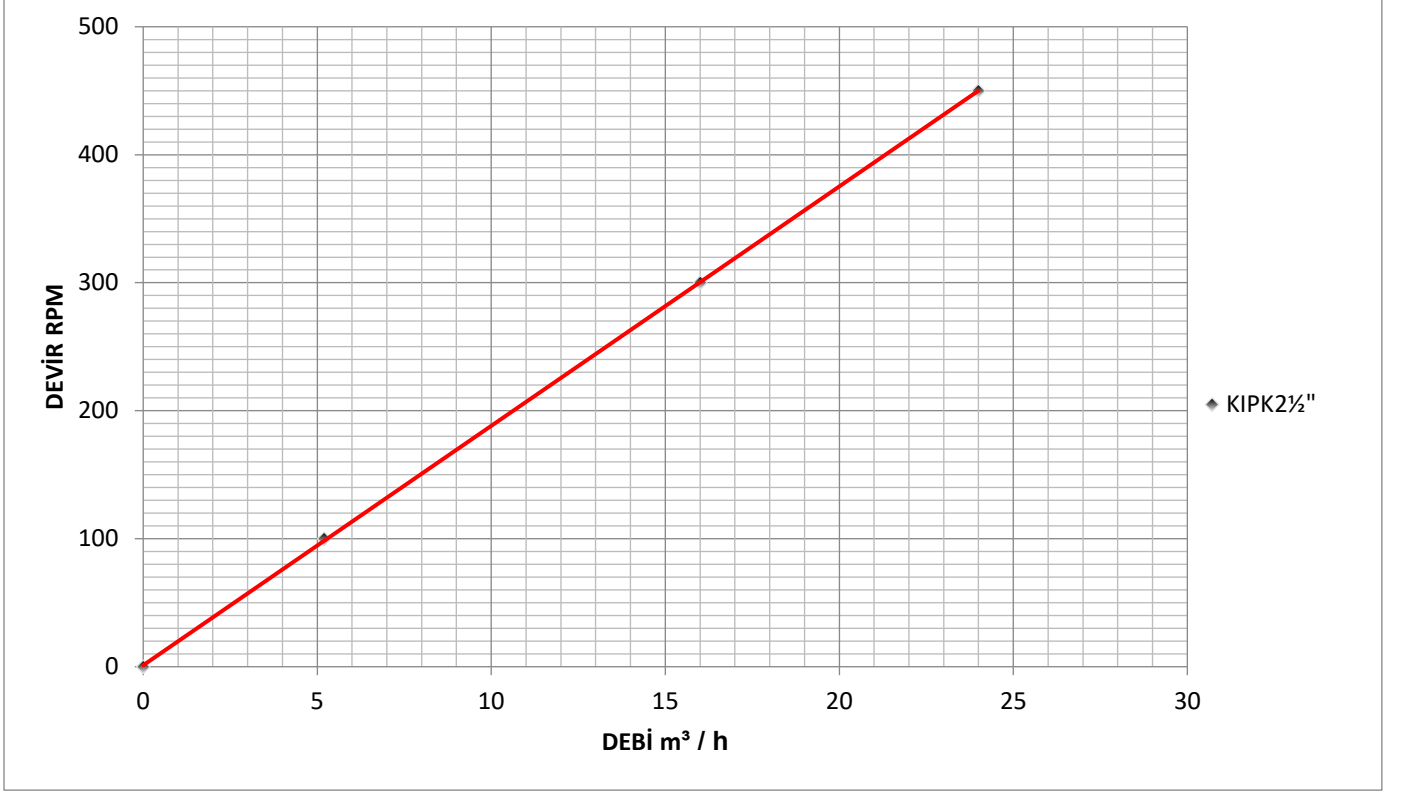

### 2- Devir - Güç - Basınç

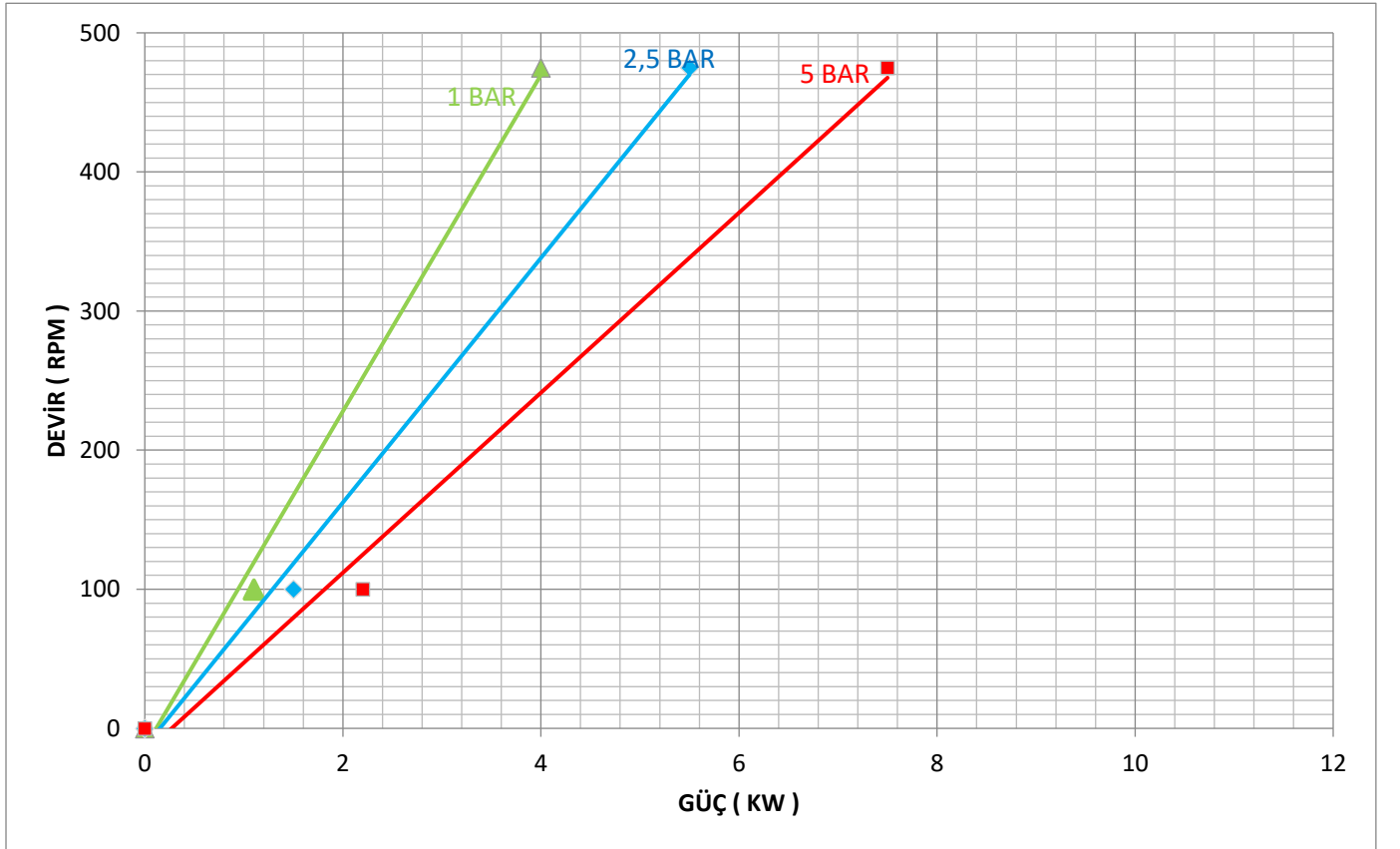

TESTLER SAE30 YAĞ İLE ODA SICAKLIĞINDA ( YAKLAŞIK 100 CST) YAPILMIŞTIR.



## KIP2½" İÇ DİŞLİ POMPA PERFORMANS EĞRİLERİ

### 1- Devir - Debi

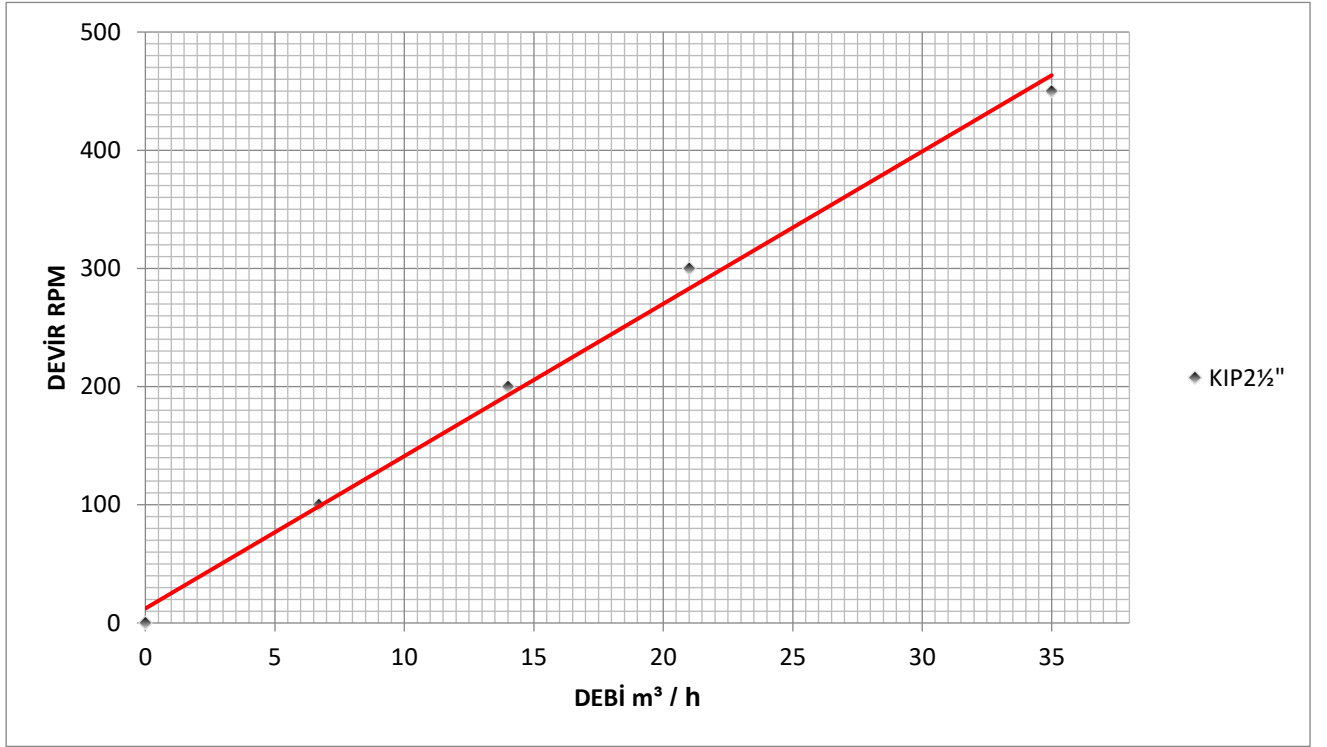

### 2- Devir - Güç - Basınç

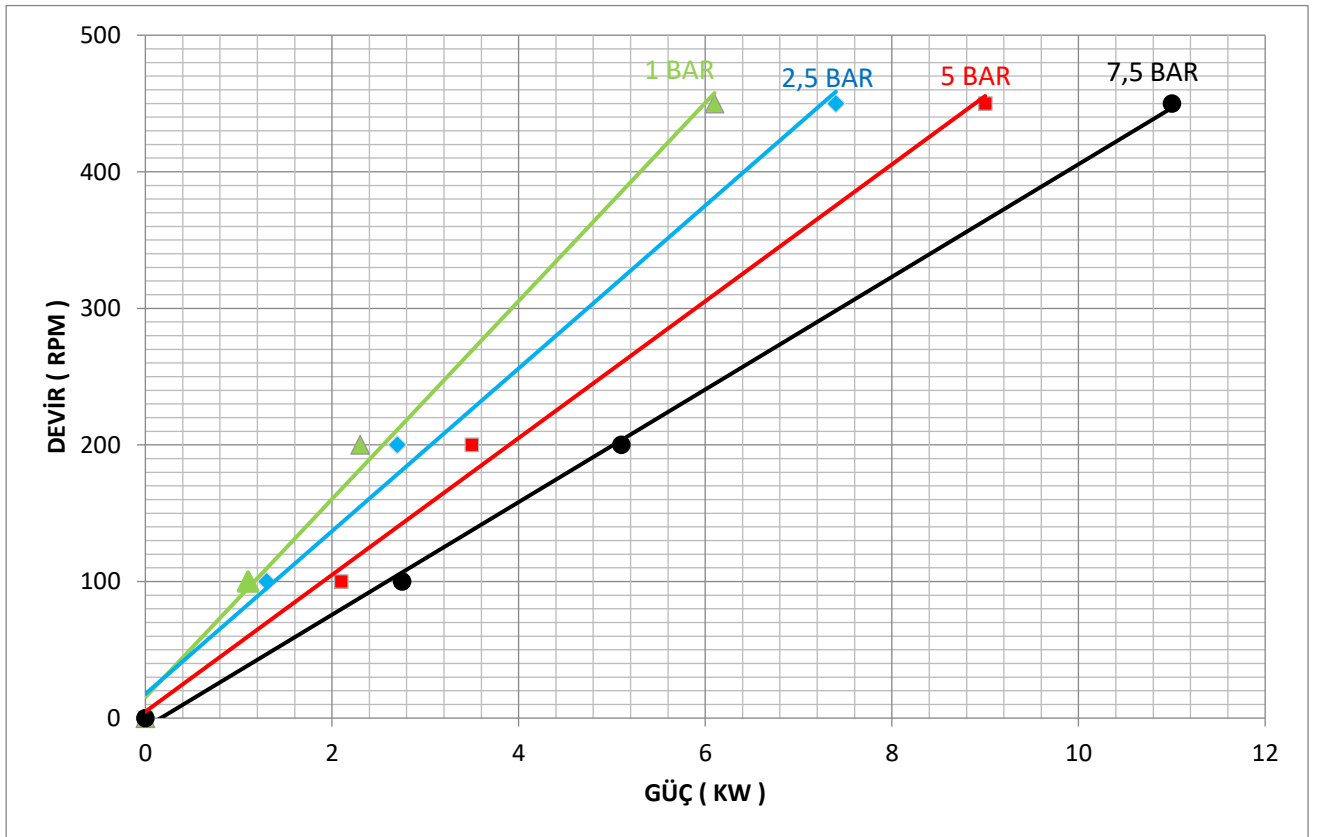

TESTLER SAE30 YAĞ İLE ODA SICAKLIĞINDA ( YAKLAŞIK 100 CST) YAPILMIŞTIR.

## KIP3" İÇ DİŞLİ POMPA PERFORMANS EĞRİLERİ

### 1- Devir - Debi

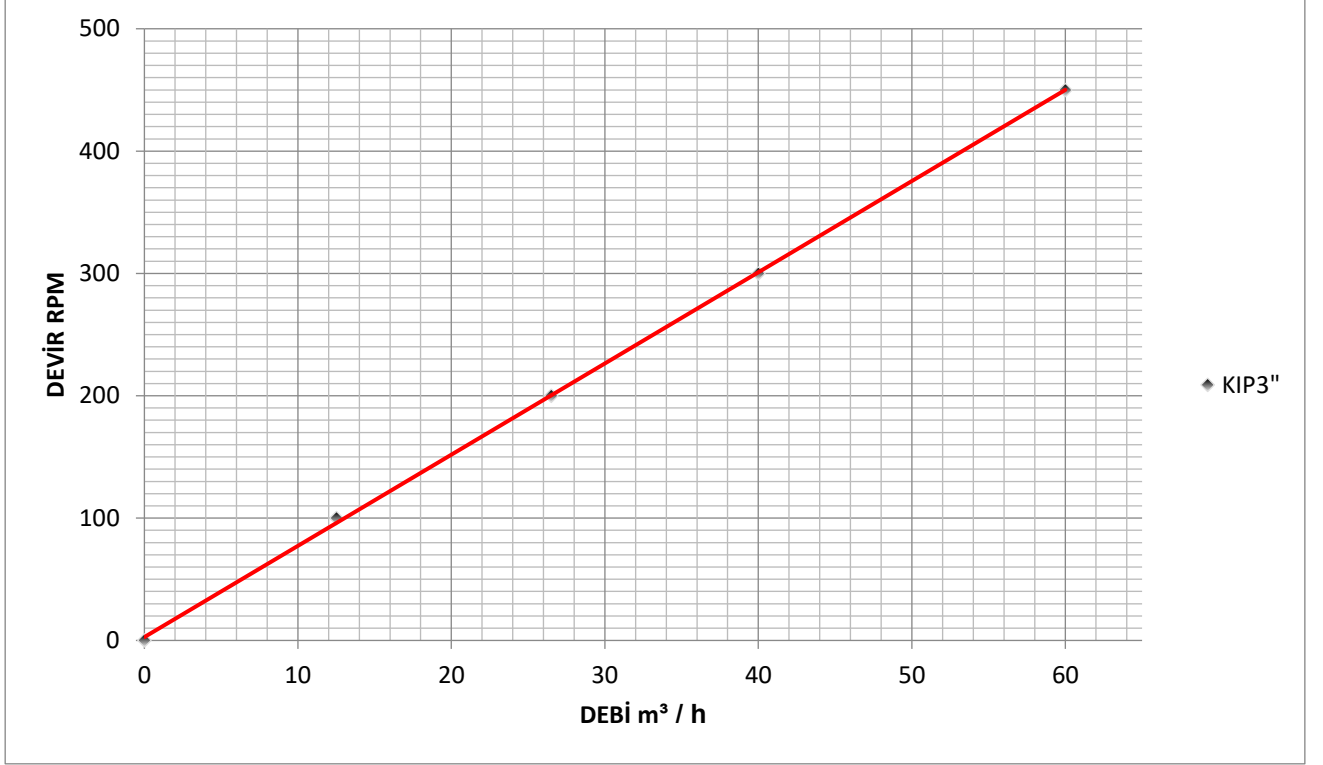

### 2- Devir - Güç - Basınç

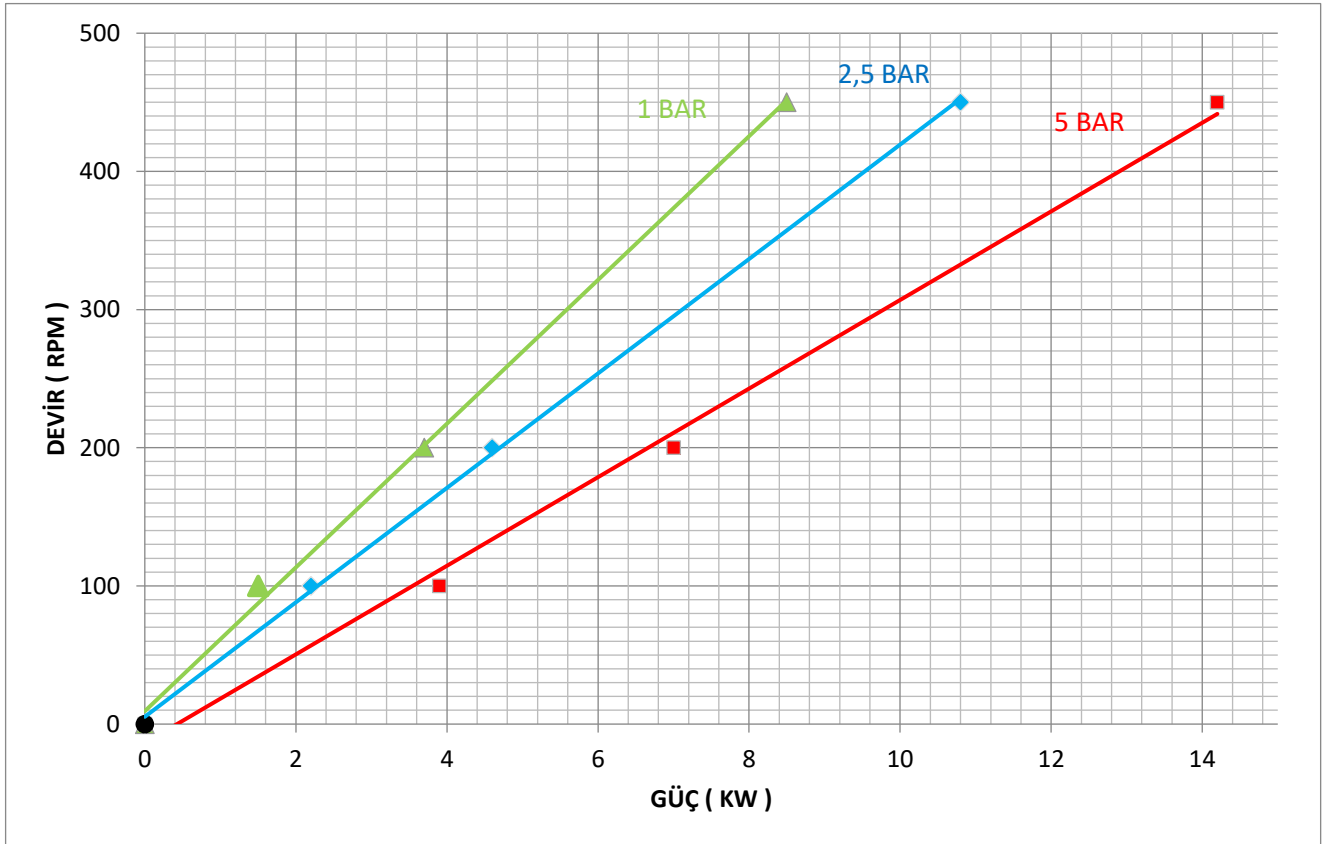

TESTLER SAE30 YAĞ İLE ODA SICAKLIĞINDA ( YAKLAŞIK 100 CST) YAPILMIŞTIR.

## KIP4" İÇ DİŞLİ POMPA PERFORMANS EĞRİLERİ

### 1- Devir - Debi

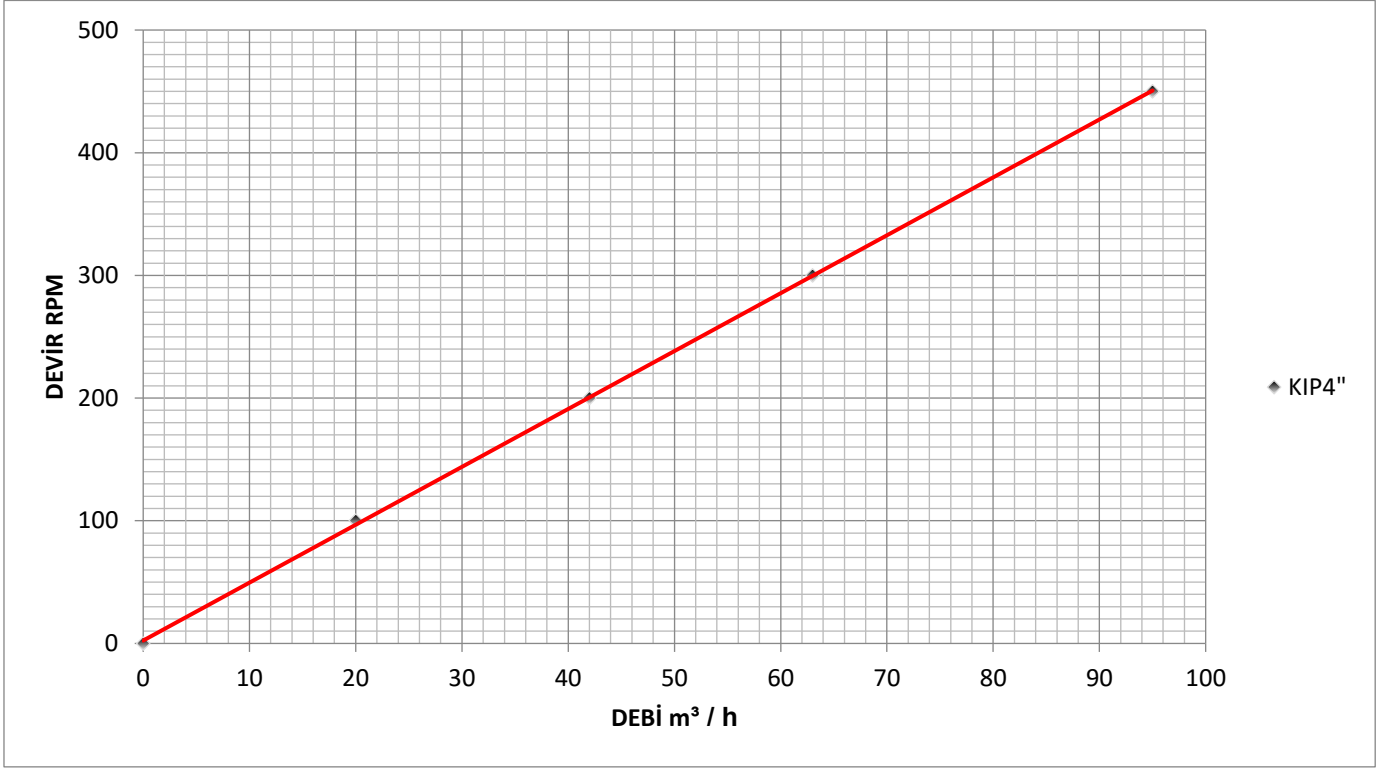

### 2- Devir - Güç - Basınç

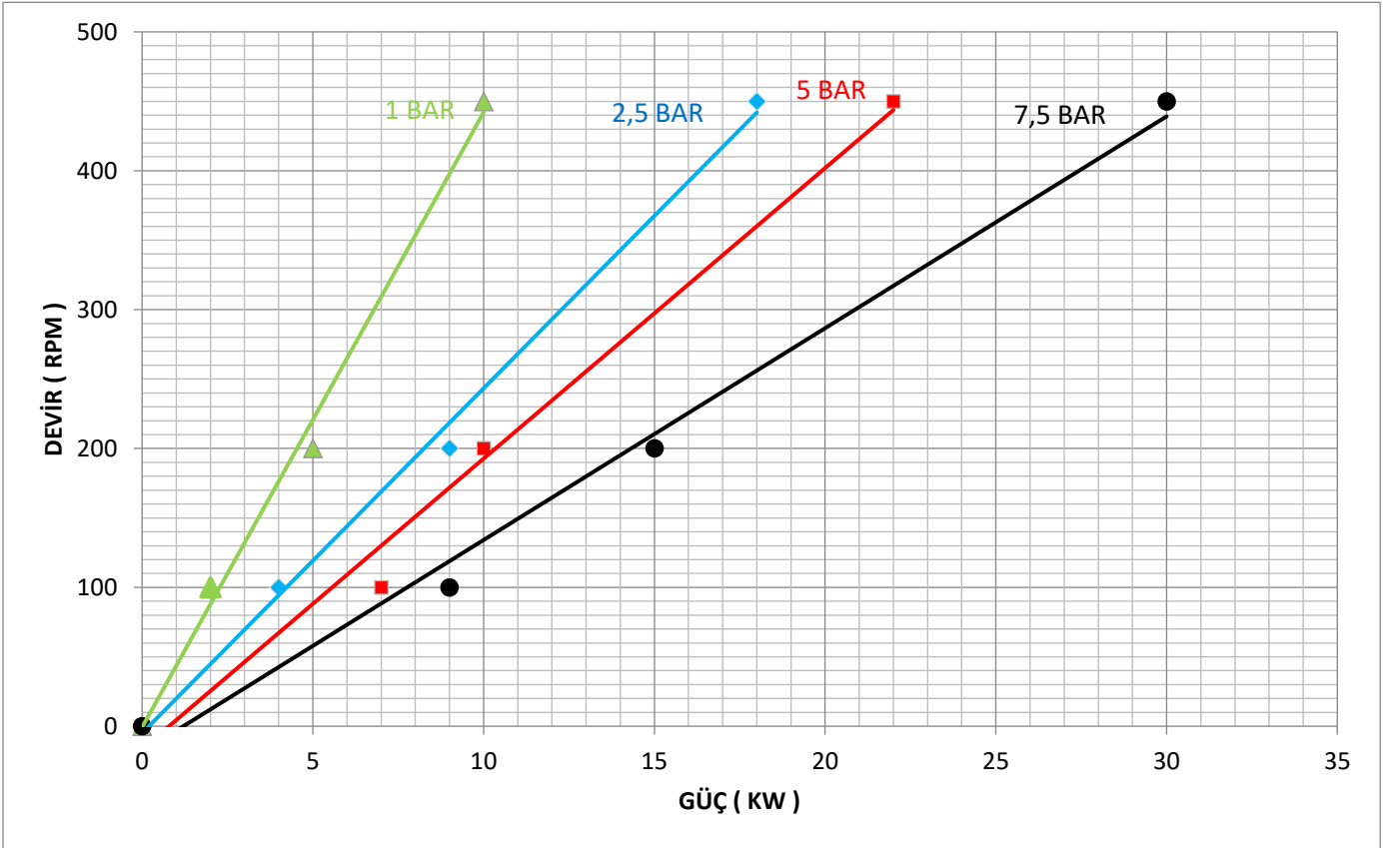

TESTLER SAE30 YAĞ İLE ODA SICAKLIĞINDA ( YAKLAŞIK 100 CST) YAPILMIŞTIR.

## KHP½" HELİS DİŞLİ PERFORMANS EĞRİLERİ

### 1- Devir - Debi

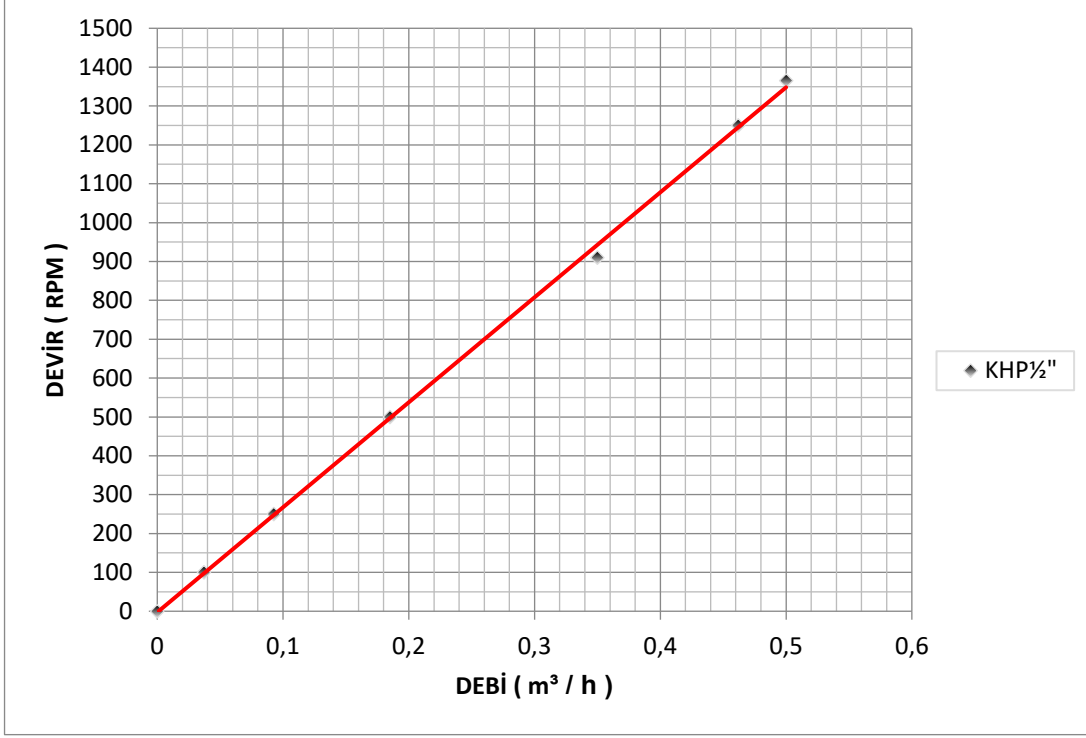

### 2- Devir - Güç - Basınç

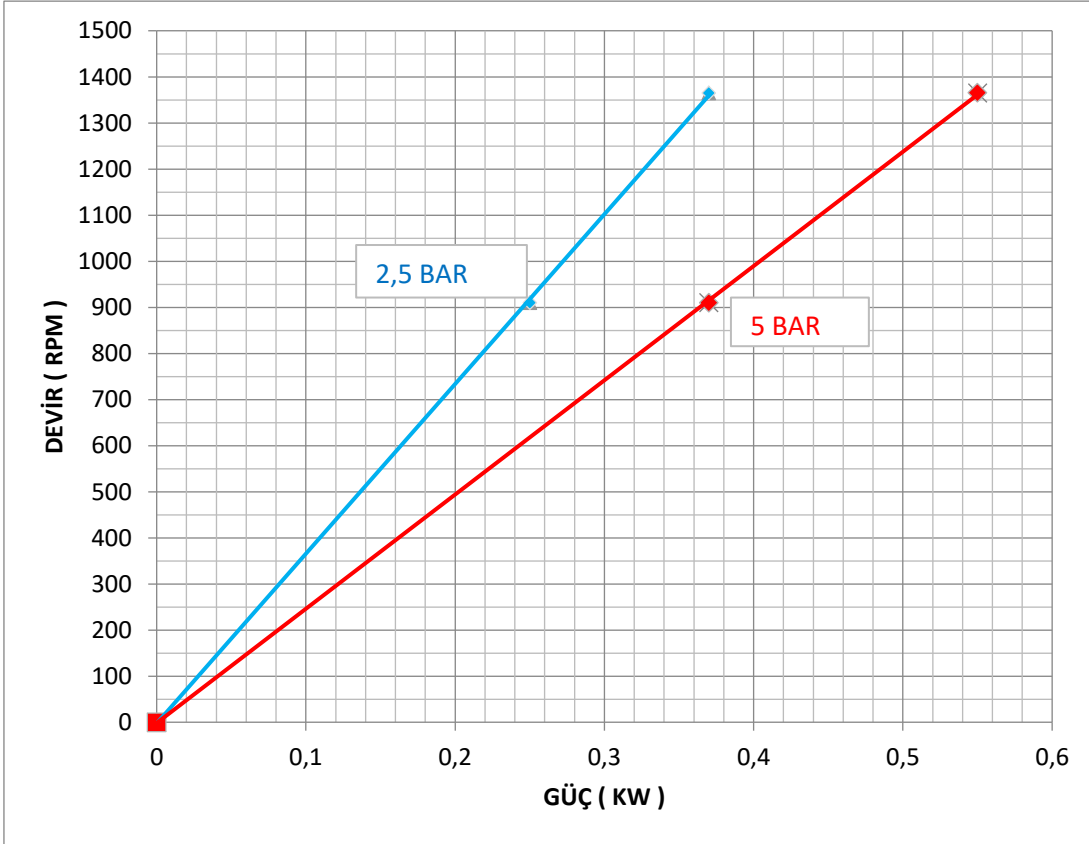

TESTLER SAE30 YAĞ İLE ODA SICAKLIĞINDA (YAKLAŞIK 100 CST) YAPILMIŞTIR.

## KHP1" HELİS DİŞLİ PERFORMANS EĞRİLERİ

### 1- Devir - Debi

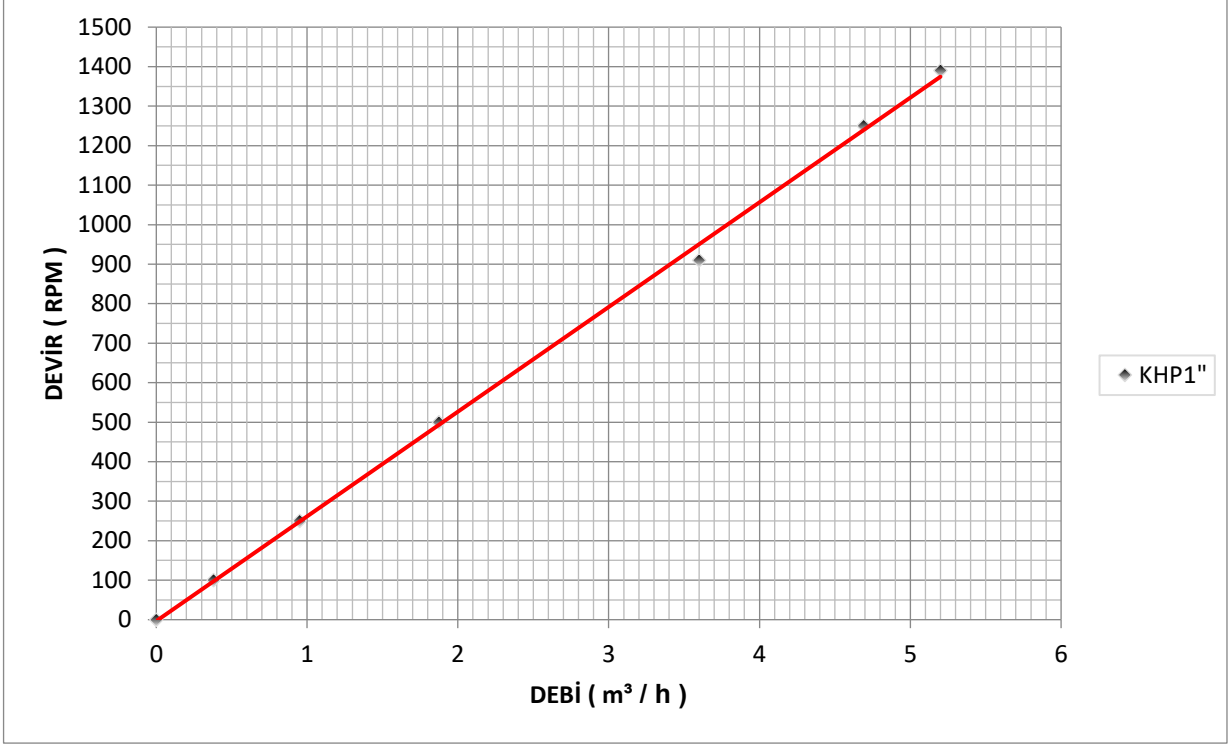

### 2- Devir - Güç - Basınç

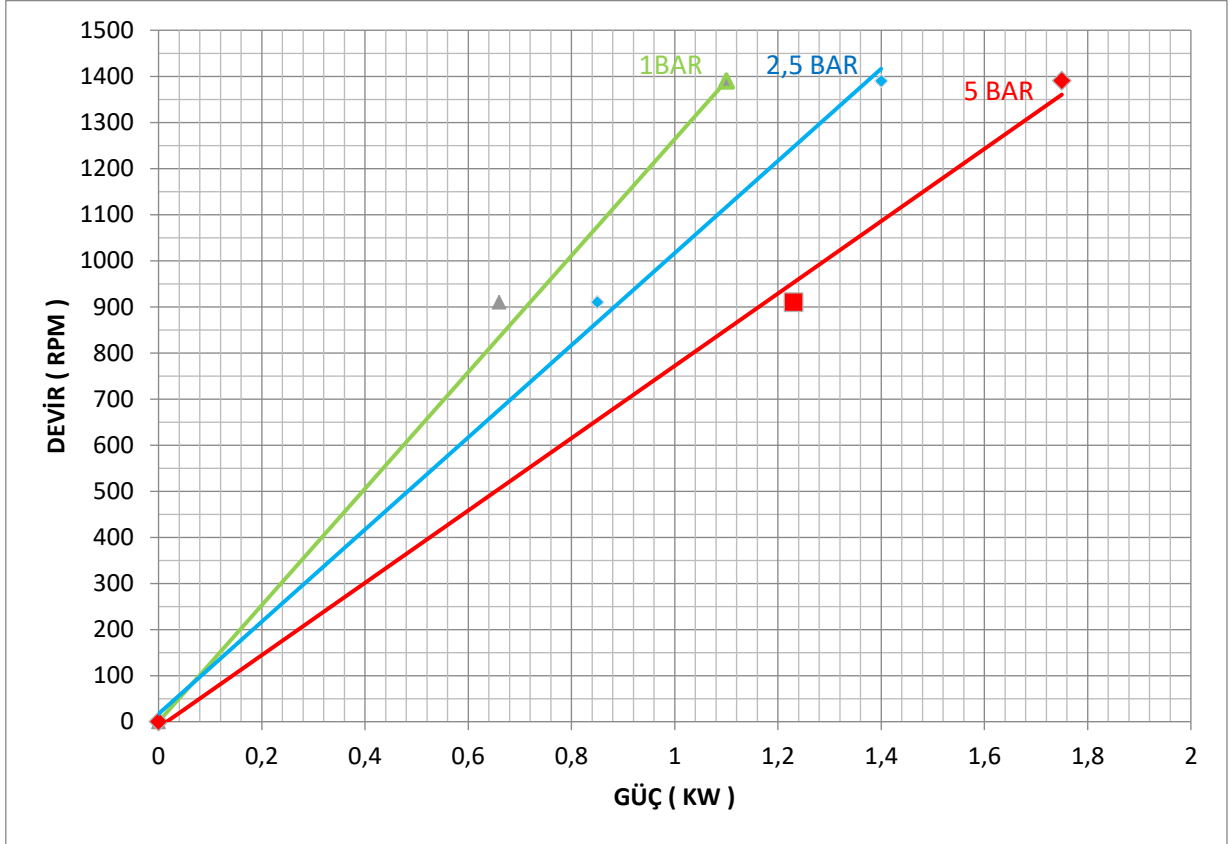

TESTLER SAE30 YAĞ İLE ODA SICAKLIĞINDA (YAKLAŞIK 100 CST) YAPILMIŞTIR.

## KHP1" HELİS DİŞLİ PERFORMANS EĞRİLERİ

### 1- Devir - Debi

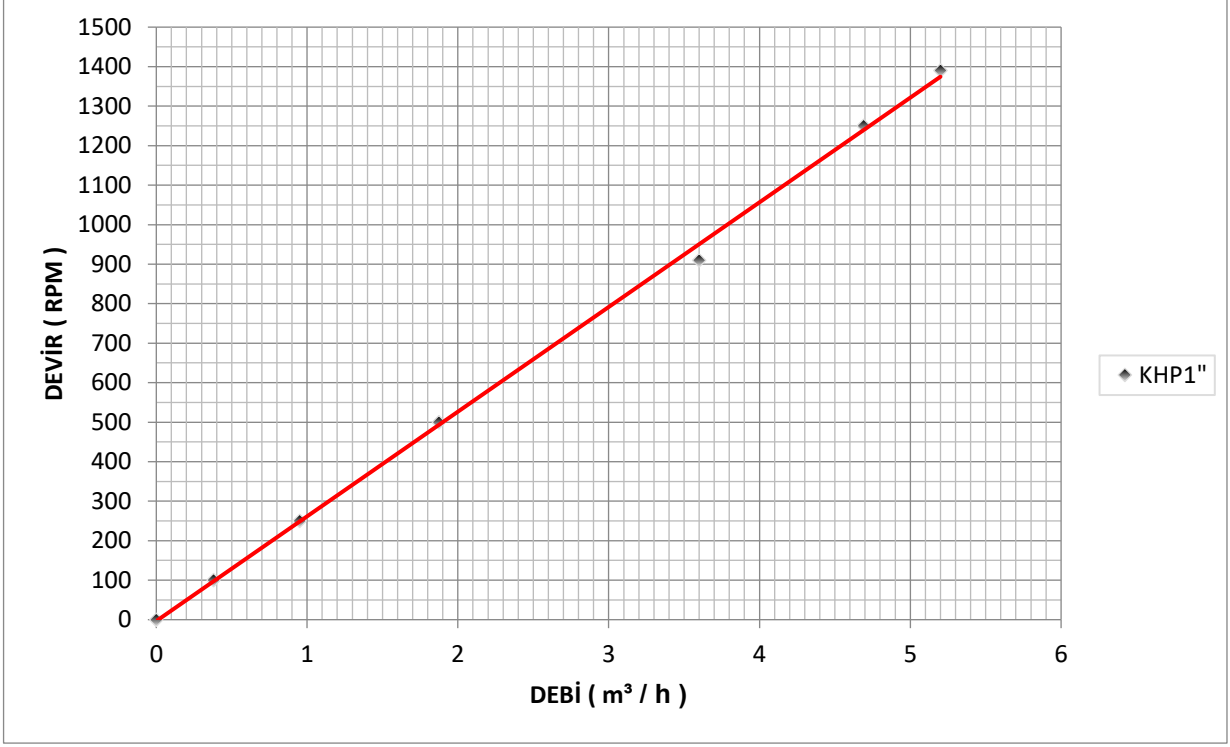

### 2- Devir - Güç - Basınç

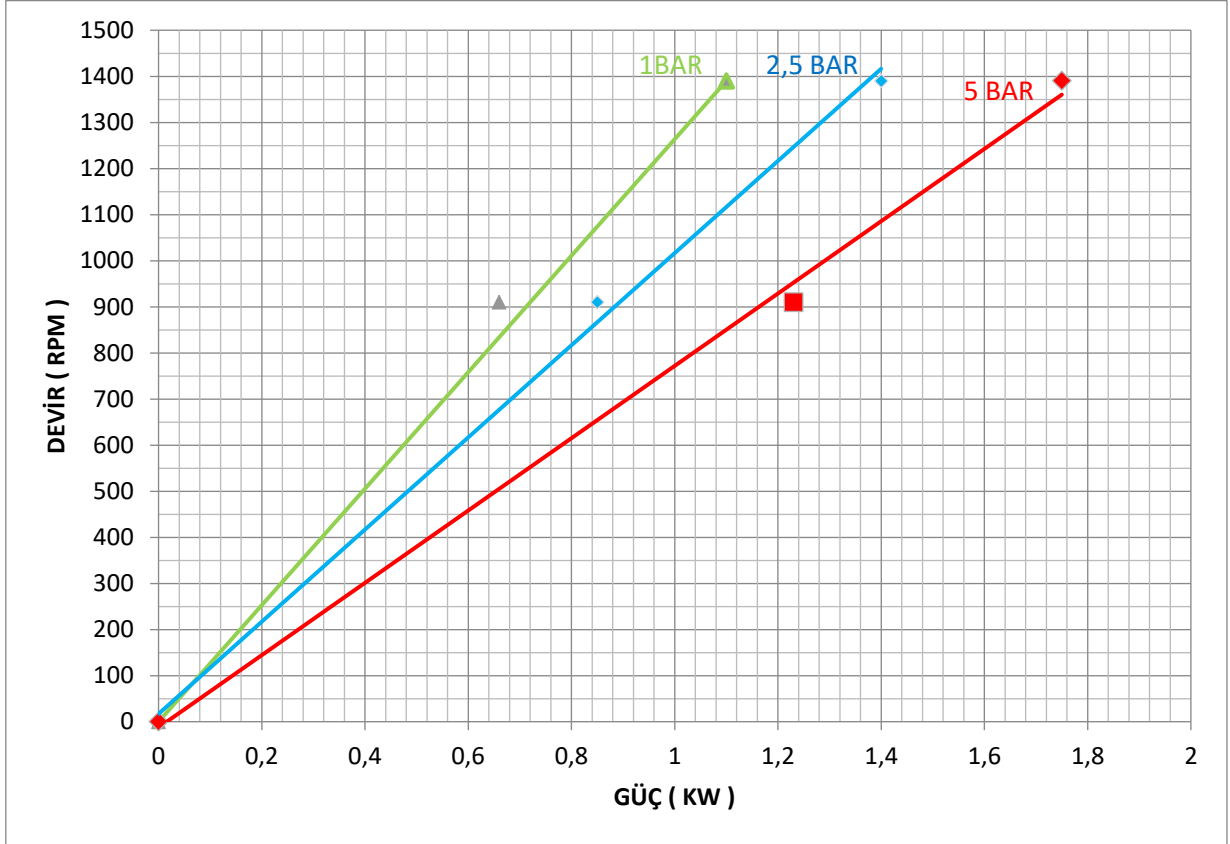

TESTLER SAE30 YAĞ İLE ODA SICAKLIĞINDA (YAKLAŞIK 100 CST) YAPILMIŞTIR.

## KHP1½" HELİS DİŞLİ PERFORMANS EĞRİLERİ

### 1- Devir - Debi

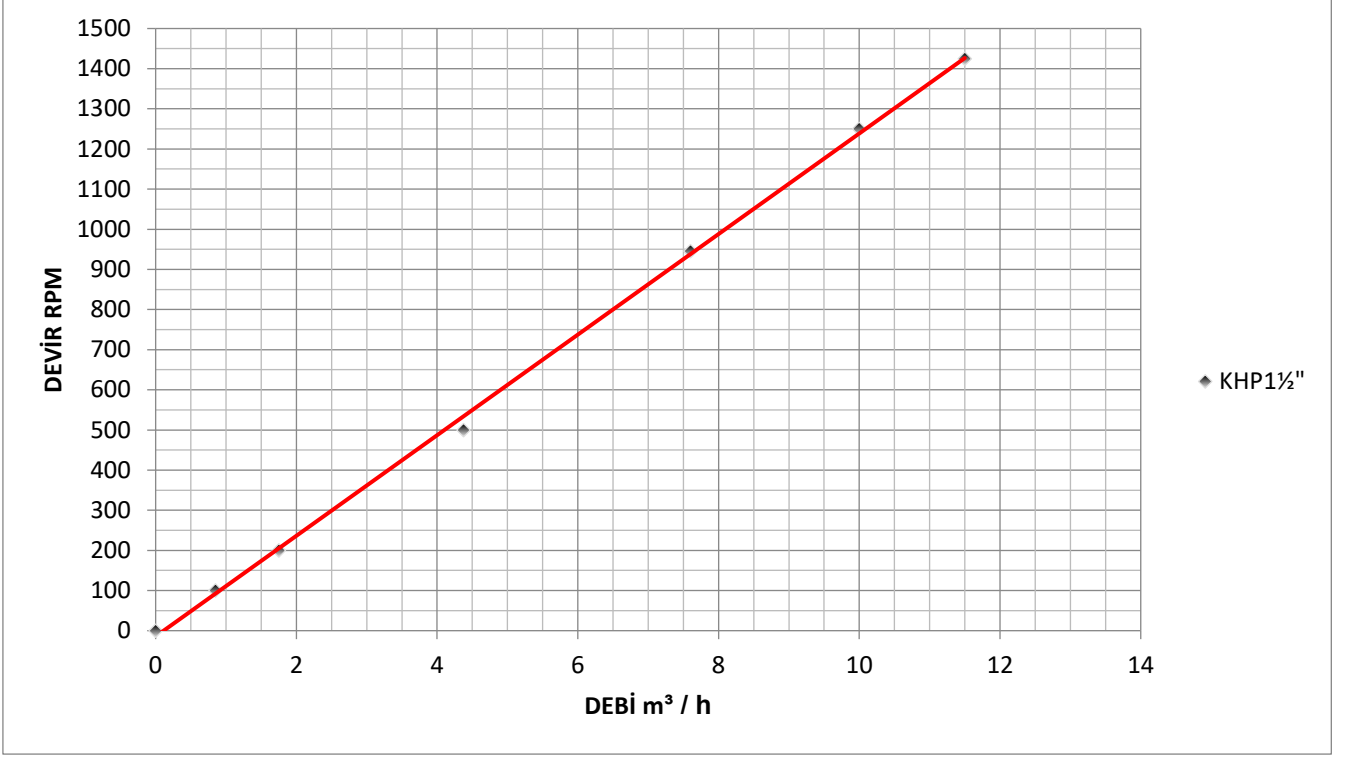

### 2- Devir - Güç - Basınç

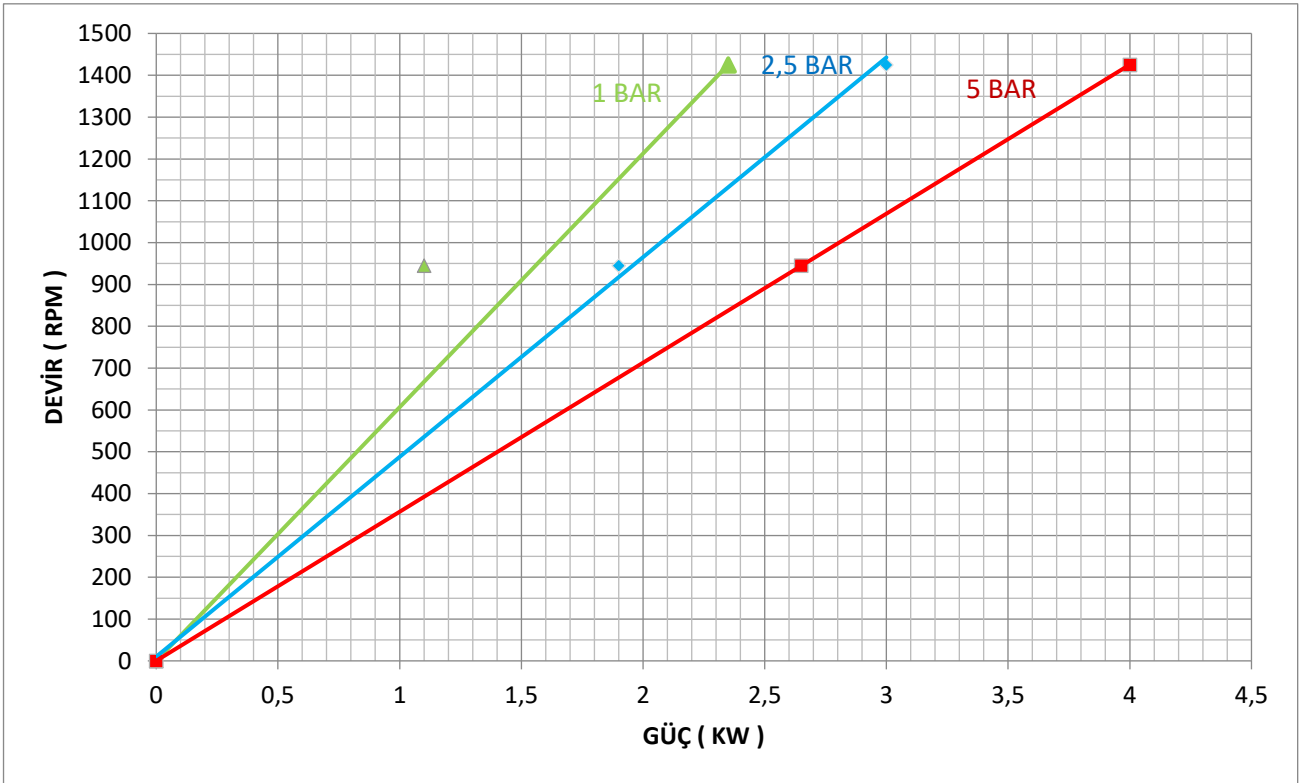

TESTLER SAE30 YAĞ İLE ODA SICAKLIĞINDA ( YAKLAŞIK 100 CST) YAPILMIŞTIR.

## KHP1½" HELİS DİŞLİ PERFORMANS EĞRİLERİ

### 1- Devir - Debi

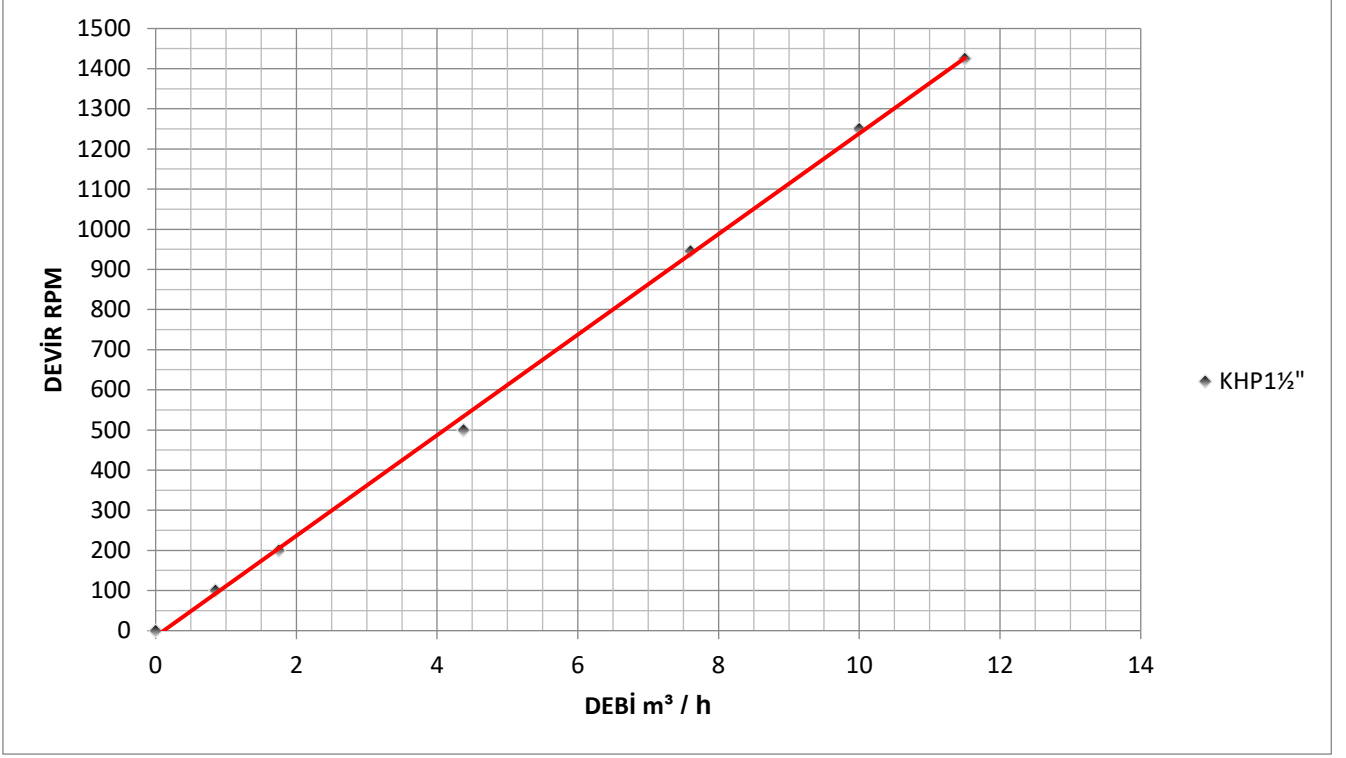

### 2- Devir - Güç - Basınç

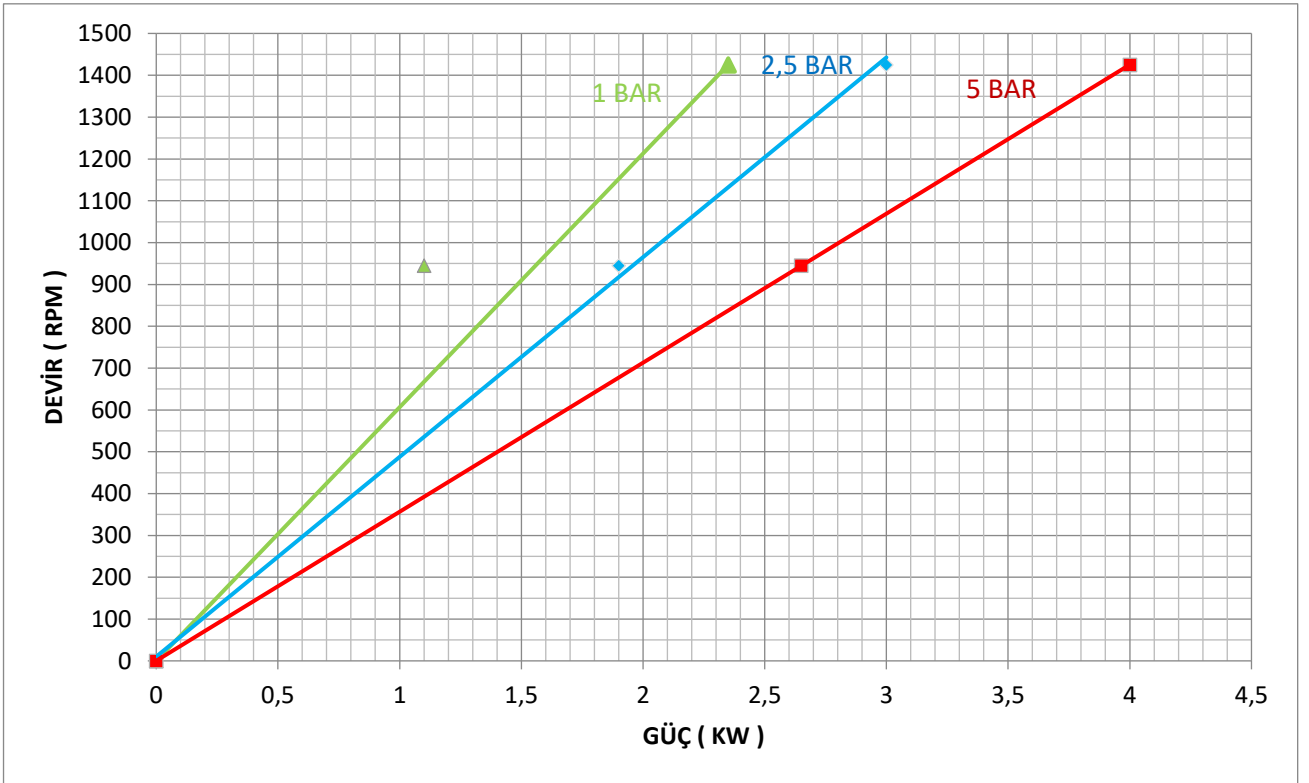

TESTLER SAE30 YAĞ İLE ODA SICAKLIĞINDA (YAKLAŞIK 100 CST) YAPILMIŞTIR.



## KHP2" HELİS DİŞLİ PERFORMANS EĞRİLERİ

### 1- Devir - Debi

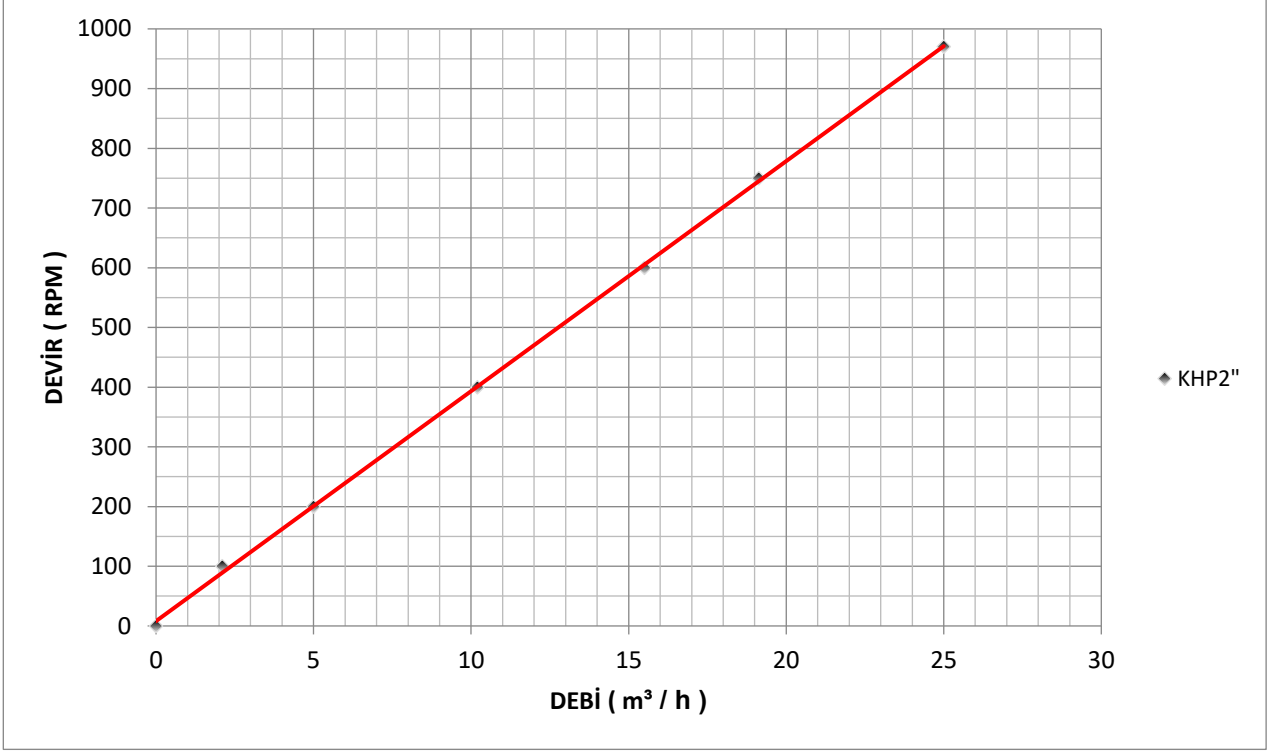

### 2- Devir - Güç - Basınç

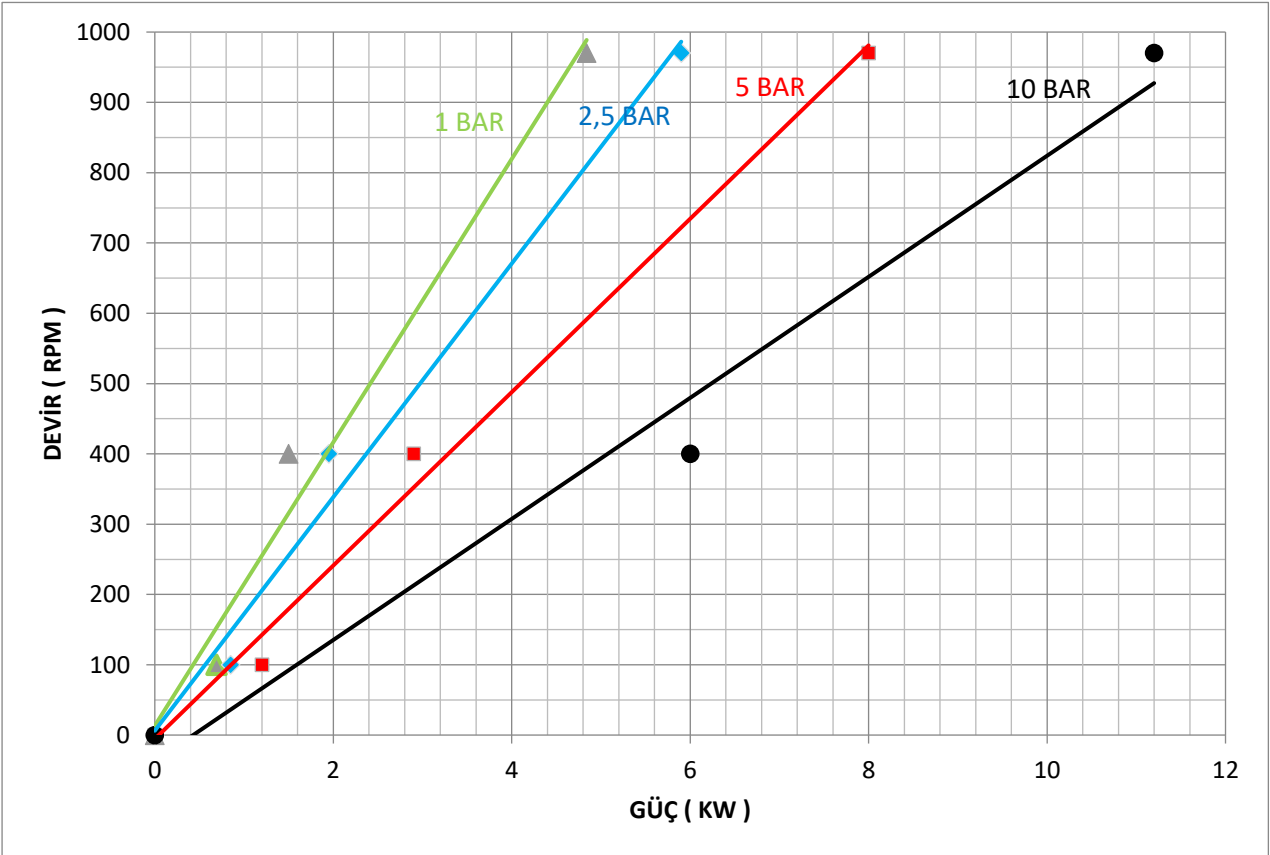

TESTLER SAE30 YAĞ İLE ODA SICAKLIĞINDA (YAKLAŞIK 100 CST) YAPILMIŞTIR.

## KHP2" HELİS DİŐLİ PERFORMANS EĐRİLERİ

### 1- Devir - Debi

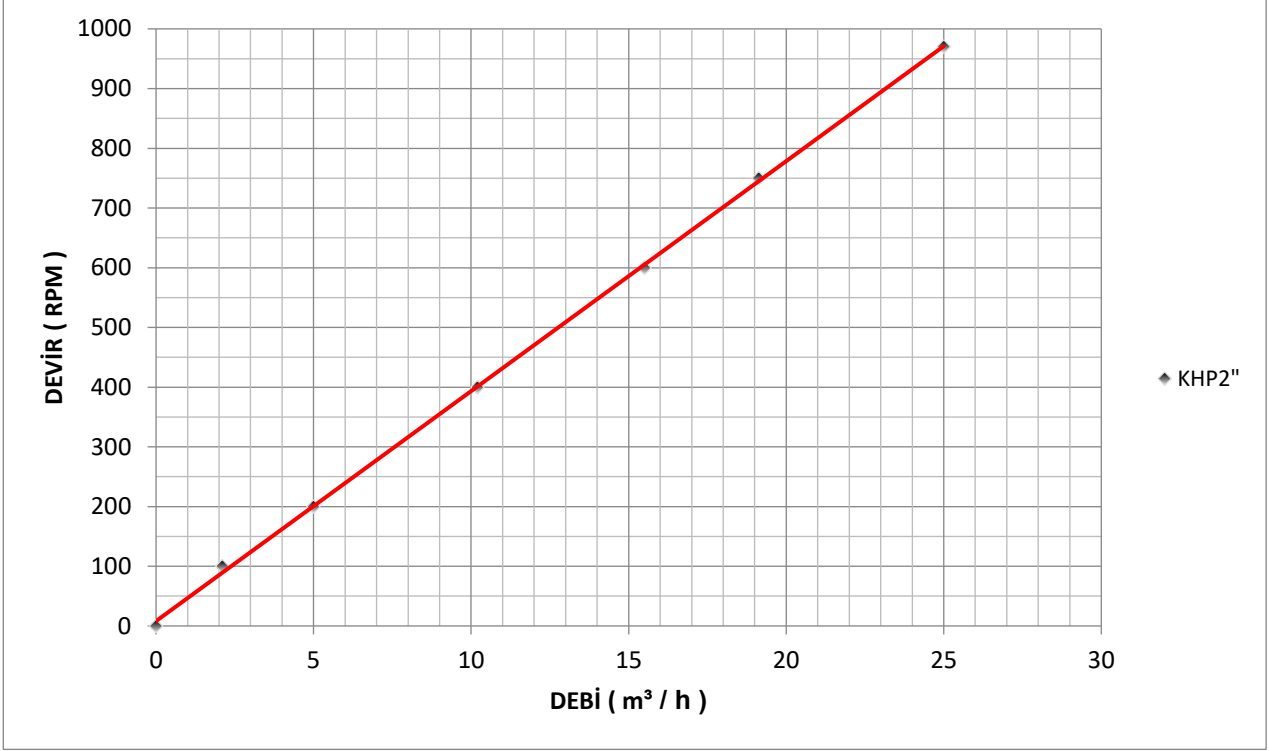

### 2- Devir - Güç - Basınç

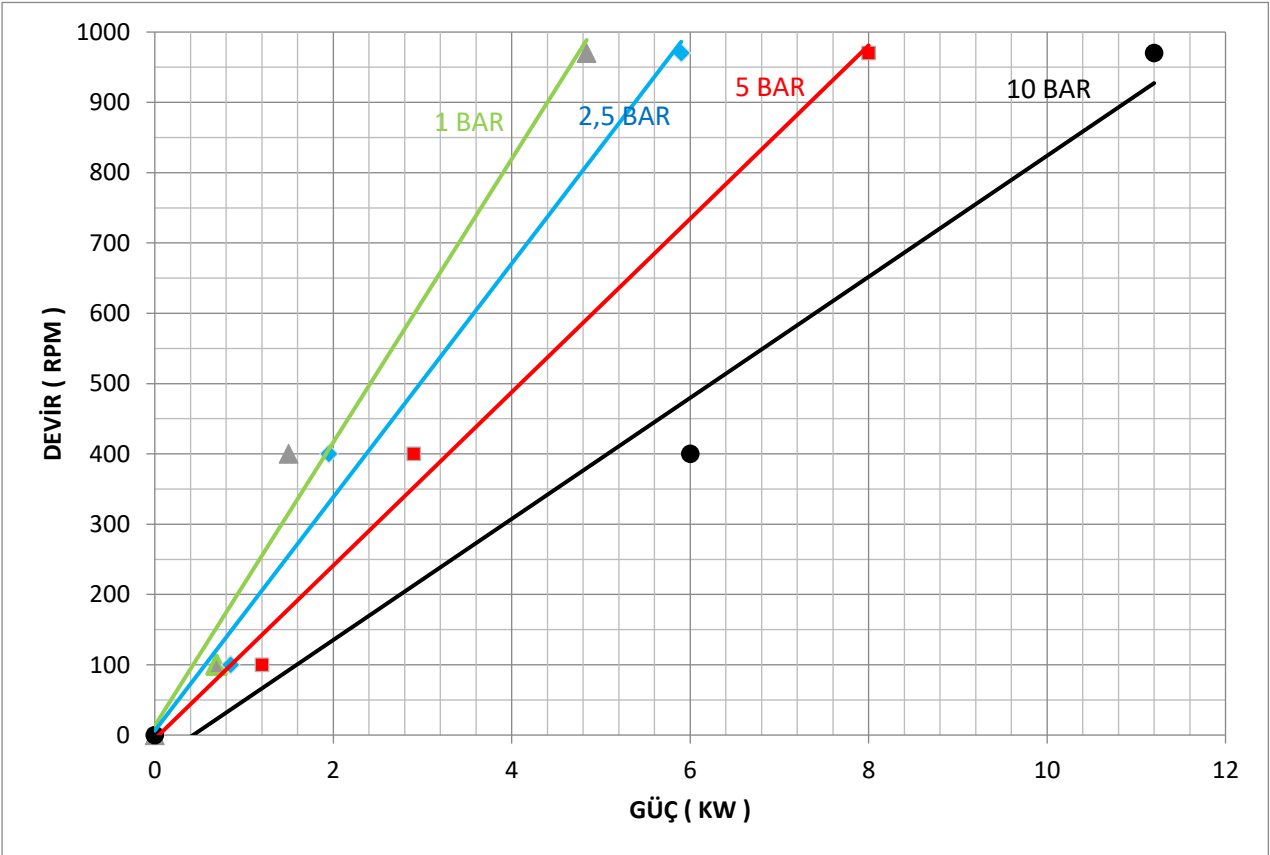

TESTLER SAE30 YAĐ İLE ODA SICAKLIĐINDA ( YAKLAŐIK 100 CST) YAPILMIŐTIR.

## KHP2½" HELİS DİŞLİ PERFORMANS EĞRİLERİ

### 1- Devir - Debi

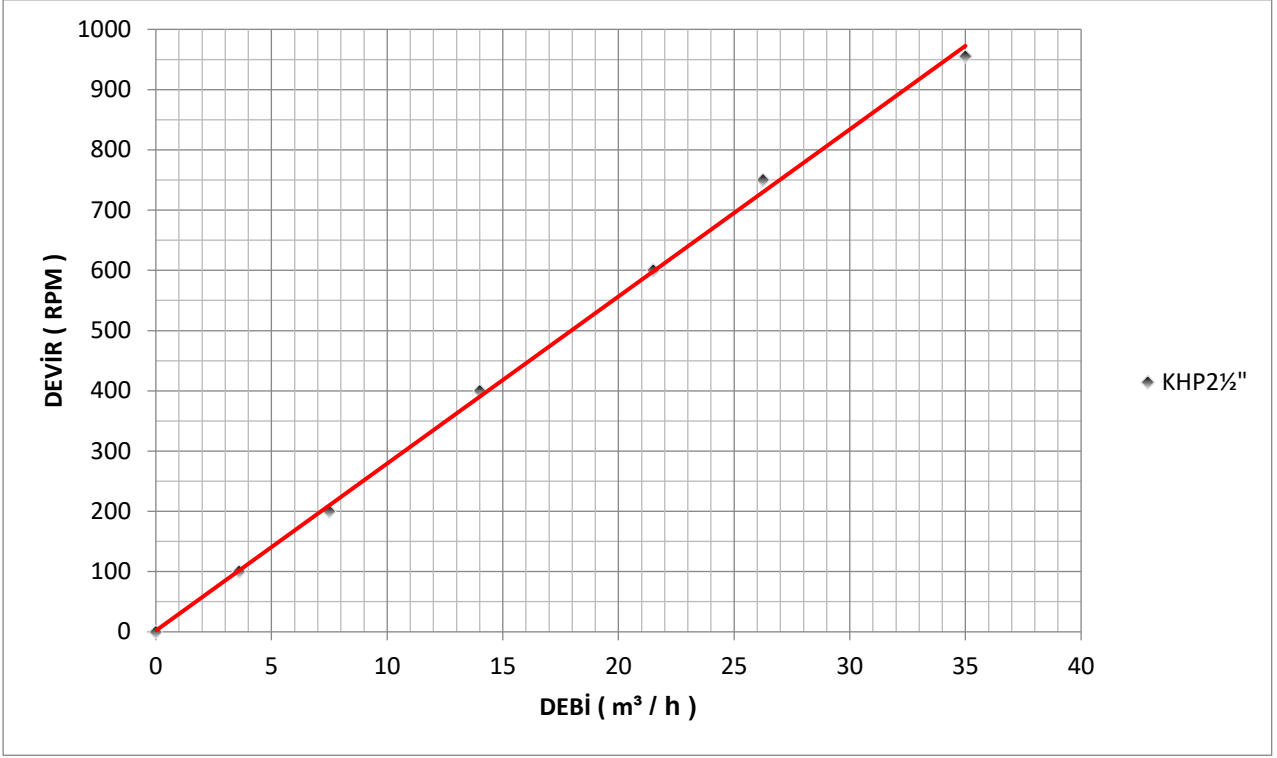

### 2- Devir - Güç - Basınç

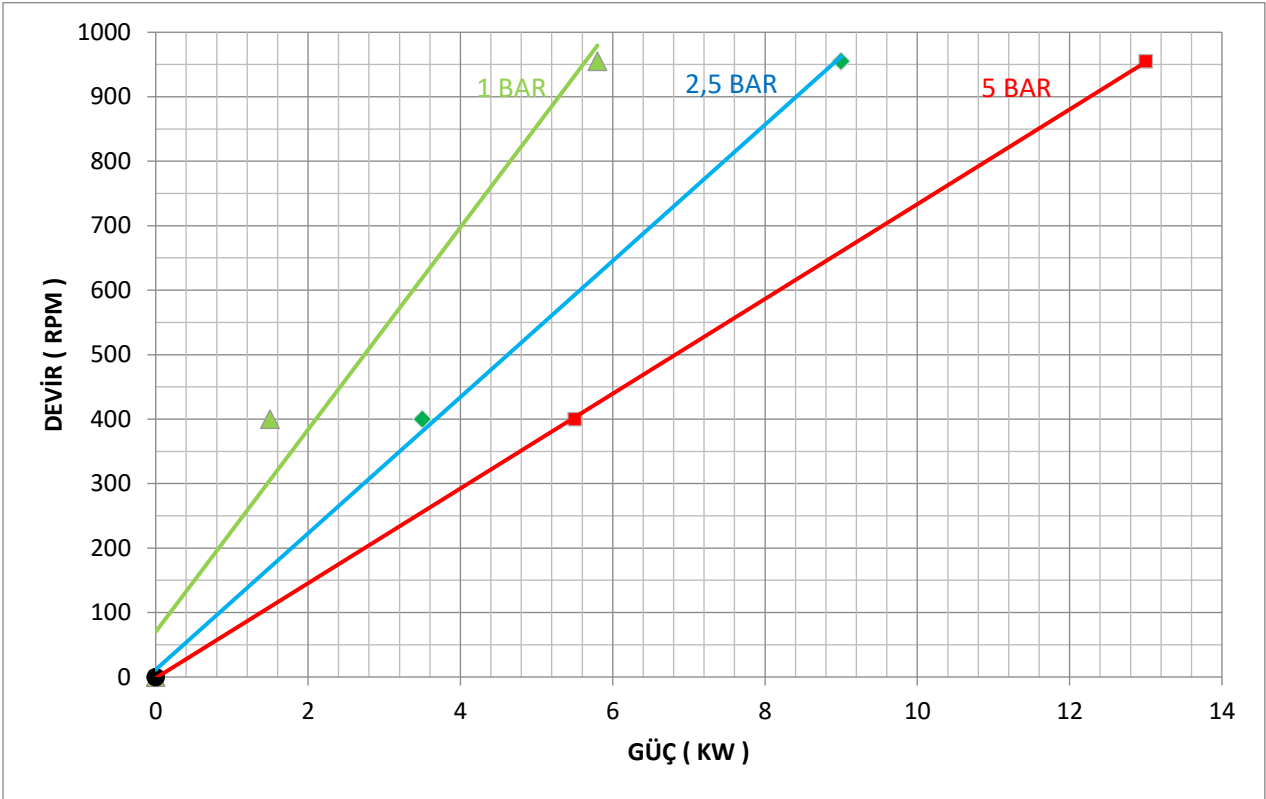

TESTLER SAE30 YAĞ İLE ODA SICAKLIĞINDA (YAKLAŞIK 100 CST) YAPILMIŞTIR.

## KHP2½" HELİS DİŞLİ PERFORMANS EĞRİLERİ

### 1- Devir - Debi

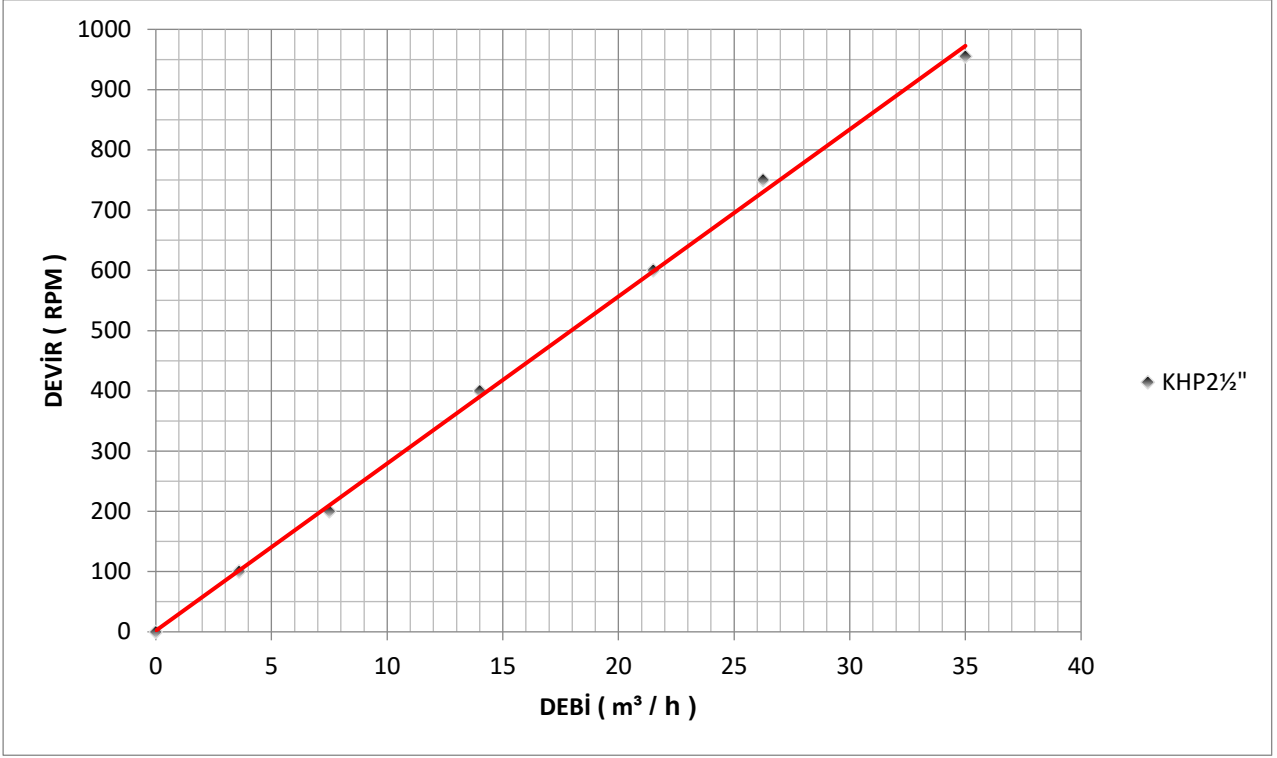

### 2- Devir - Güç - Basınç

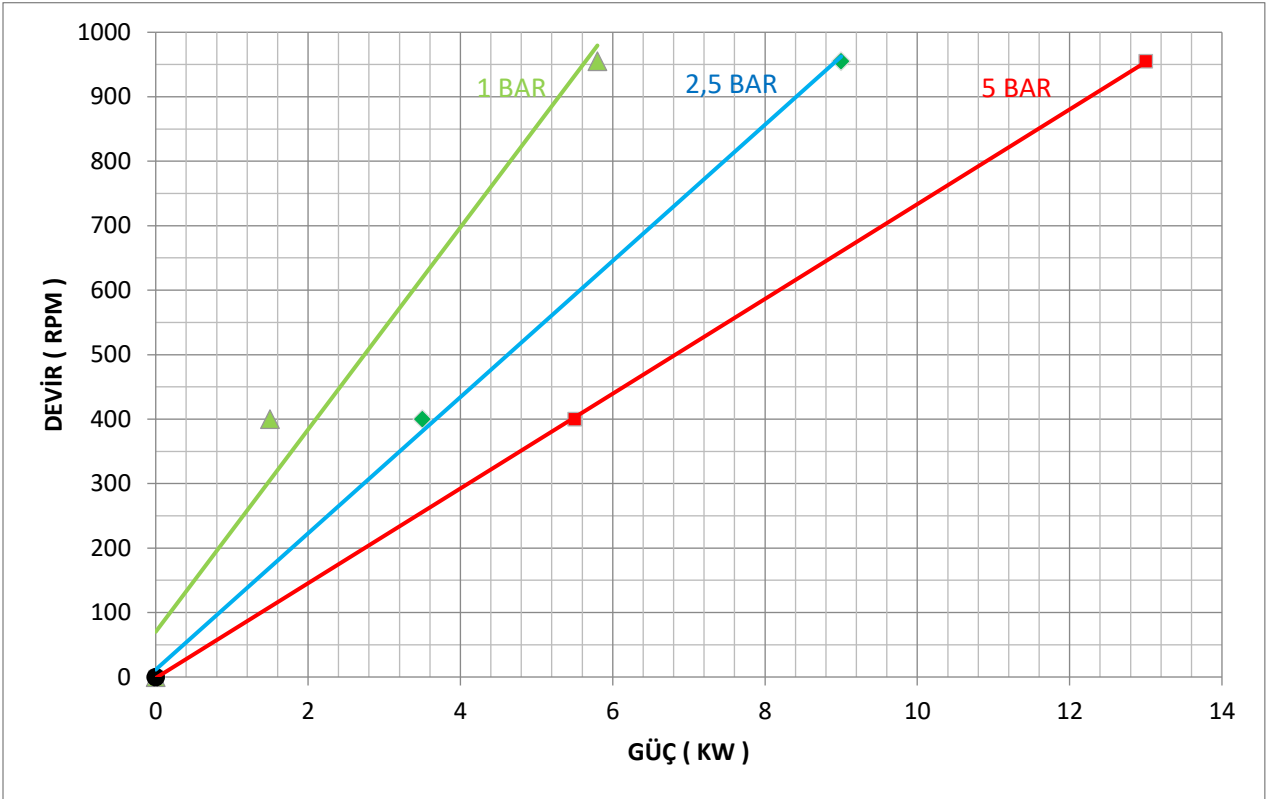

TESTLER SAE30 YAĞ İLE ODA SICAKLIĞINDA (YAKLAŞIK 100 CST) YAPILMIŞTIR.

## KHP3" HELİS DİŞLİ PERFORMANS EĞRİLERİ

### 1- Devir - Debi

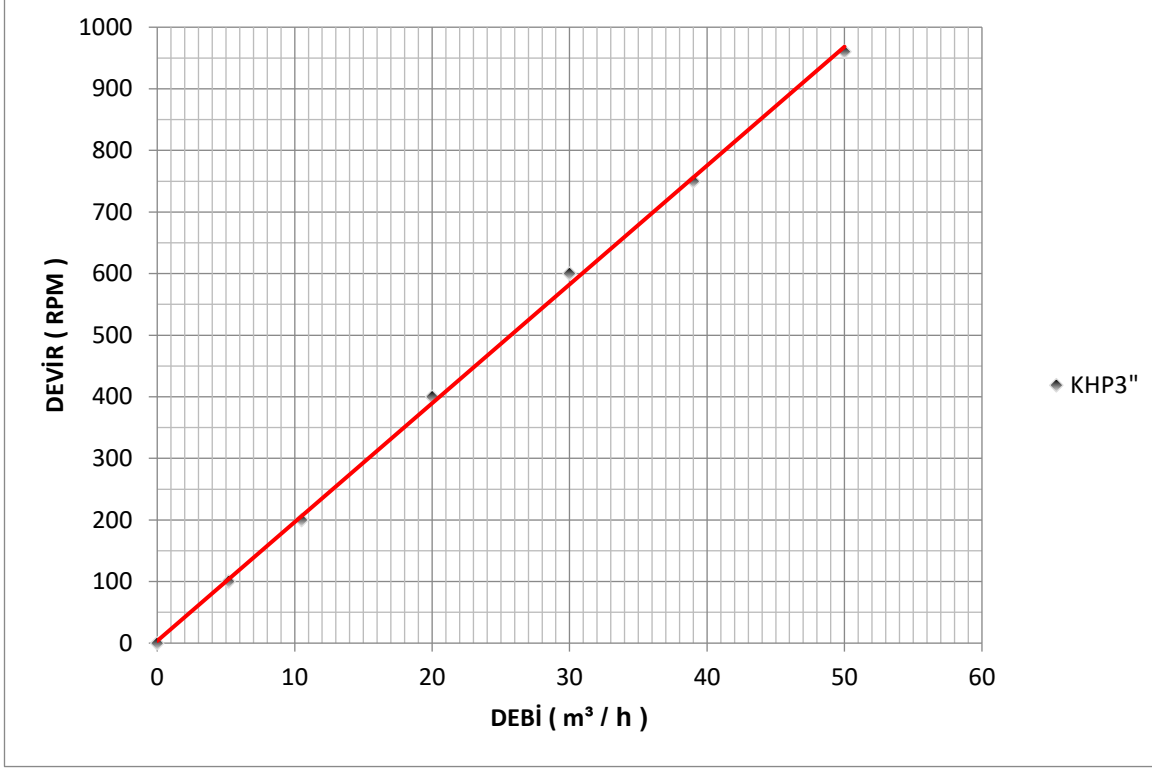

### 2- Devir - Güç - Basınç

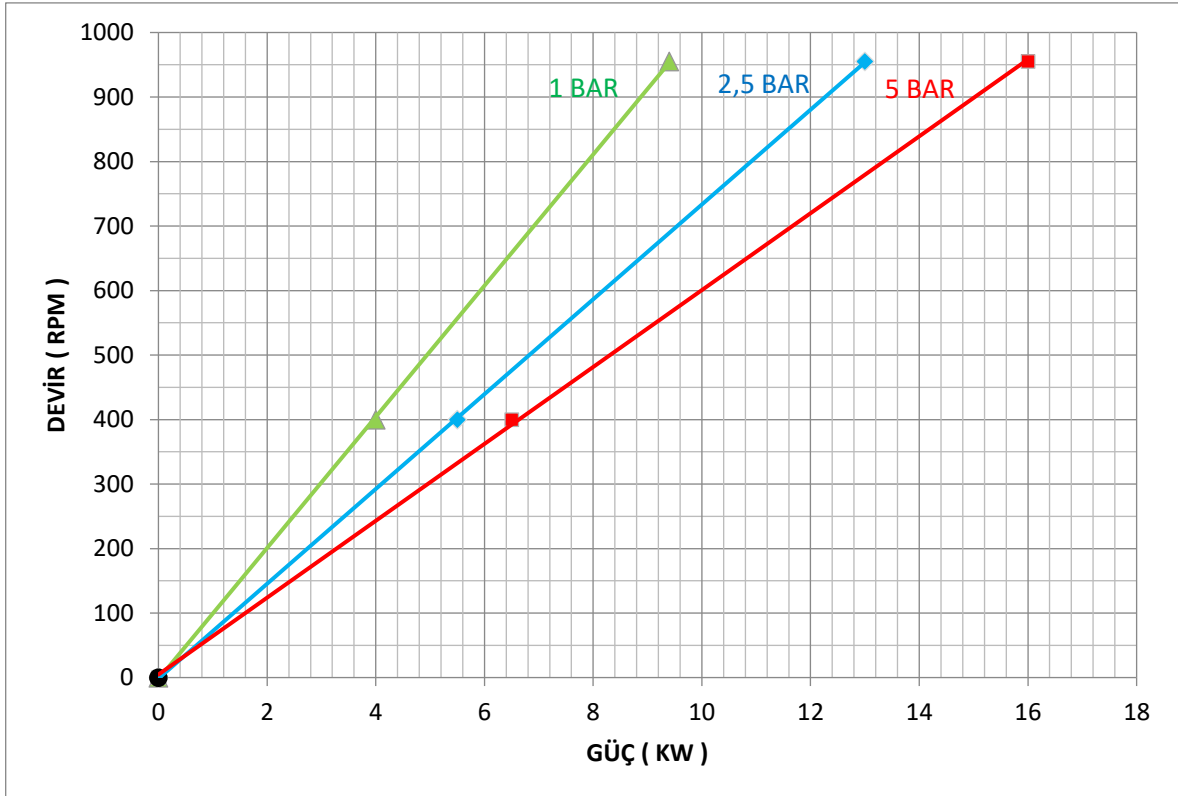

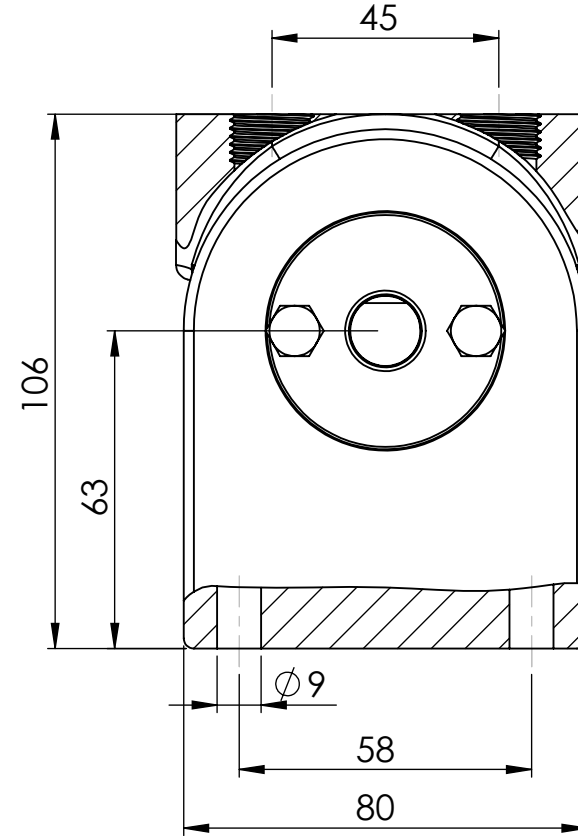
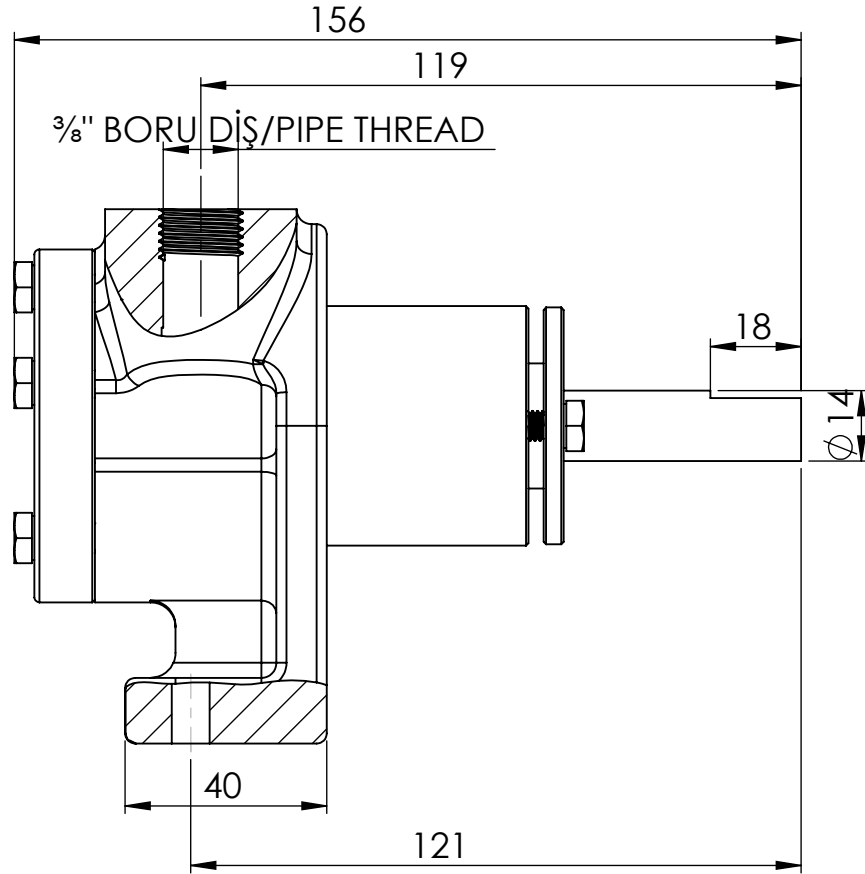

TESTLER SAE30 YAĞ İLE ODA SICAKLIĞINDA (YAKLAŞIK 100 CST) YAPILMIŞTIR.



	İSİM / NAME	NOTLAR / NOTES	PARÇA ADI / PART NAME:
ÇİZEN / DRAWN	VEDAT KARTAL	BU TEKNİK RESİMDEKİ TÜM BİLGİNİN MÜLKİYETİ KUCUKPARMAK MUH.SAN.TIC.LTD.ŞTİ AİTTİR. YAZILI İZİN OLMADAN, KİSMEN YADA TAMAMEN ÇOĞALTMALAR YAPMAK YASAKTIR.  ALL INFORMATION IN THIS TECHNICAL DRAWING PROPERTY KUCUKPARMAK MUH.SAN.TIC.LTD.ŞTİ IT BELONGS. WITHOUT WRITTEN PERMISSION, PARTIALLY OR COMPLETELY REPRODUCTIONS ARE PROHIBITED.	<b>KIPK<sup>3/8</sup>"</b> <b>İÇ DİŞLİ POMPA</b> <b>INTERNAL GEAR PUMP</b>
DENETLEYEN / CONTROLLED	HARUN POLAT		
ONAY / APPROVED	BAŞAR KÜÇÜKPARMAK		
REVİZYON TARİHİ / DATE OF REVISION	09.09.2021		

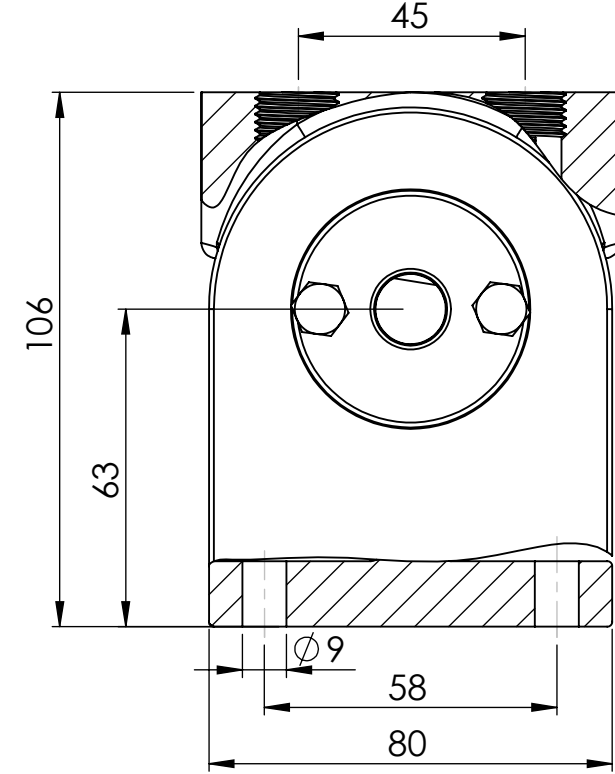
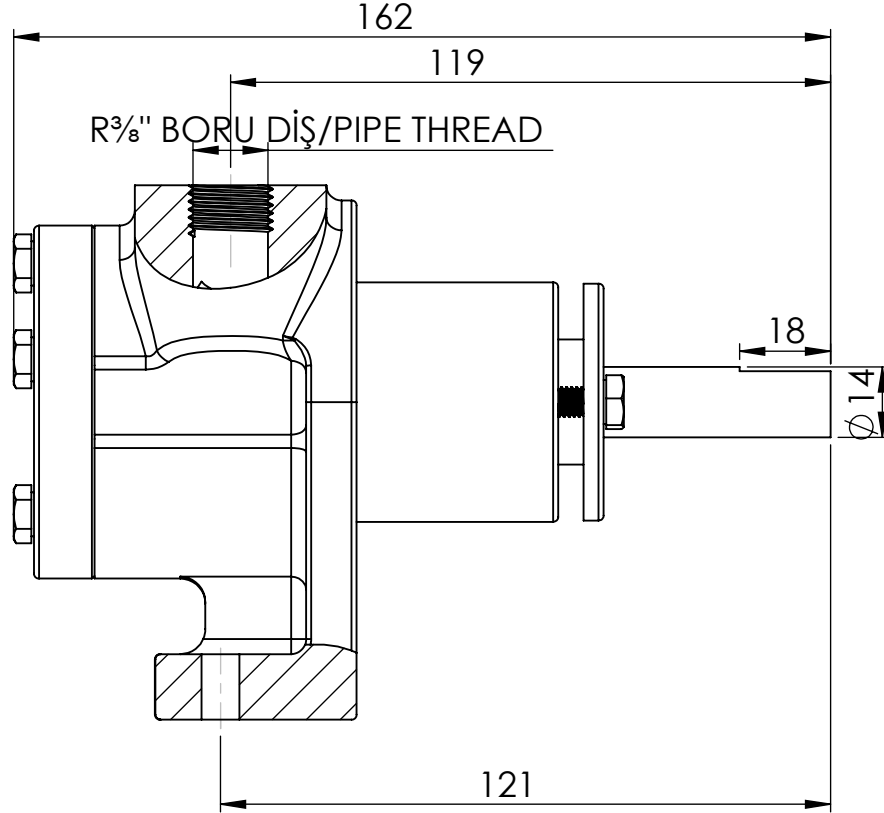



	İSİM / NAME	NOTLAR / NOTES	PARÇA ADI / PART NAME:	
ÇİZEN/ DRAWN	VEDAT KARTAL	BU TEKNİK RESİMDEKİ TÜM BİLGİNİN MÜLKİYETİ KUCUKPARMAK MUH.SAN.TIC.LTD.ŞTİ AİTTİR. YAZILI İZİN OLMADAN, KISMEN YADA TAMAMEN ÇOĞALTMALAR YAPMAK YASAKTIR. ALL INFORMATION IN THIS TECHNICAL DRAWING PROPERTY KUCUKPARMAK MUH.SAN.TIC.LTD.ŞTİ IT BELONGS. WITHOUT WRITTEN PERMISSION, PARTIALLY OR COMPLETELY REPRODUCTIONS ARE PROHIBITED.	<b>KIP<sup>3/8</sup>"</b> <b>İÇ DİŞLİ POMPA</b> <b>INTERNAL GEAR PUMP</b>	
DENETLEYEN / CONTROLLED	HARUN POLAT			
ONAY / APPROVED	BAŞAR KÜÇÜKPARMAK			
REVİZYON TARİHİ / DATE OF REVISION	09.09.2021			

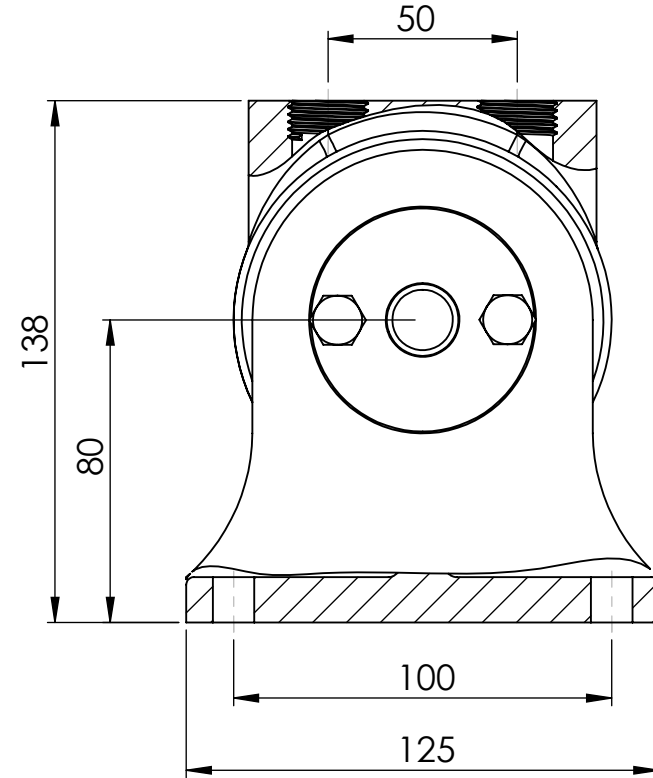
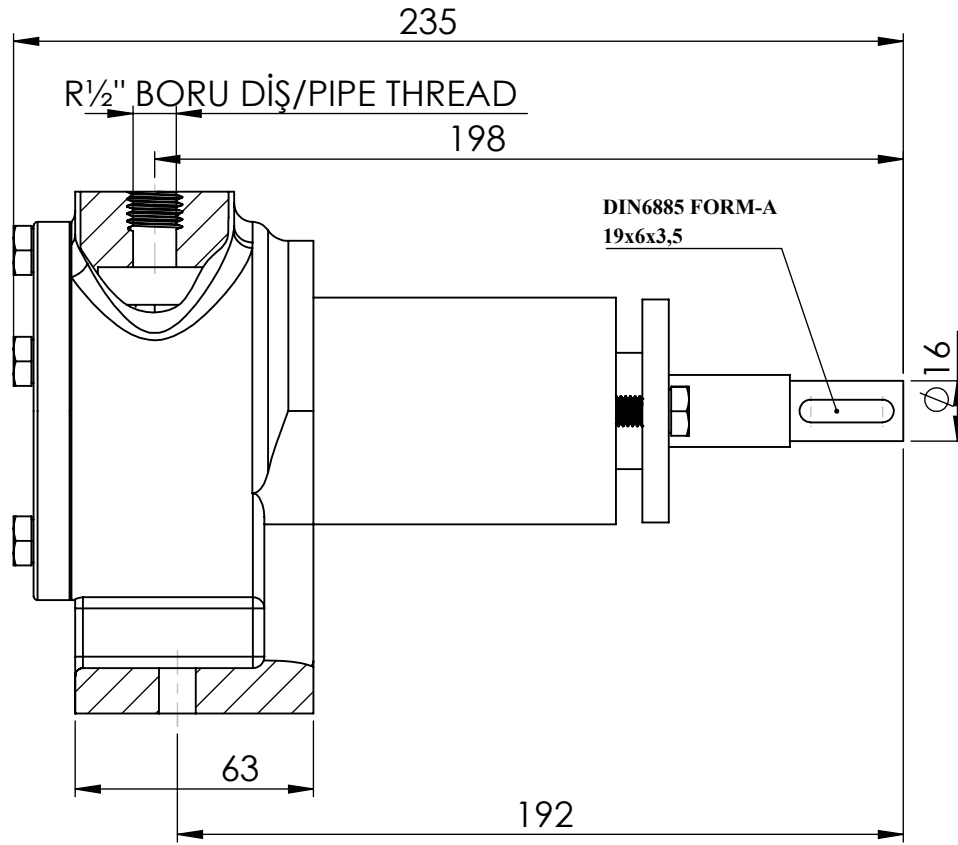

	İSİM / NAME	NOTLAR / NOTES	PARÇA ADI / PART NAME:
ÇİZEN / DRAWN	VEDAT KARTAL	BU TEKNİK RESİMDEKİ TÜM BİLGİNİN MÜLKİYETİ KUCUKPARMAK MUH.SAN.TIC.LTD.ŞTİ AİTTİR. YAZILI İZİN OLMADAN, KİSMEN YADA TAMAMEN ÇOĞALTMALAR YAPMAK YASAKTIR.  ALL INFORMATION IN THIS TECHNICAL DRAWING PROPERTY KUCUKPARMAK MUH.SAN.TIC.LTD.ŞTİ IT BELONGS. WITHOUT WRITTEN PERMISSION, PARTIALLY OR COMPLETELY REPRODUCTIONS ARE PROHIBITED.	<b>KIPK<math>\frac{1}{2}</math>"</b> <b>İÇ DİŞLİ POMPA</b> <b>INTERNAL GEAR PUMP</b>
DENETLEYEN / CONTROLLED	HARUN POLAT		
ONAY / APPROVED	BAŞAR KÜÇÜKPARMAK		
REVİZYON TARİHİ / DATE OF REVISION	09.09.2021		





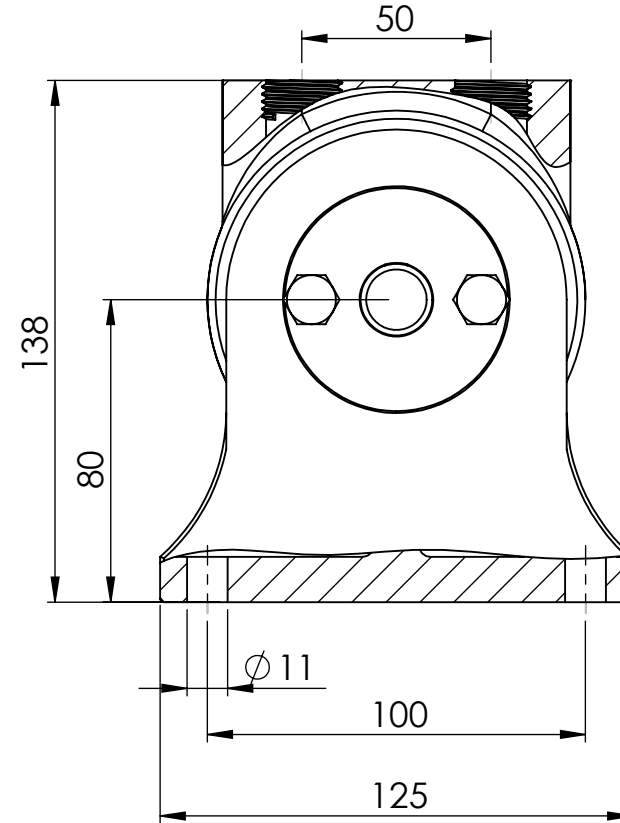
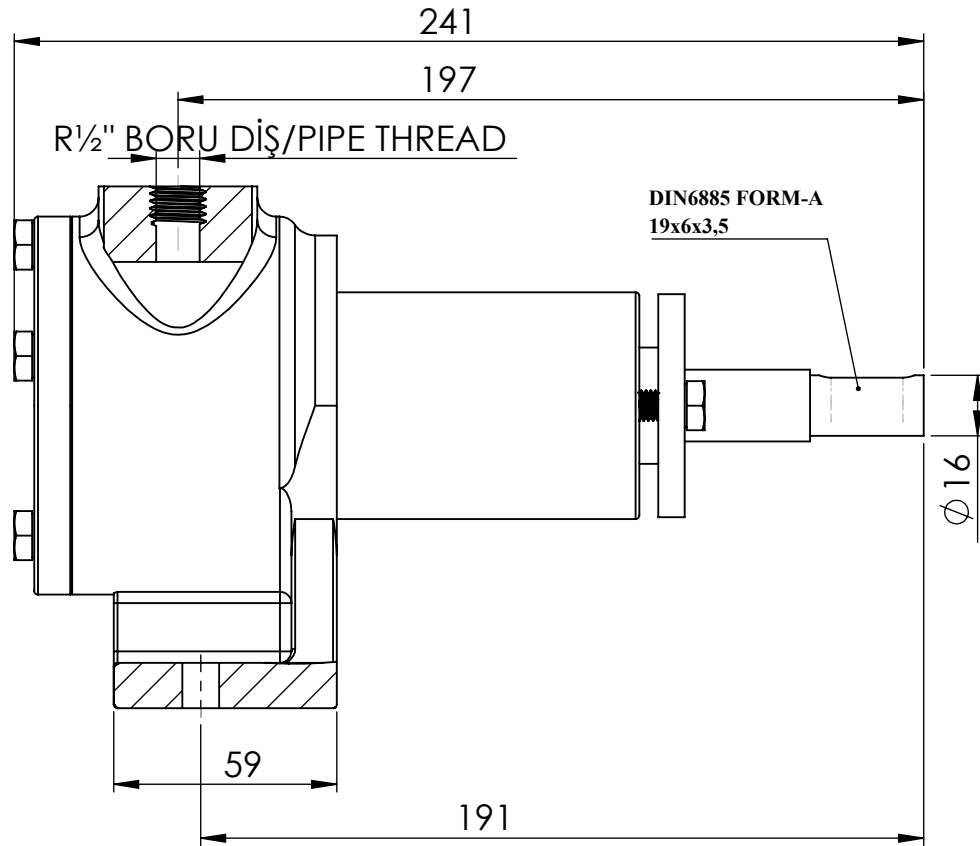

	İSİM / NAME	NOTLAR / NOTES	PARÇA ADI / PART NAME:
ÇİZEN / DRAWN	VEDAT KARTAL	BU TEKNİK RESİMDEKİ TÜM BİLGİNİN MÜLKİYETİ KUCUKPARMAK MUH.SAN.TIC.LTD.ŞTİ AİTTİR. YAZILI İZİN OLMADAN, KISMEN YADA TAMAMEN ÇOĞALTMALAR YAPMAK YASAKTIR.  ALL INFORMATION IN THIS TECHNICAL DRAWING PROPERTY KUCUKPARMAK MUH.SAN.TIC.LTD.ŞTİ IT BELONGS. WITHOUT WRITTEN PERMISSION, PARTIALLY OR COMPLETELY REPRODUCTIONS ARE PROHIBITED.	<b>KIP 1/2"</b> <b>İÇ DİŞLİ POMPA</b> <b>INTERNAL GEAR PUMP</b>
DENETLEYEN / CONTROLLED	HARUN POLAT		
ONAY / APPROVED	BAŞAR KÜÇÜKPARMAK		
REVİZYON TARİHİ / DATE OF REVISION	09.09.2021		



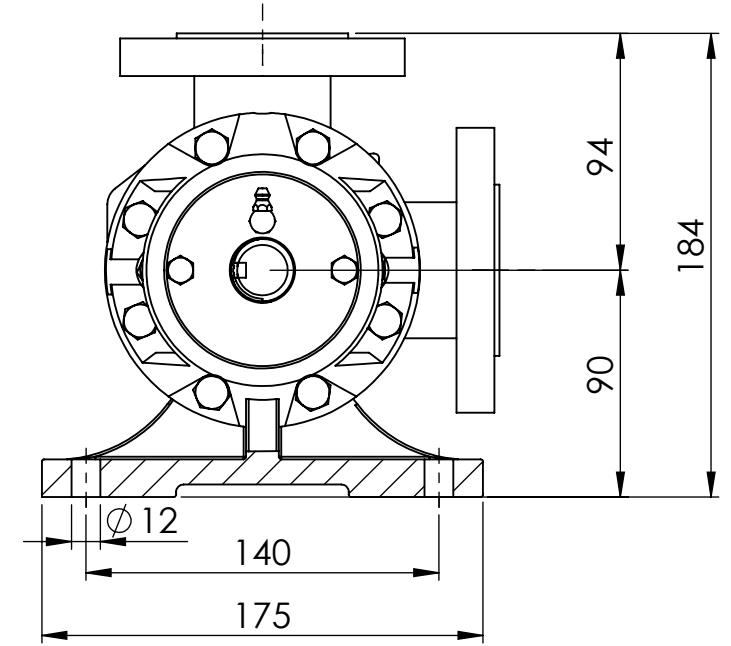
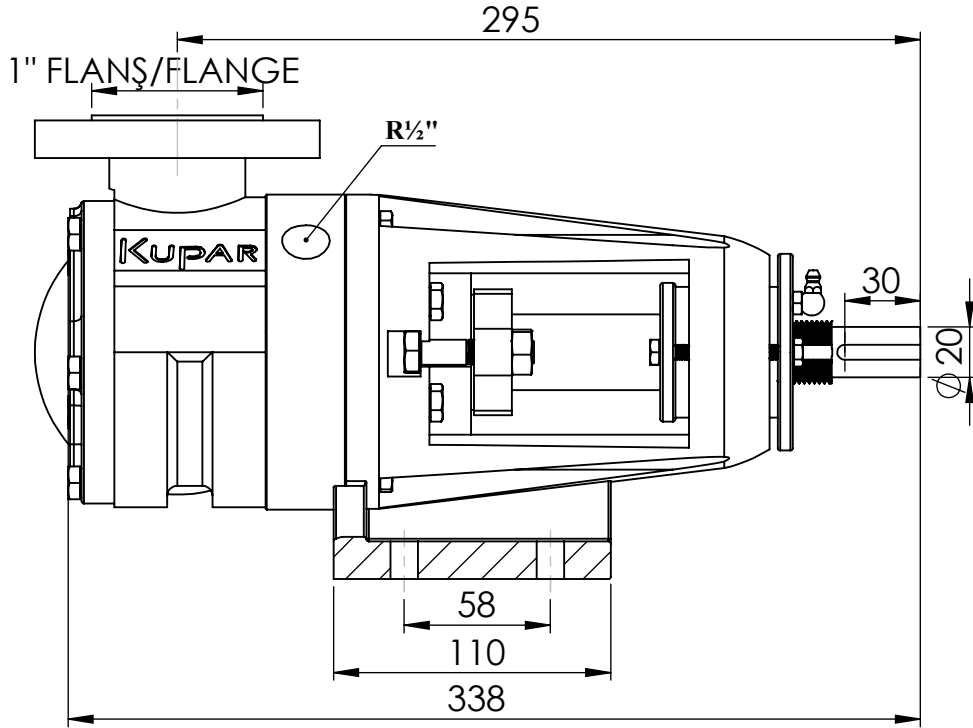

	İSİM / NAME	NOTLAR / NOTES
ÇİZEN/ DRAWN	VEDAT KARTAL	BU TEKNİK RESİMDEKİ TÜM BİLGİNİN MÜLKİYETİ KUCUKPARMAK MUH.SAN.TIC.LTD.ŞTİ AİTTİR. YAZILI İZİN OLMADAN, KISMEN YADA TAMAMEN ÇOĞALTMALAR YAPMAK YASAKTIR. ALL INFORMATION IN THIS TECHNICAL DRAWING PROPERTY KUCUKPARMAK MUH.SAN.TIC.LTD.ŞTİ IT BELONGS. WITHOUT WRITTEN PERMISSION, PARTIALLY OR COMPLETELY REPRODUCTIONS ARE PROHIBITED.
DENETLEYEN / CONTROLLED	HARUN POLAT	
ONAY / APPROVED	BAŞAR KÜÇÜKPARMAK	
REVİZYON TARİHİ / DATE OF REVISION	09.09.2022	

PARÇA ADI / PART NAME:

**KIP1"**  
**İÇ DİŞLİ POMPA**  
**INTERNAL GEAR PUMP**



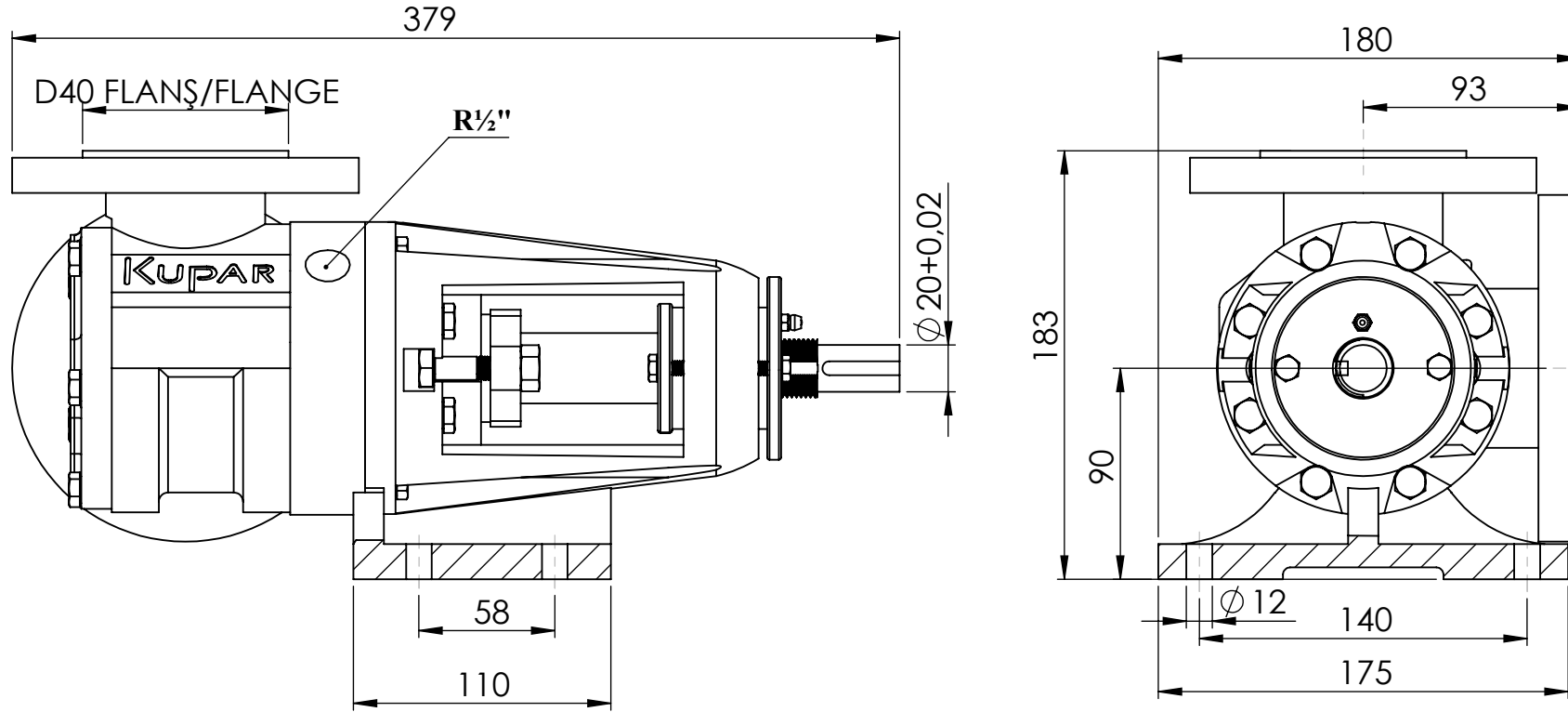

	İSİM / NAME	NOTLAR / NOTES	PARÇA ADI / PART NAME:
ÇİZEN / DRAWN	VEDAT KARTAL	BU TEKNİK RESİMDEKİ TÜM BİLGİNİN MÜLKİYETİ KUCUKPARMAK MUH.SAN.TIC.LTD.ŞTİ AİTTİR. YAZILI İZİN OLMADAN, KISMEN YADA TAMAMEN ÇOĞALTMALAR YAPMAK YASAKTIR.  ALL INFORMATION IN THIS TECHNICAL DRAWING PROPERTY KUCUKPARMAK MUH.SAN.TIC.LTD.ŞTİ IT BELONGS. WITHOUT WRITTEN PERMISSION, PARTIALLY OR COMPLETELY REPRODUCTIONS ARE PROHIBITED.	<b>KIPK1½"</b> <b>İÇ DİŞLİ POMPA</b> <b>INTERNAL GEAR PUMP</b>
DENETLEYEN / CONTROLLED	HARUN POLAT		
ONAY / APPROVED	BAŞAR KÜÇÜKPARMAK		
REVİZYON TARİHİ / DATE OF REVISION	09.09.2021		



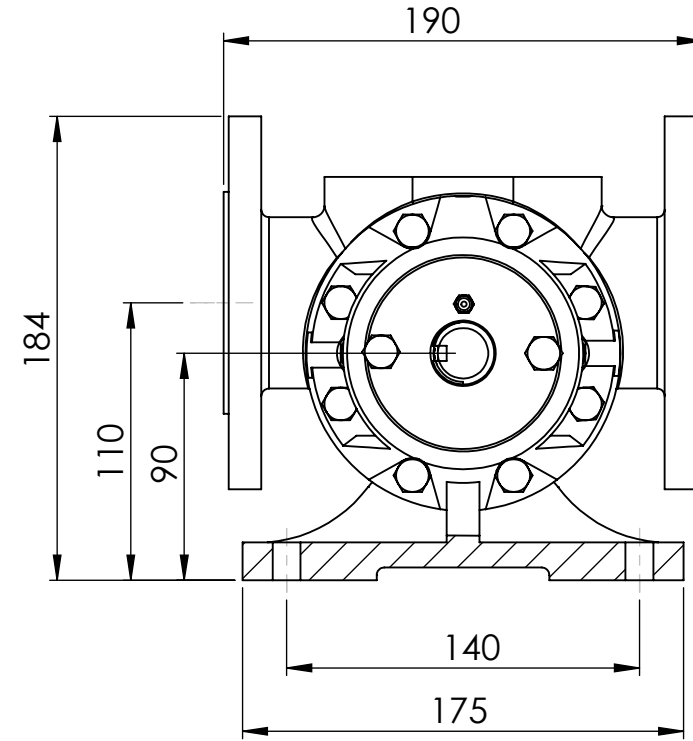
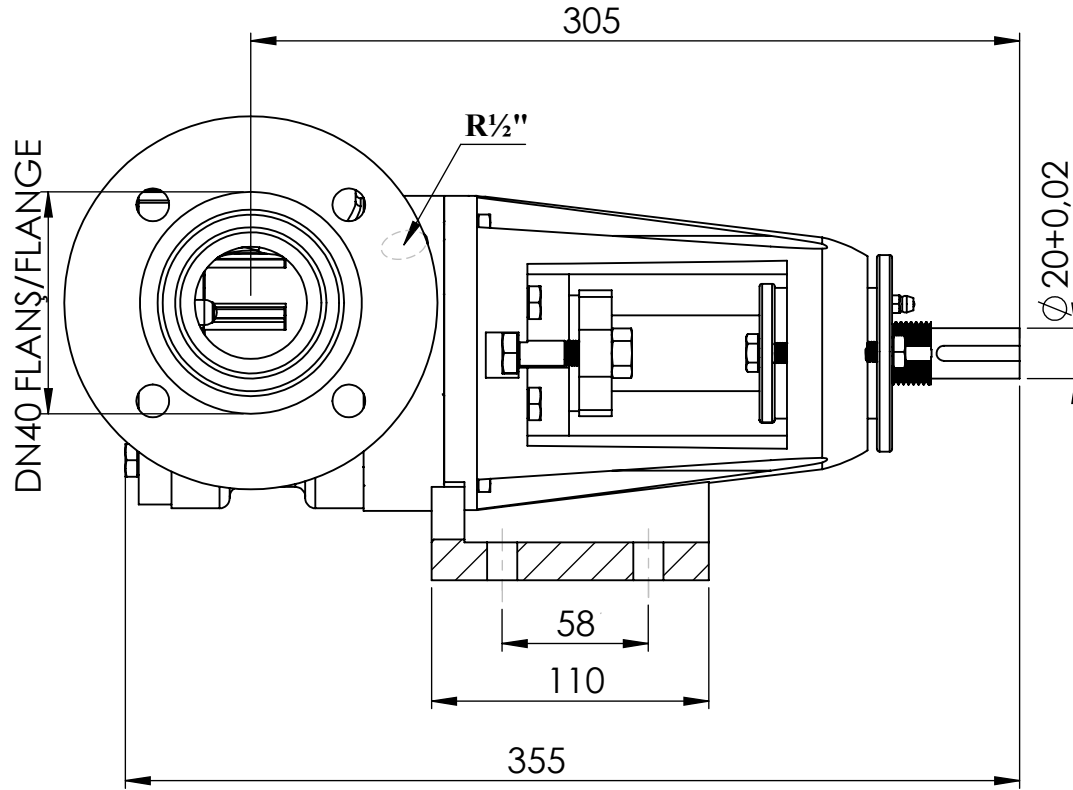

	İSİM / NAME	NOTLAR / NOTES
ÇİZEN / DRAWN	VEDAT KARTAL	BU TEKNİK RESİMDEKİ TÜM BİLGİNİN MÜLKİYETİ KUCUKPARMAK MUH.SAN.TIC.LTD.ŞTİ AİTTİR. YAZILI İZİN OLMADAN, KISMEN YADA TAMAMEN ÇOĞALTMALAR YAPMAK YASAKTIR. ALL INFORMATION IN THIS TECHNICAL DRAWING PROPERTY KUCUKPARMAK MUH.SAN.TIC.LTD.ŞTİ IT BELONGS. WITHOUT WRITTEN PERMISSION, PARTIALLY OR COMPLETELY REPRODUCTIONS ARE PROHIBITED.
DENETLEYEN / CONTROLLED	HARUN POLAT	
ONAY / APPROVED	BAŞAR KÜÇÜKPARMAK	
REVİZYON TARİHİ / DATE OF REVISION	10.05.2022	

PARÇA ADI / PART NAME:

**KIPK1½"-Y**  
**İÇ DİŞLİ POMPA**  
**INTERNAL GEAR PUMP**



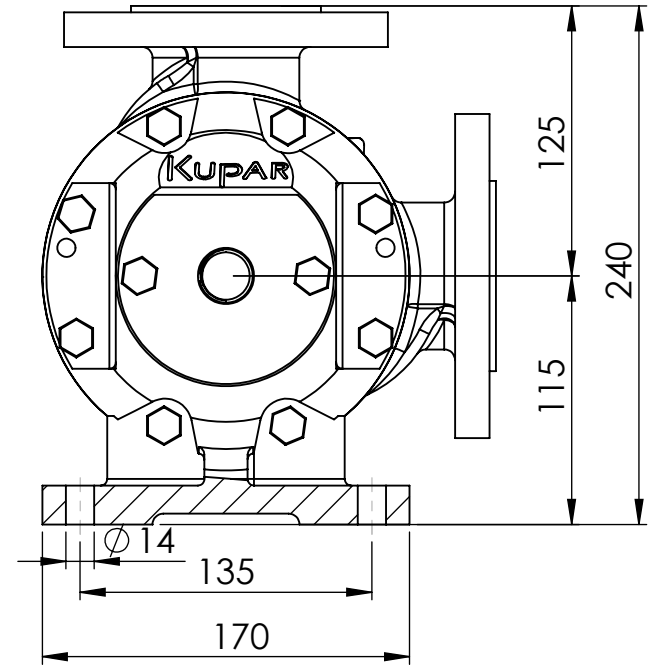
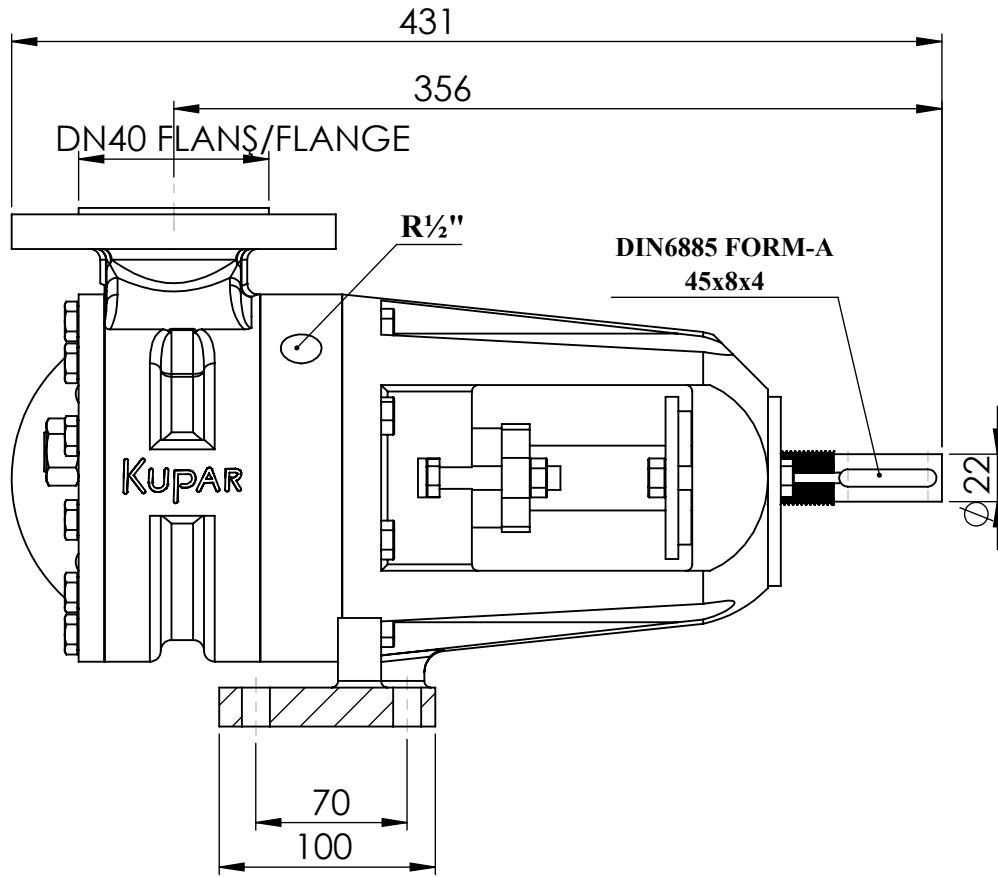

	İSİM / NAME	NOTLAR / NOTES	PARÇA ADI / PART NAME:
ÇİZEN / DRAWN	VEDAT KARTAL	BU TEKNİK RESİMDEKİ TÜM BİLGİNİN MÜLKİYETİ KUCUKPARMAK MUH.SAN.TIC.LTD.ŞTİ AİTTİR. YAZILI İZİN OLMADAN, KISMEN YADA TAMAMEN ÇOĞALTMALAR YAPMAK YASAKTIR.  ALL INFORMATION IN THIS TECHNICAL DRAWING PROPERTY KUCUKPARMAK MUH.SAN.TIC.LTD.ŞTİ IT BELONGS. WITHOUT WRITTEN PERMISSION, PARTIALLY OR COMPLETELY REPRODUCTIONS ARE PROHIBITED.	<b>KIP1½"</b> <b>İÇ DİŞLİ POMPA</b> <b>INTERNAL GEAR PUMP</b>
DENETLEYEN / CONTROLLED	HARUN POLAT		
ONAY / APPROVED	BAŞAR KÜÇÜKPARMAK		
REVİZYON TARİHİ / DATE OF REVISION	09.09.2021		



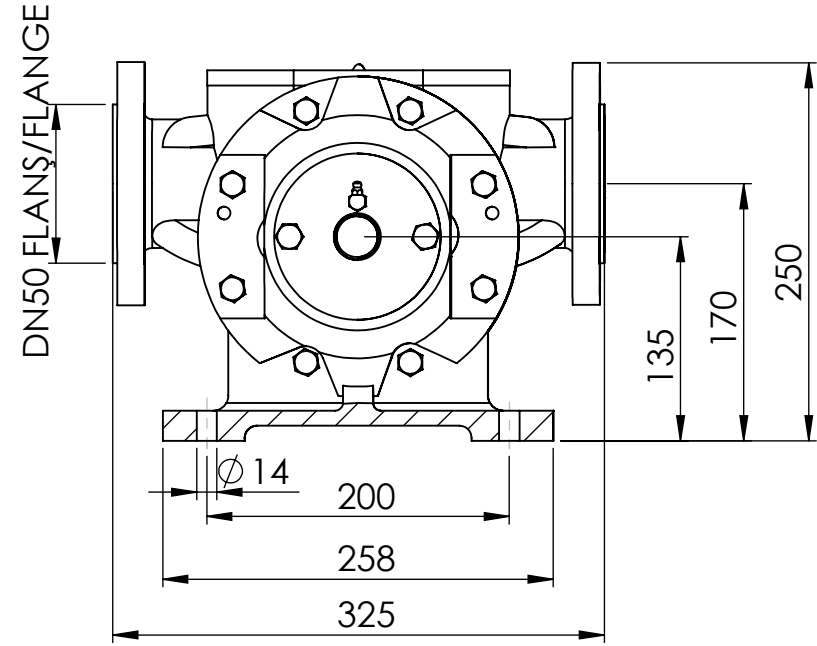
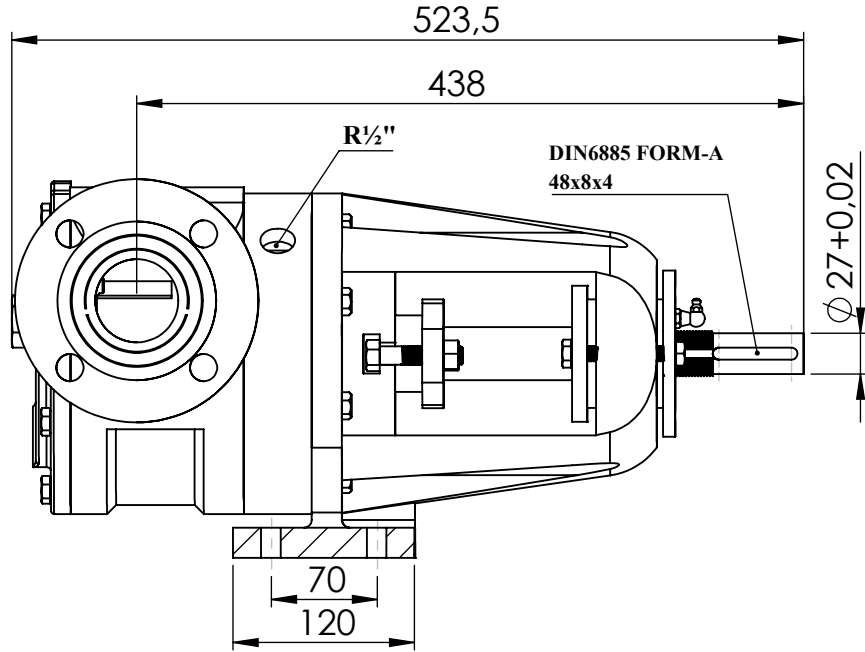



	İSİM / NAME	NOTLAR / NOTES
ÇİZEN / DRAWN	VEDAT KARTAL	BU TEKNİK RESİMDEKİ TÜM BİLGİNİN MÜLKİYETİ KUCUKPARMAK MUH.SAN.TIC.LTD.ŞTİ AİTTİR. YAZILI İZİN OLMADAN, KISMEN YADA TAMAMEN ÇOĞALTMALAR YAPMAK YASAKTIR. ALL INFORMATION IN THIS TECHNICAL DRAWING PROPERTY KUCUKPARMAK MUH.SAN.TIC.LTD.ŞTİ IT BELONGS. WITHOUT WRITTEN PERMISSION, PARTIALLY OR COMPLETELY REPRODUCTIONS ARE PROHIBITED.
DENETLEYEN / CONTROLLED	HARUN POLAT	
ONAY / APPROVED	BAŞAR KÜÇÜKPARMAK	
REVİZYON TARİHİ / DATE OF REVISION	10.05.2022	

PARÇA ADI / PART NAME:

**KIP2"-Y**  
**İÇ DİŞLİ POMPA**  
**INTERNAL GEAR PUMP**

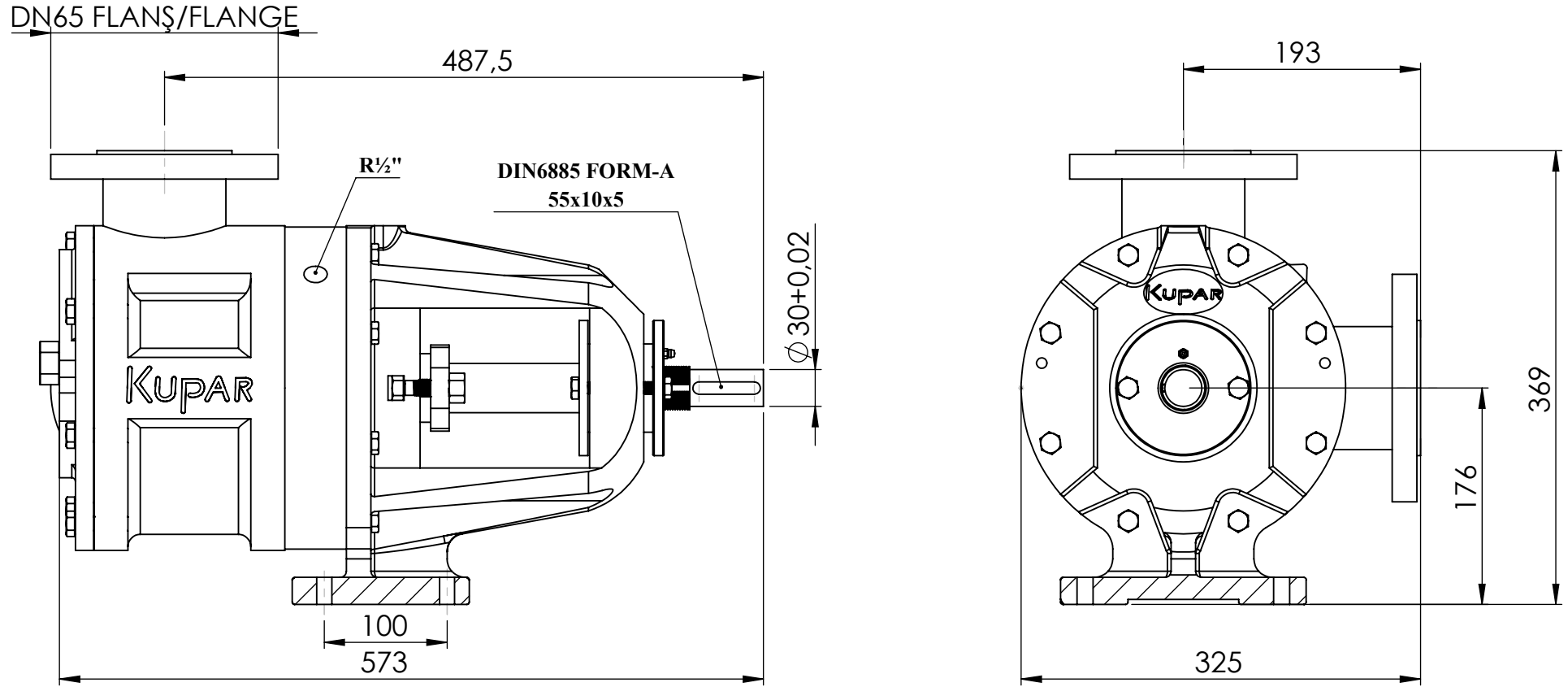



	İSİM / NAME	NOTLAR / NOTES	PARÇA ADI / PART NAME:
ÇİZEN/ DRAWN	VEDAT KARTAL	BU TEKNİK RESİMDEKİ TÜM BİLGİNİN MÜLKİYETİ KUCUKPARMAK MUH.SAN.TIC.LTD.ŞTİ AİTTİR. YAZILI İZİN OLMADAN, KISMEN YADA TAMAMEN ÇOGALTMALAR YAPMAK YASAKTIR.  ALL INFORMATION IN THIS TECHNICAL DRAWING PROPERTY KUCUKPARMAK MUH.SAN.TIC.LTD.ŞTİ IT BELONGS. WITHOUT WRITTEN PERMISSION, PARTIALLY OR COMPLETELY REPRODUCTIONS ARE PROHIBITED.	<b>KIP2½"</b> <b>İÇ DİŞLİ POMPA</b> <b>INTERNAL GEAR PUMP</b>
DENETLEYEN / CONTROLLED	HARUN POLAT		
ONAY / APPROVED	BAŞAR KÜÇÜKPARMAK		
REVİZYON TARİHİ / DATE OF REVISION	11.05.2022		

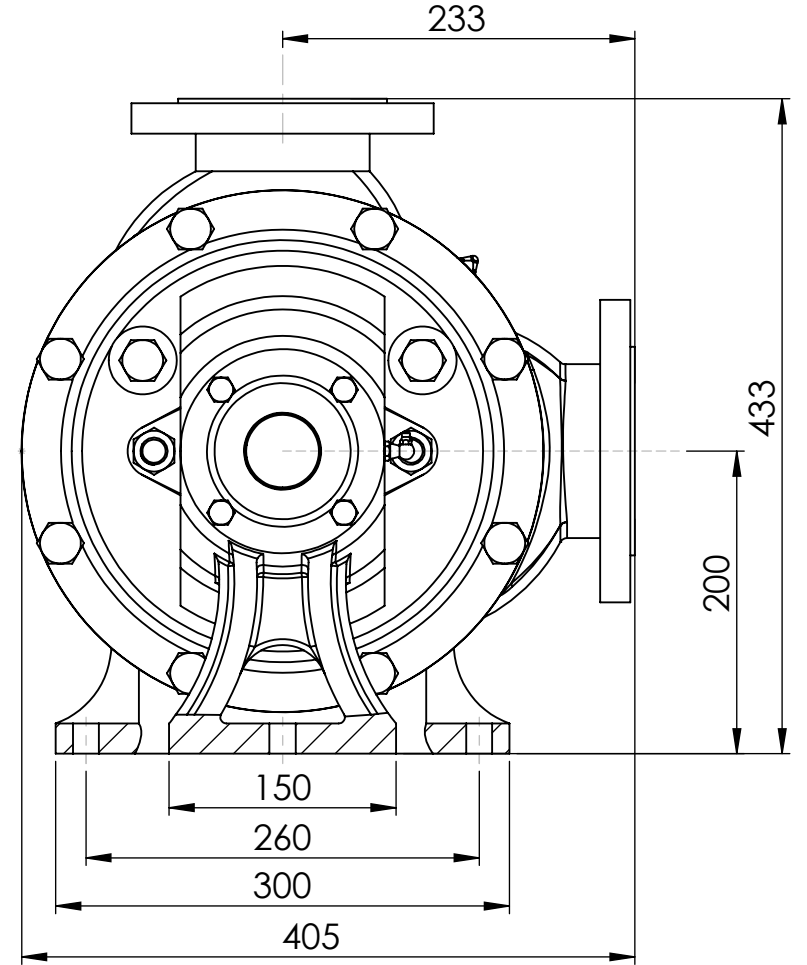
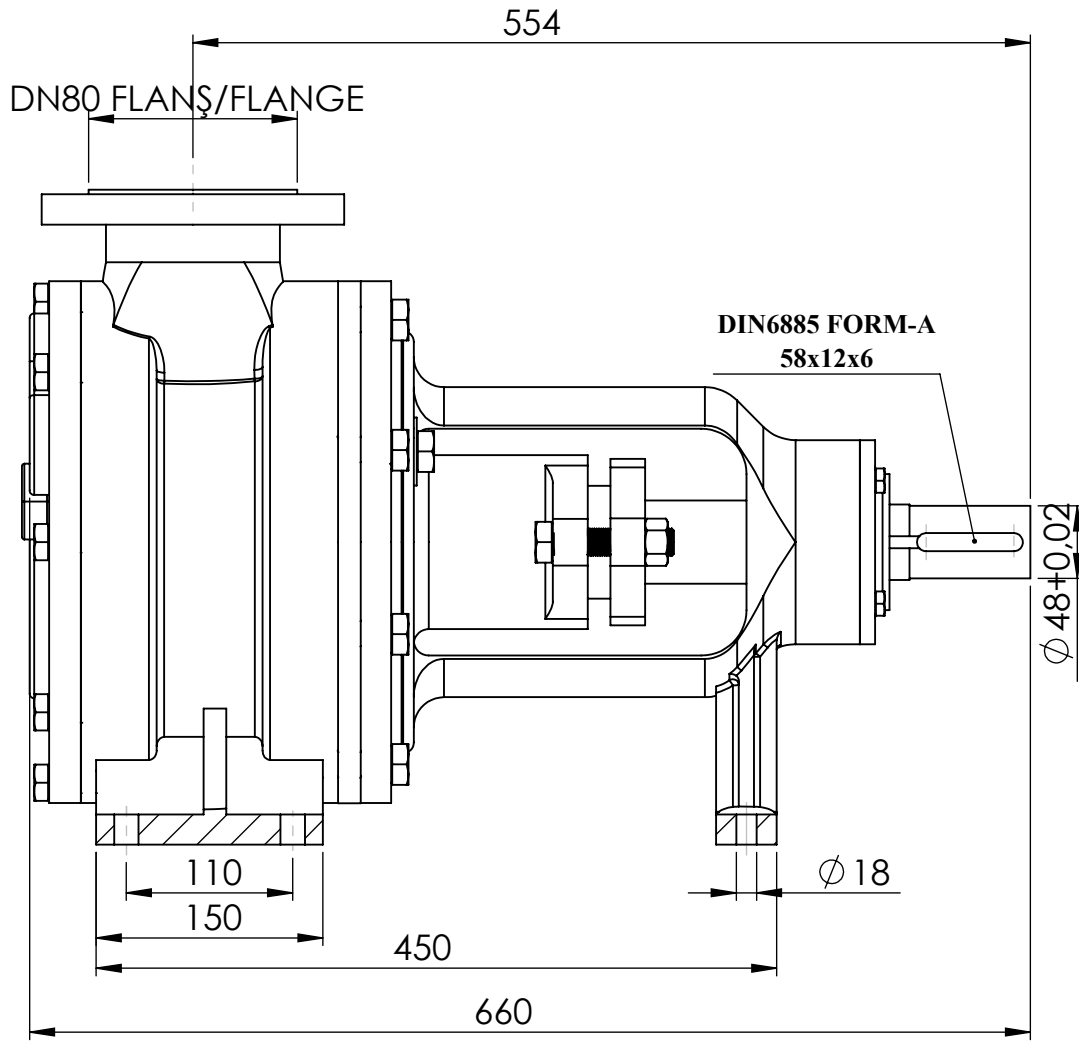

	İSİM / NAME	NOTLAR / NOTES	PARÇA ADI / PART NAME:
ÇİZEN / DRAWN	VEDAT KARTAL	BU TEKNİK RESİMDEKİ TÜM BİLGİNİN MÜLKİYETİ KUCUKPARMAK MUH.SAN.TIC.LTD.ŞTİ AİTTİR. YAZILI İZİN OLMADAN, KISMEN YADA TAMAMEN ÇOĞALTMALAR YAPMAK YASAKTIR. ALL INFORMATION IN THIS TECHNICAL DRAWING PROPERTY KUCUKPARMAK MUH.SAN.TIC.LTD.ŞTİ IT BELONGS. WITHOUT WRITTEN PERMISSION, PARTIALLY OR COMPLETELY REPRODUCTIONS ARE PROHIBITED.	<b>KIP3"</b> <b>İÇ DİŞLİ POMPA</b> <b>INTERNAL GEAR PUMP</b>
DENETLEYEN / CONTROLLED	HARUN POLAT		
ONAY / APPROVED	BAŞAR KÜÇÜKPARMAK		
REVİZYON TARİHİ / DATE OF REVISION	11.05.2022		





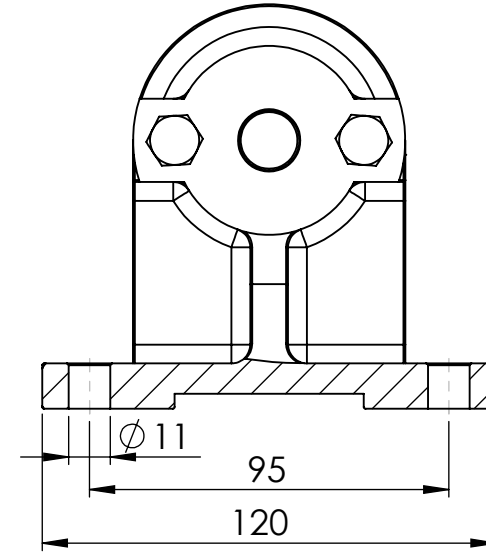
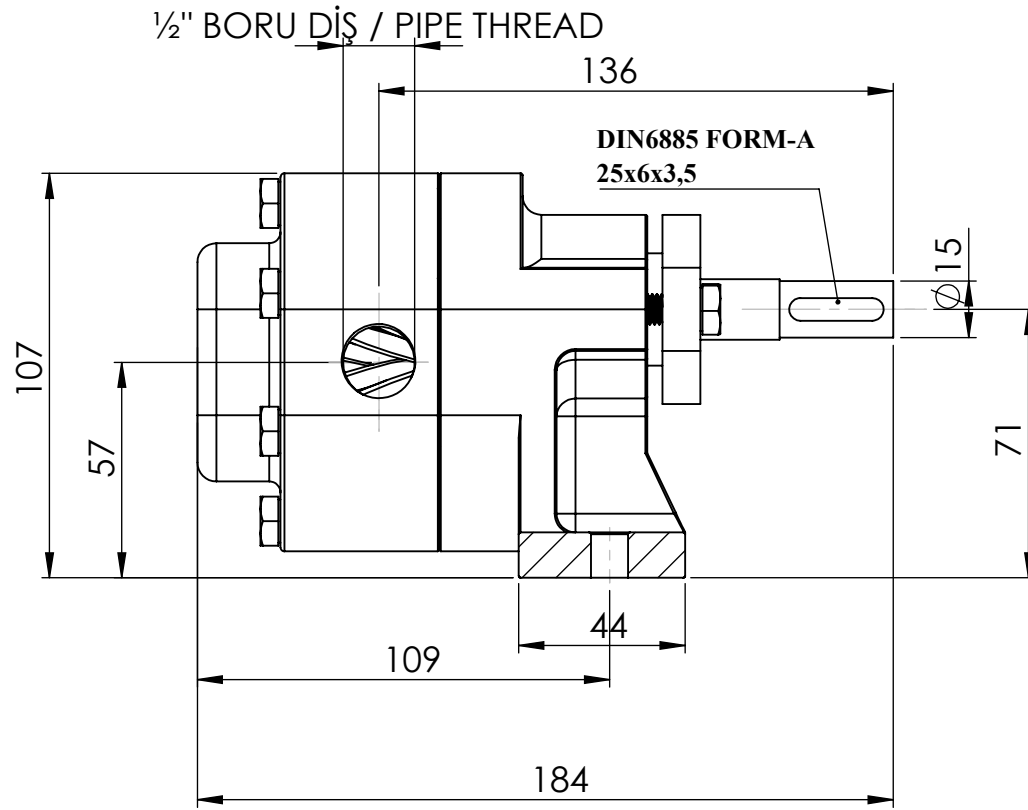

	İSİM / NAME	NOTLAR / NOTES	PARÇA ADI / PART NAME:
ÇİZEN/ DRAWN	VEDAT KARTAL		<b>KHP1/2"</b> <b>HELİS DİŞLİ POMPA</b> <b>HELICAL GEAR PUMP</b>
DENETLEYEN / CONTROLLED	HARUN POLAT		
ONAY / APPROVED	BAŞAR KÜÇÜKPARMAK		
REVİZYON TARİHİ / DATE OF REVISION	11.04.2022		



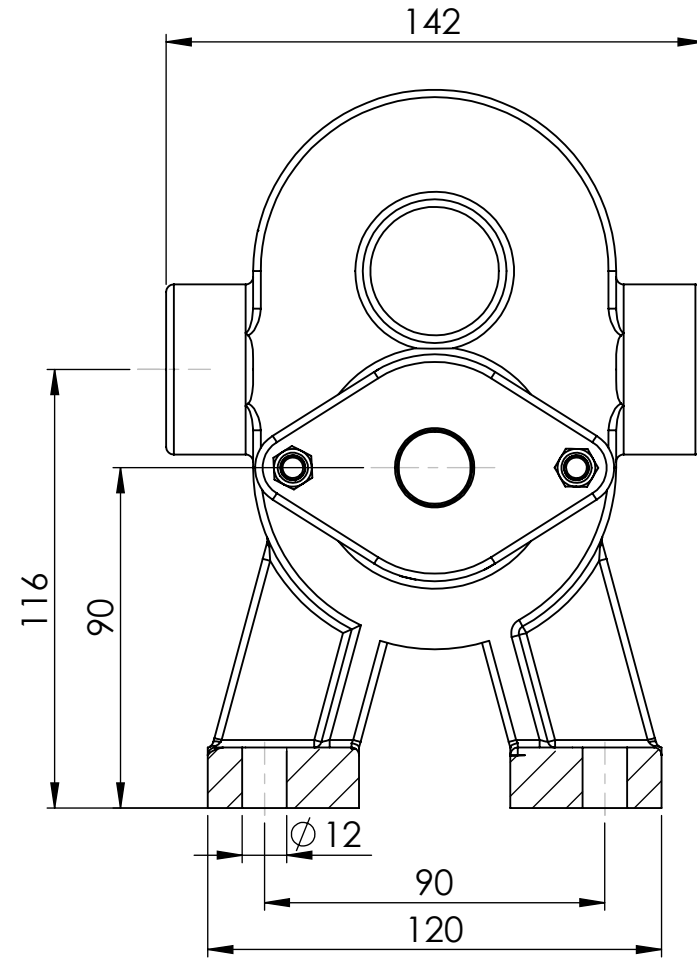
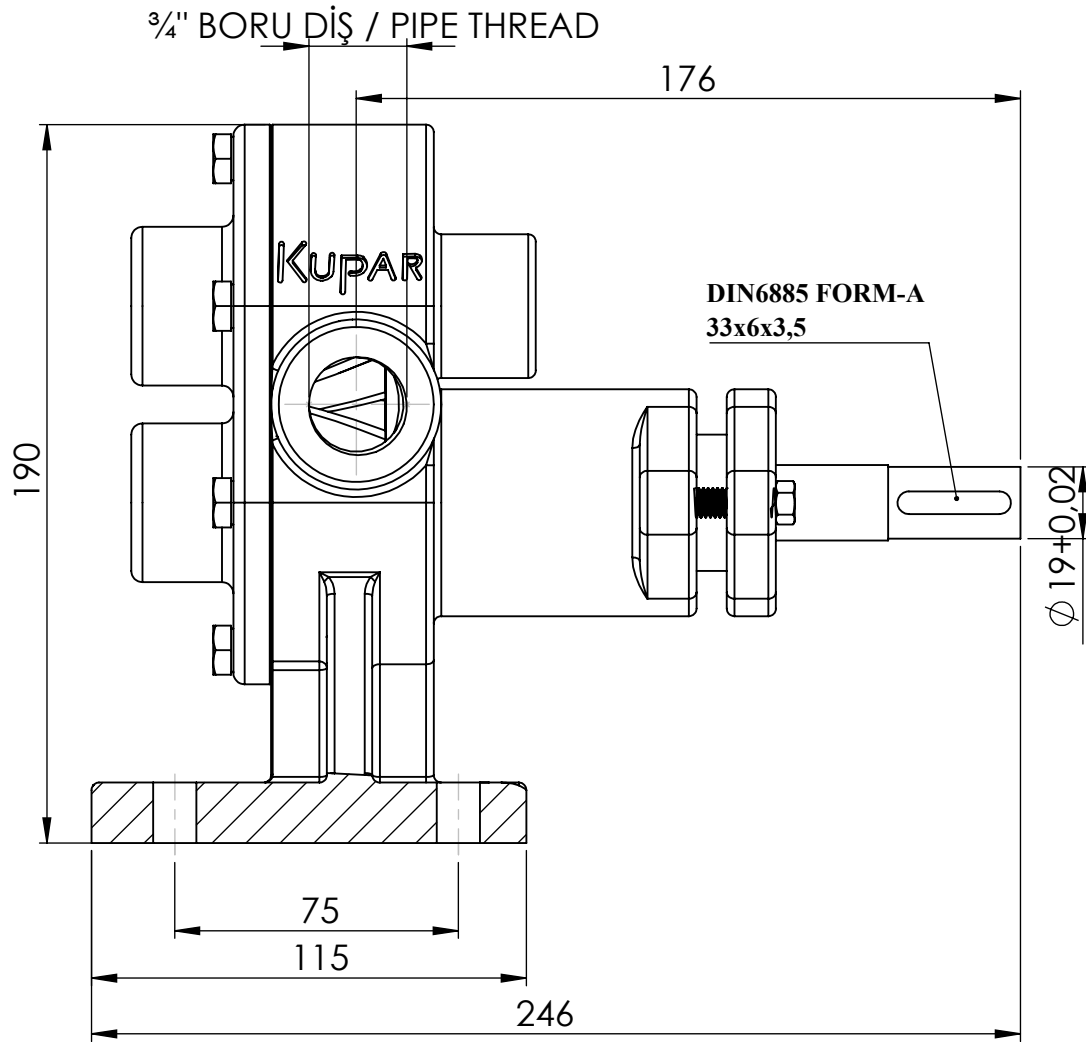

	İSİM / NAME	NOTLAR / NOTES	PARÇA ADI / PART NAME:
ÇİZEN / DRAWN	VEDAT KARTAL		<b>KHP<sup>3/4"</sup></b> <b>HELİS DİŞLİ POMPA</b> <b>HELICAL GEAR PUMP</b>
DENETLEYEN / CONTROLLED	HARUN POLAT		
ONAY / APPROVED	BAŞAR KÜÇÜKPARMAK		
REVİZYON TARİHİ / DATE OF REVISION	11.04.2022		



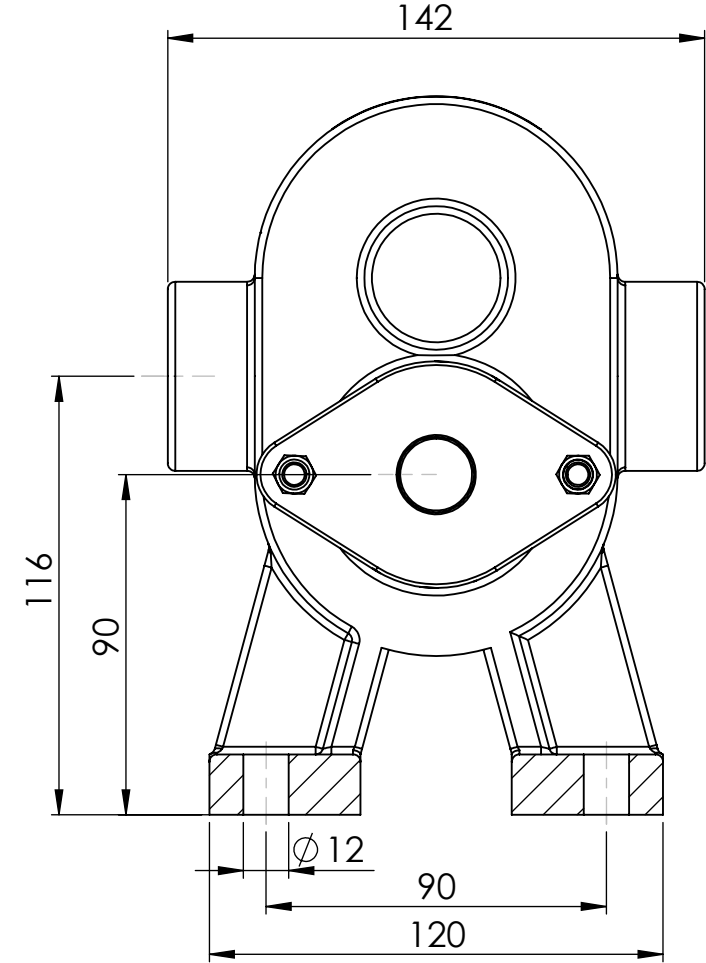
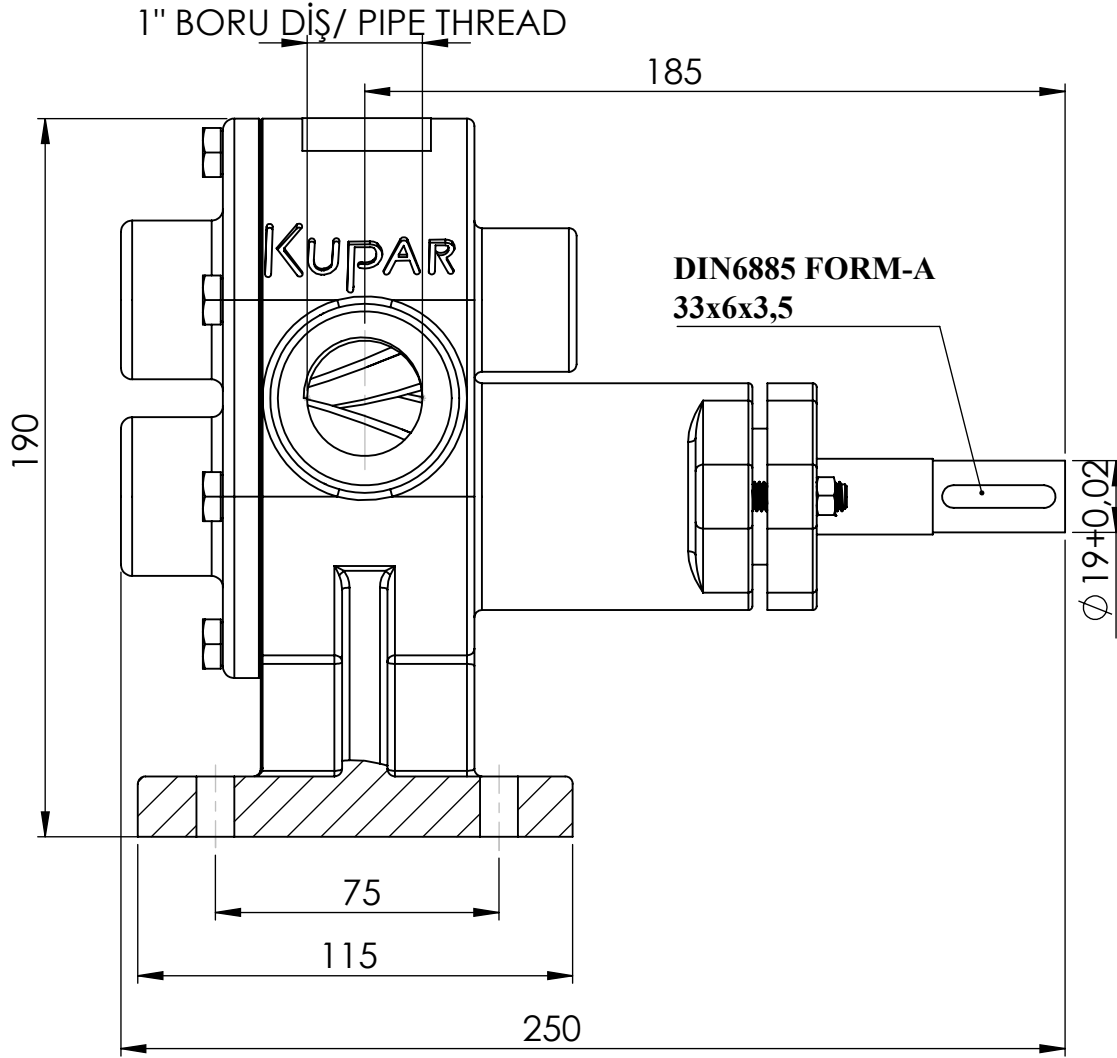

	İSİM / NAME	NOTLAR / NOTES	PARÇA ADI / PART NAME:
ÇİZEN / DRAWN	VEDAT KARTAL		<b>KHP1"</b> <b>HELİS DİŞLİ POMPA</b> <b>HELICAL GEAR PUMP</b>
DENETLEYEN / CONTROLLED	HARUN POLAT		
ONAY / APPROVED	BAŞAR KÜÇÜKPARMAK		
REVİZYON TARİHİ / DATE OF REVISION	11.04.2022		



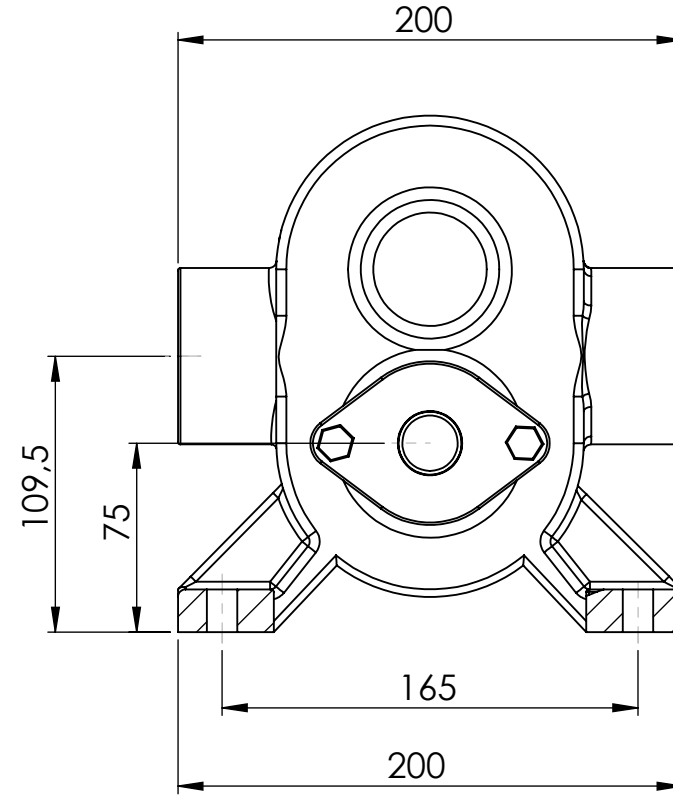
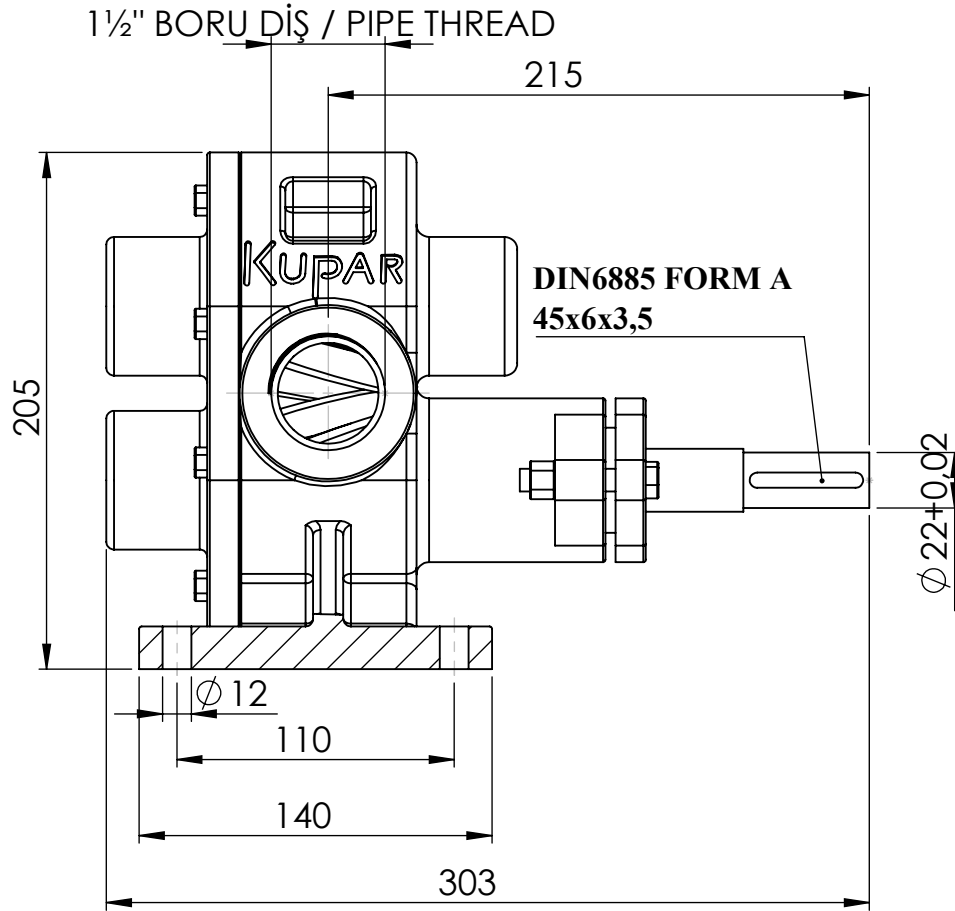

	İSİM / NAME	NOTLAR / NOTES	PARÇA ADI / PART NAME:
ÇİZEN / DRAWN	VEDAT KARTAL		<b>KHP1 1/2"</b> <b>HELİS DİŞLİ POMPA</b> <b>HELICAL GEAR PUMP</b>
DENETLEYEN / CONTROLLED	HARUN POLAT		
ONAY / APPROVED	BAŞAR KÜÇÜKPARMAK		
REVİZYON TARİHİ / DATE OF REVISION	11.01.2022		



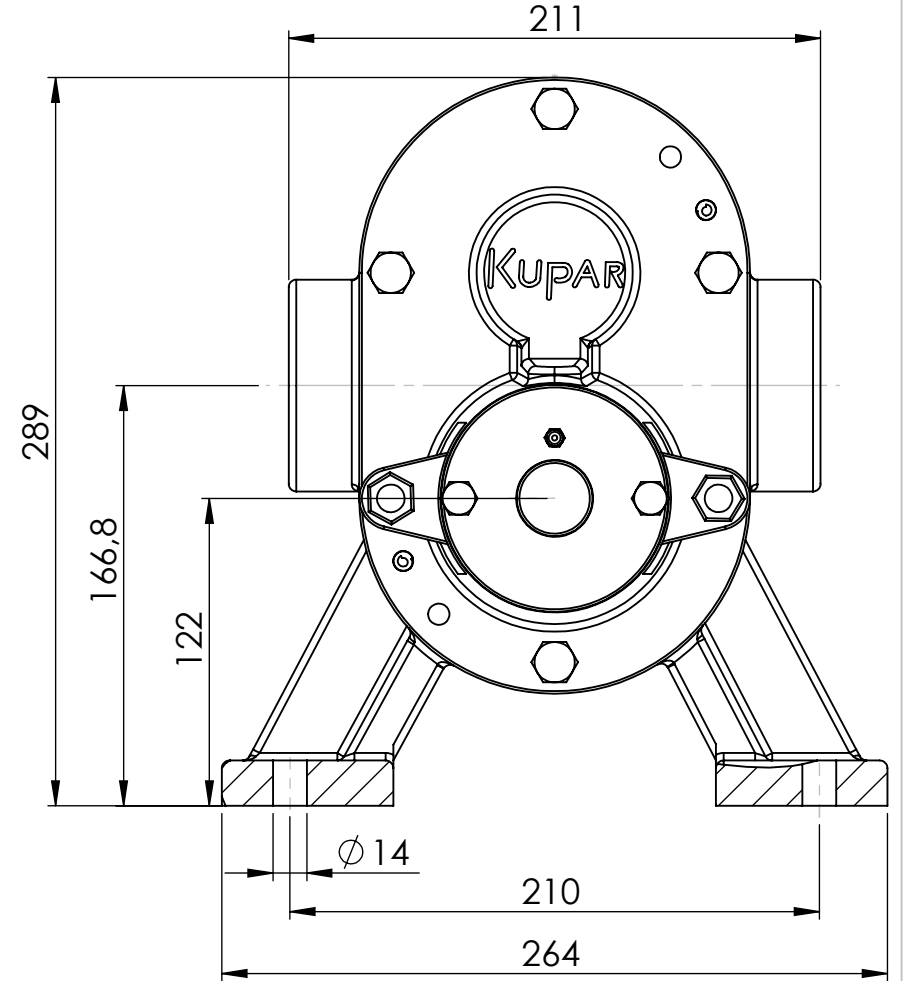
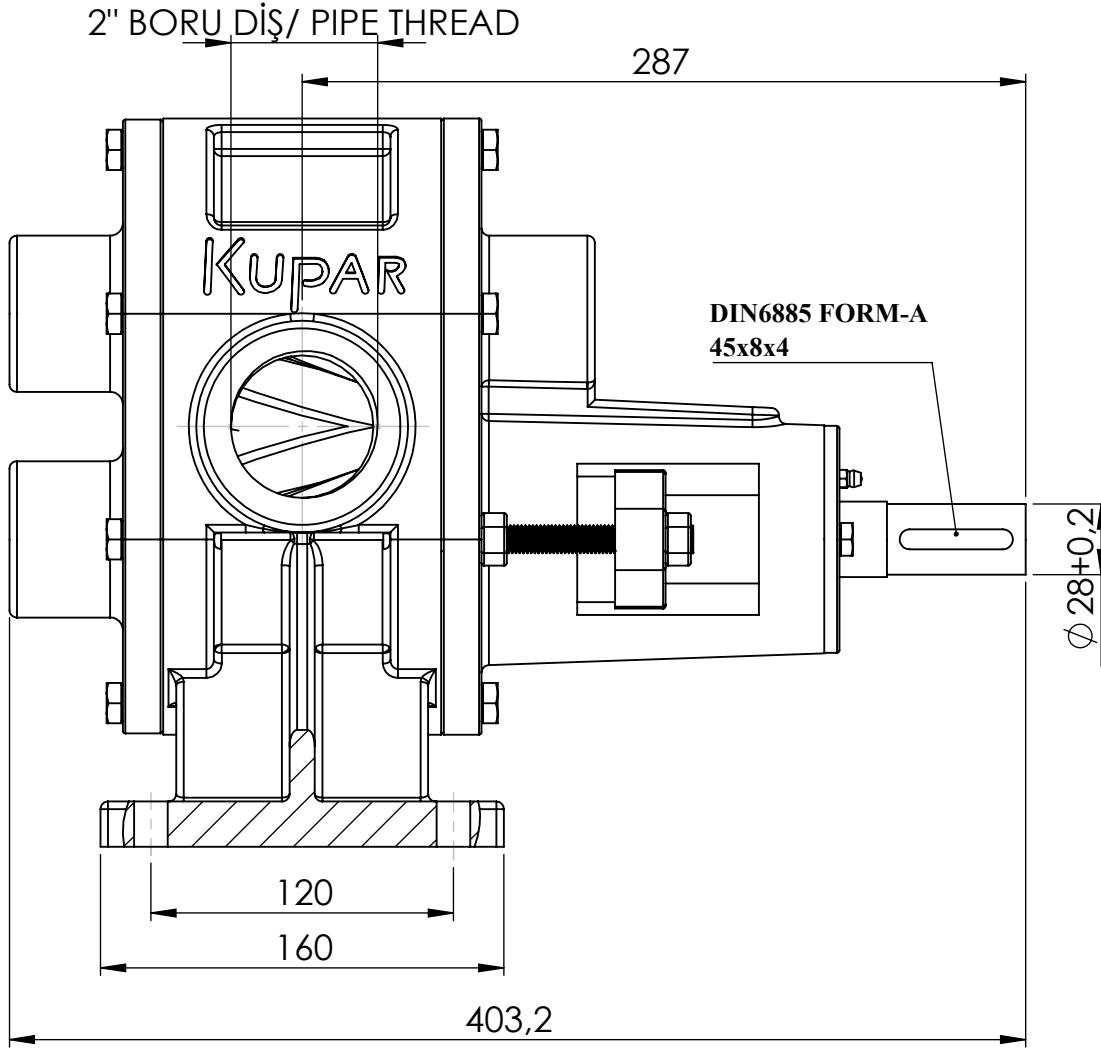

	İSİM / NAME	NOTLAR / NOTES	PARÇA ADI / PART NAME:
ÇİZEN / DRAWN	VEDAT KARTAL		<b>KHP2"</b> <b>HELİS DİŞLİ POMPA</b> <b>HELICAL GEAR PUMP</b>
DENETLEYEN / CONTROLLED	HARUN POLAT		
ONAY / APPROVED	BAŞAR KÜÇÜKPARMAK		
REVİZYON TARİHİ / DATE OF REVISION	04.04.2022		



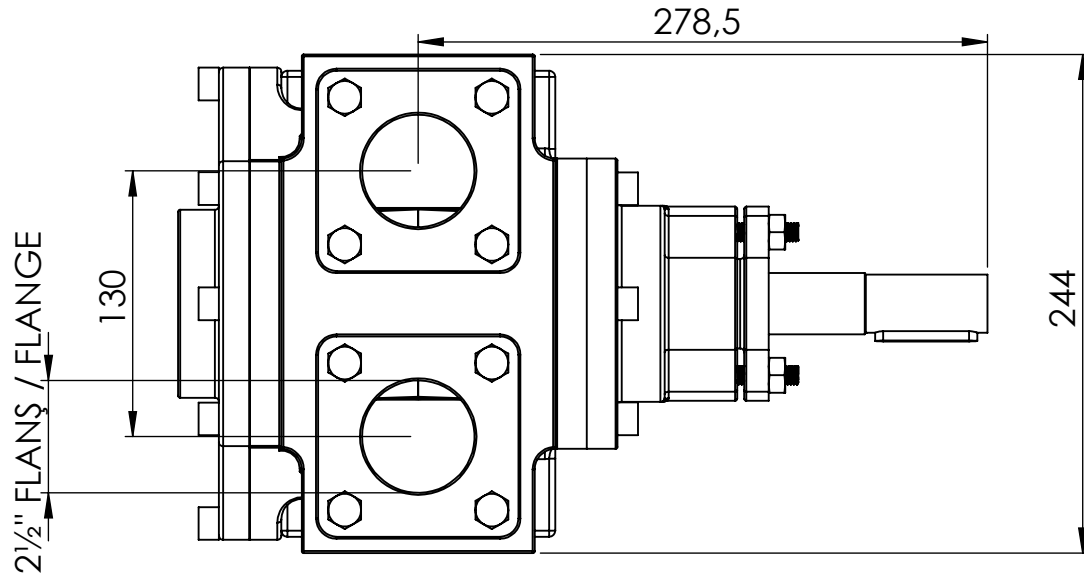
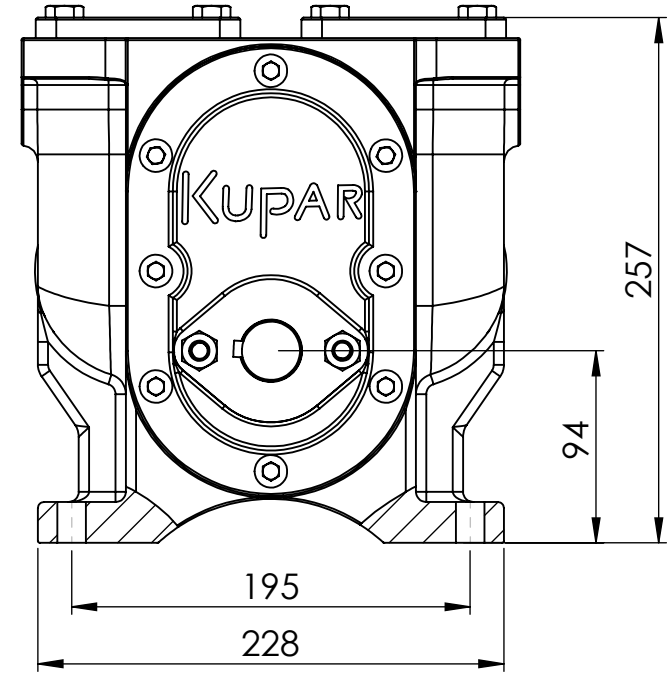
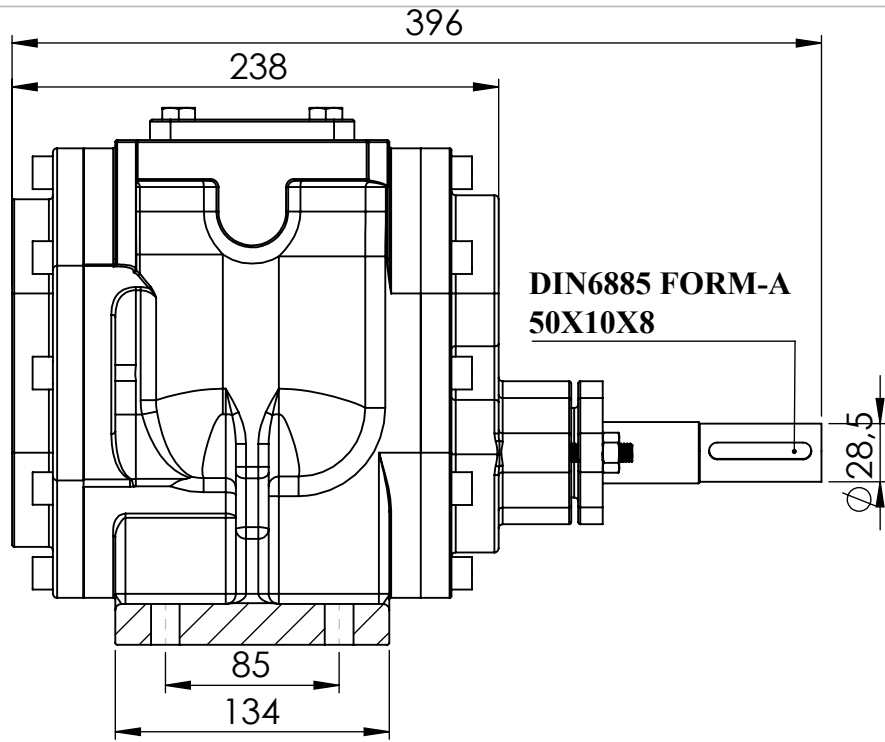

	İSİM / NAME	NOTLAR / NOTES	PARÇA ADI / PART NAME:
ÇİZEN / DRAWN	MUSTAFA KÜÇÜKPARMAK	BU TEKNİK RESİMDEKİ TÜM BİLGİNİN MÜLKİYETİ KUCUKPARMAK MUH.SAN.TIC.LTD.ŞTİ AİTTİR. YAZILI İZİN OLMADAN, KISMEN YADA TAMAMEN ÇOĞALTMALAR YAPMAK YASAKTIR.	<b>KÇP 2 1/2"</b> <b>ÇAVUŞ DİŞLİ POMPA</b> <b>HERRINGBONE GEAR PUMP</b>
DENETLEYEN / CONTROLLED	HARUN POLAT		
ONAY / APPROVED	BAŞAR KÜÇÜKPARMAK	ALL INFORMATION IN THIS TECHNICAL DRAWING PROPERTY KUCUKPARMAK MUH.SAN.TIC.LTD.ŞTİ IT BELONGS. WITHOUT WRITTEN PERMISSION, PARTIALLY OR COMPLETELY REPRODUCTIONS ARE PROHIBITED.	
REVİZYON TARİHİ / DATE OF REVISION	10.10.2022		



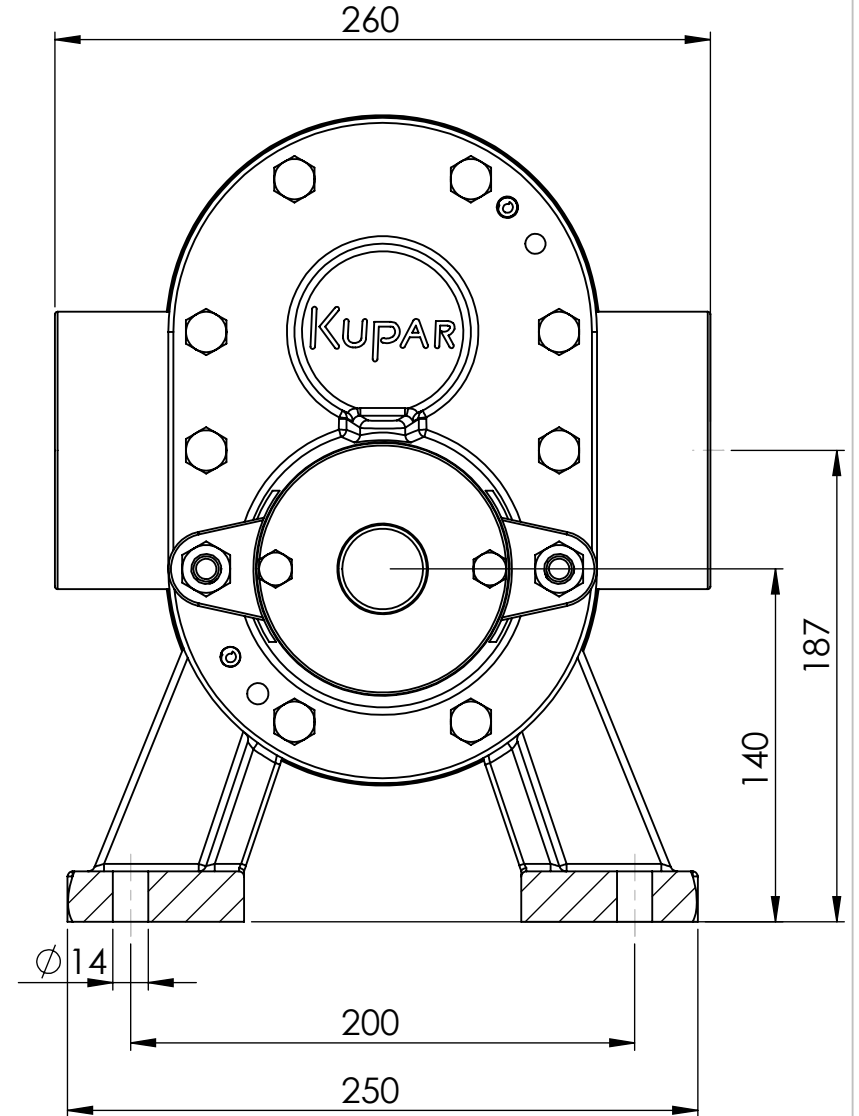
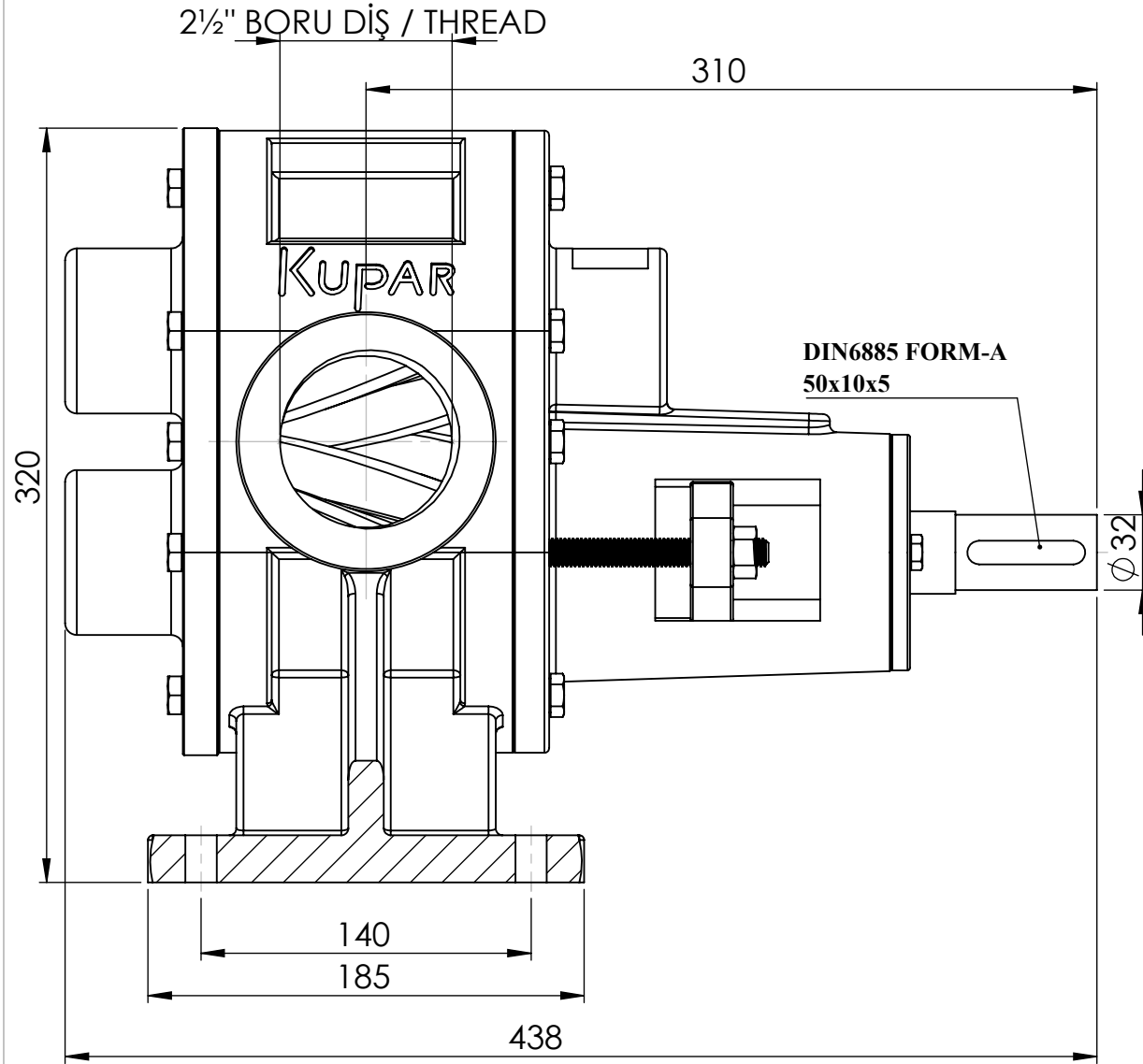

	İSİM / NAME	NOTLAR / NOTES	PARÇA ADI / PART NAME:
ÇİZEN / DRAWN	VEDAT KARTAL		<b>KHP2 1/2"</b> <b>HELİS DİŞLİ POMPA</b> <b>HELICAL GEAR PUMP</b>
DENETLEYEN / CONTROLLED	HARUN POLAT		
ONAY / APPROVED	BAŞAR KÜÇÜKPARMAK		
REVİZYON TARİHİ / DATE OF REVISION	04.04.2022		



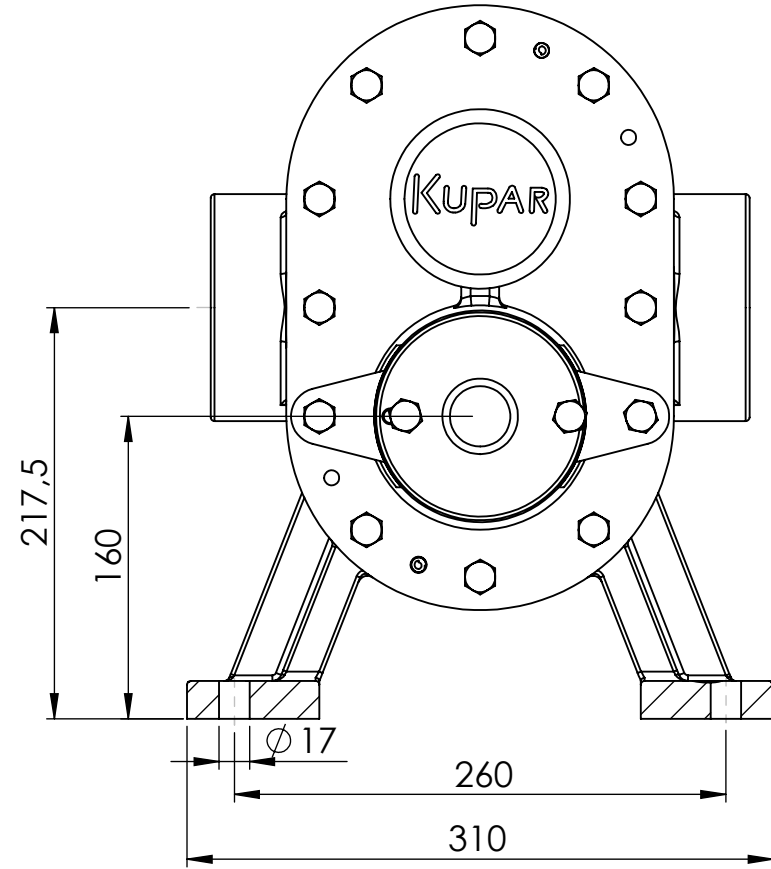
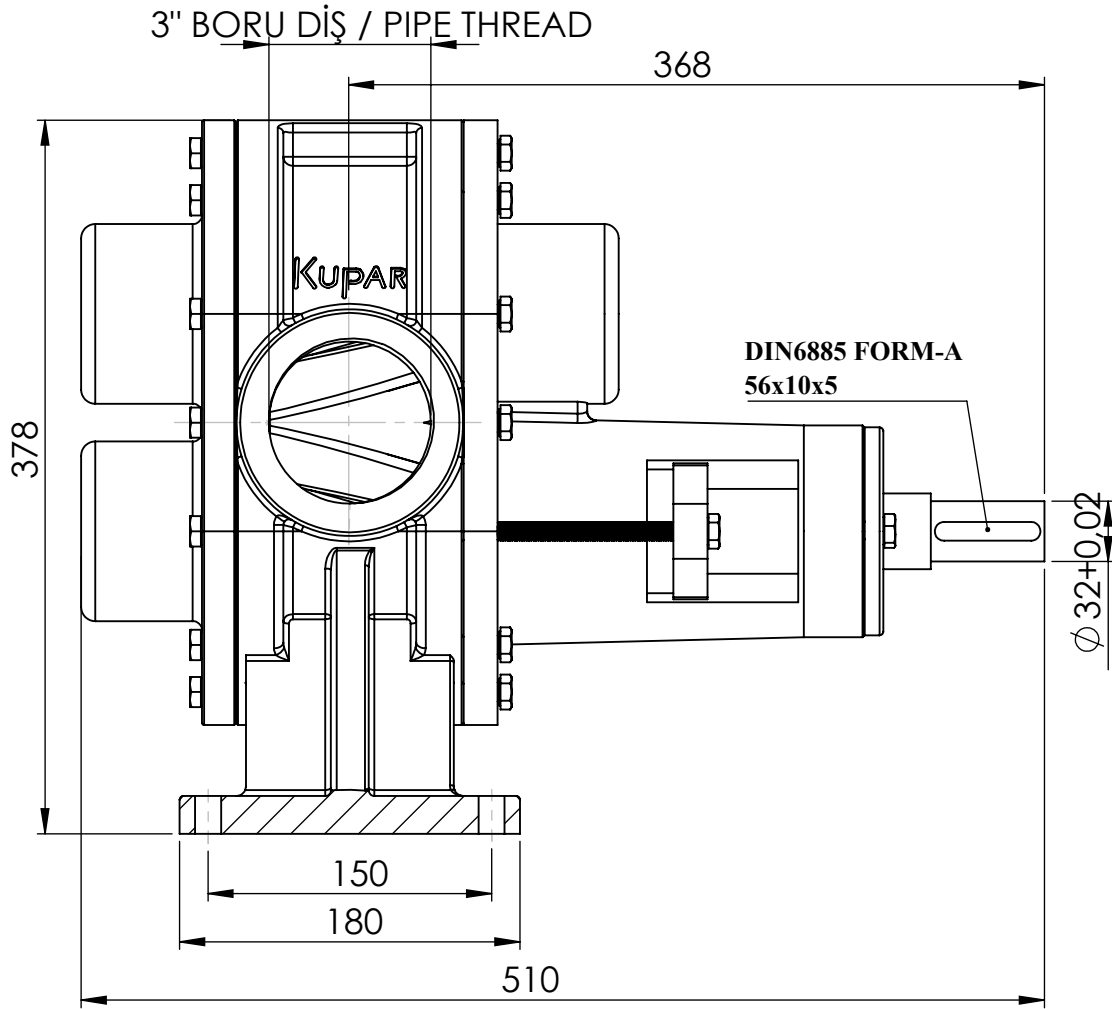

	İSİM / NAME	NOTLAR / NOTES	PARÇA ADI / PART NAME:
ÇİZEN / DRAWN	VEDAT KARTAL		<b>KHP3" HELİS DİŞLİ POMPA HELICAL GEAR PUMP</b>
DENETLEYEN / CONTROLLED	HARUN POLAT		
ONAY / APPROVED	BAŞAR KÜÇÜKPARMAK		
REVİZYON TARİHİ / DATE OF REVISION	11.04.2022		





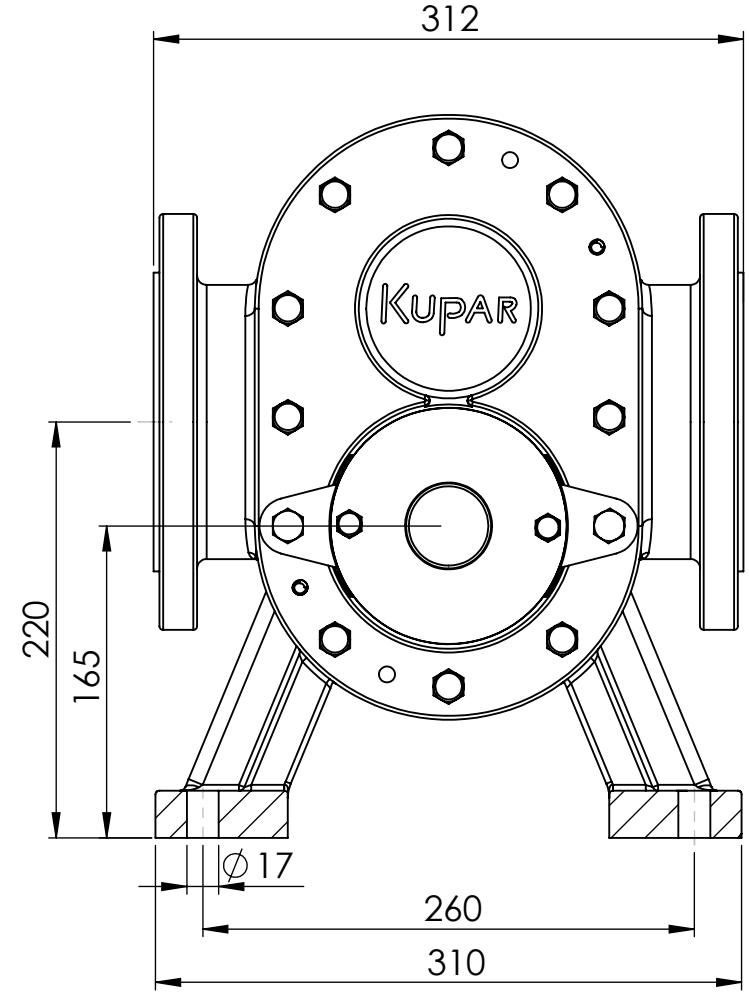
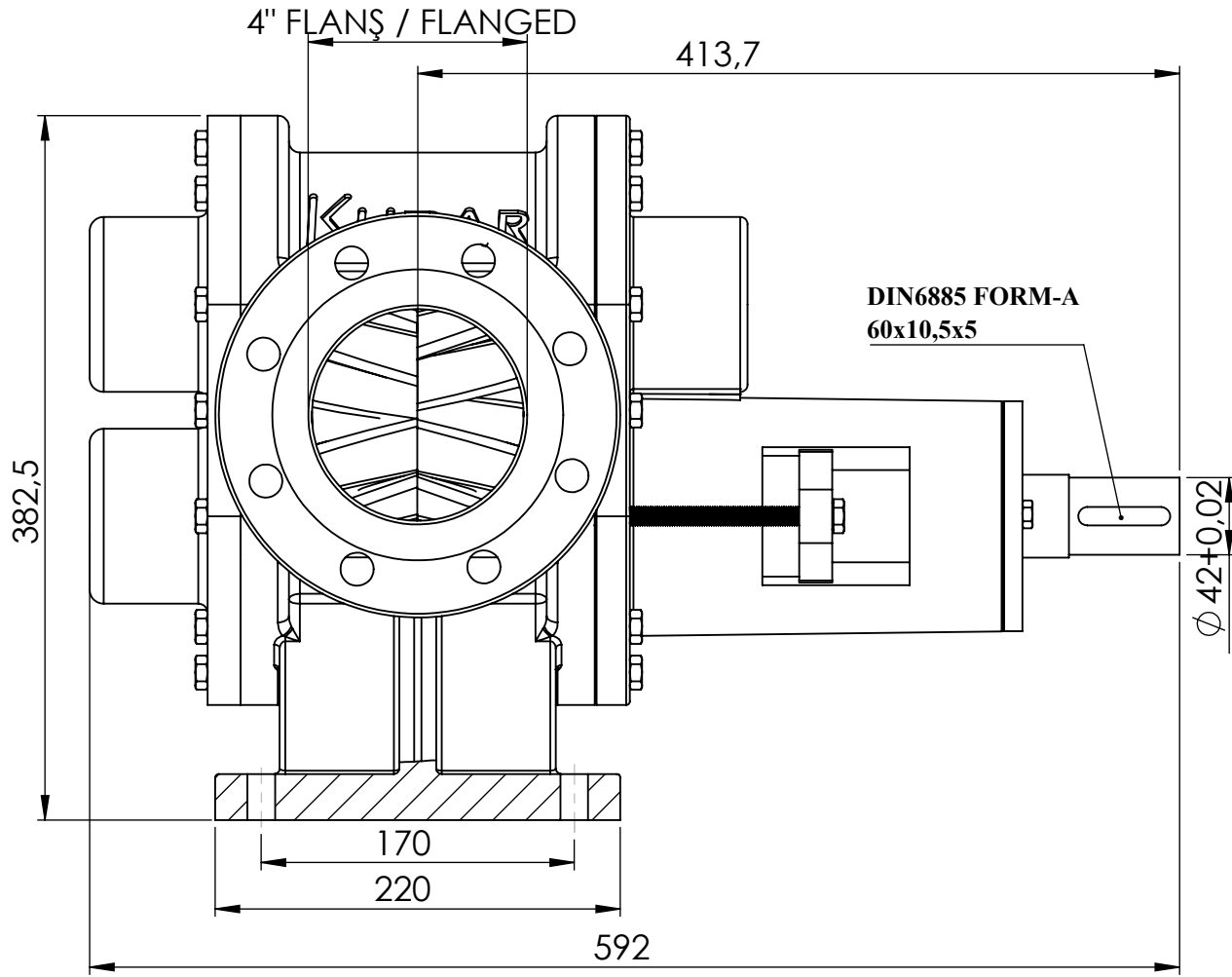

	İSİM / NAME	NOTLAR / NOTES	PARÇA ADI / PART NAME:
ÇİZEN / DRAWN	VEDAT KARTAL		<b>KHP4"</b> <b>HELİS DİŞLİ POMPA</b> <b>HELICAL GEAR PUMP</b>
DENETLEYEN / CONTROLLED	HARUN POLAT		
ONAY / APPROVED	BAŞAR KÜÇÜKPARMAK		
REVİZYON TARİHİ / DATE OF REVISION	11.04.2022		



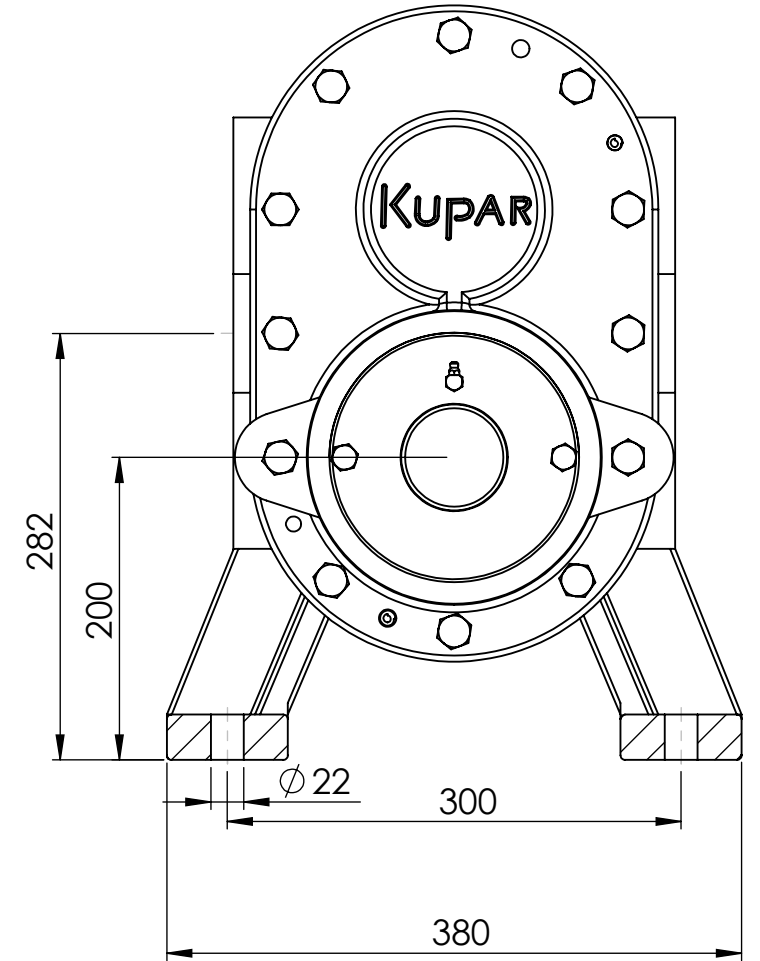
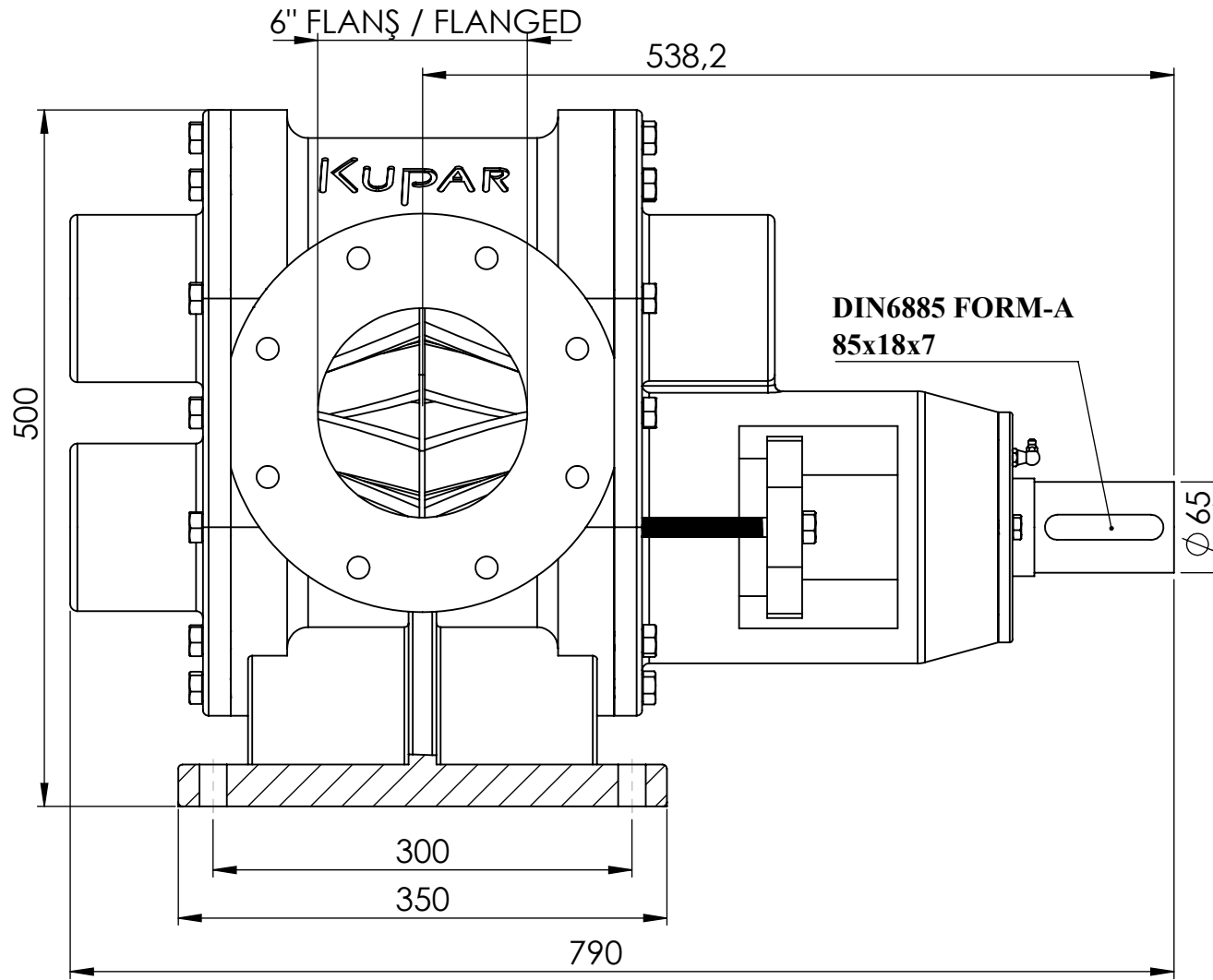

	İSİM / NAME	NOTLAR / NOTES	PARÇA ADI / PART NAME:
ÇİZEN / DRAWN	VEDAT KARTAL		<b>KHP6"</b> <b>HELİS DİŞLİ POMPA</b> <b>HELICAL GEAR PUMP</b>
DENETLEYEN / CONTROLLED	HARUN POLAT		
ONAY / APPROVED	BAŞAR KÜÇÜKPARMAK		
REVİZYON TARİHİ / DATE OF REVISION	11.04.2022		





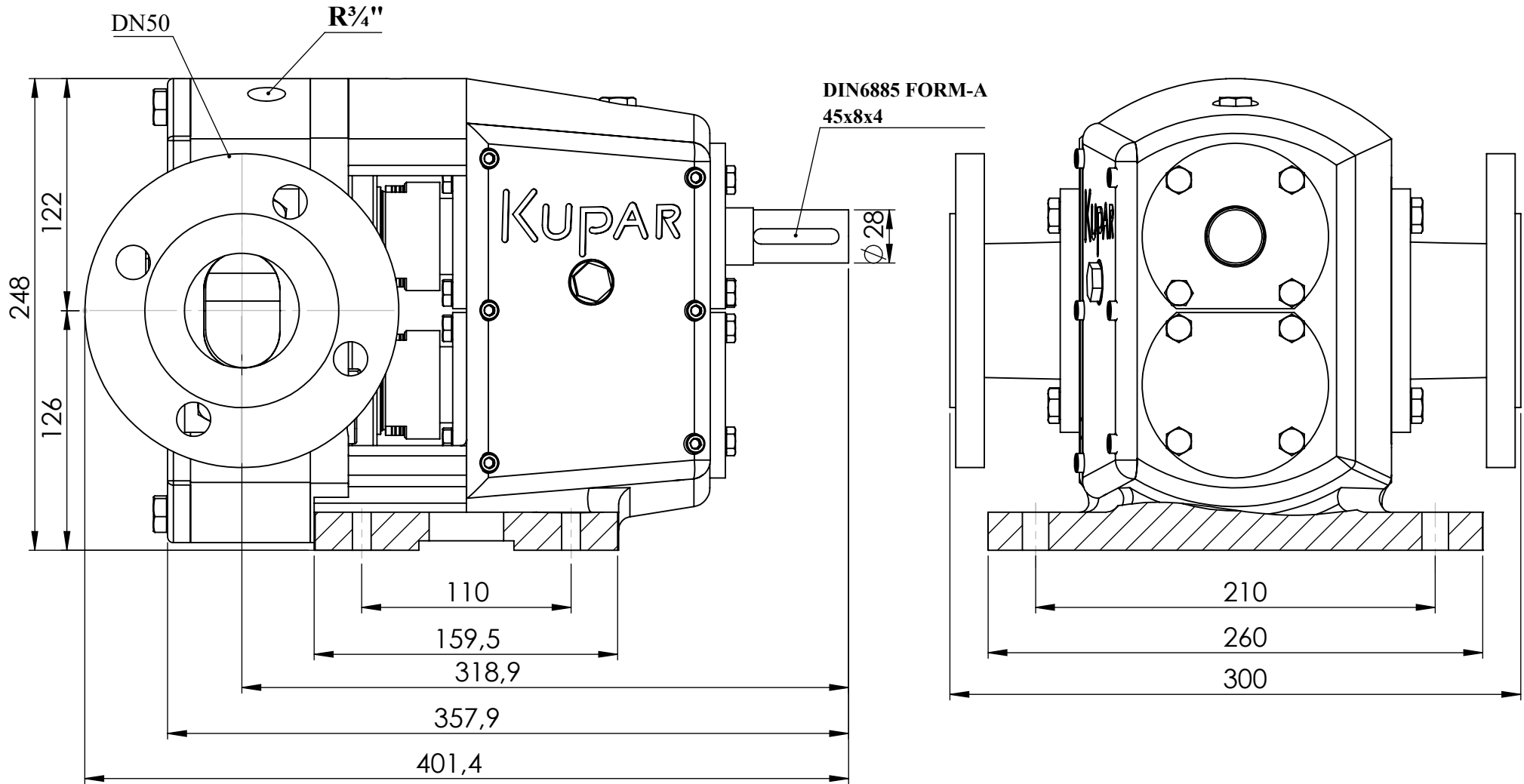



	İSİM / NAME	NOTLAR / NOTES	PARÇA ADI / PART NAME:
ÇİZEN / DRAWN	VEDAT KARTAL	BU TEKNİK RESİMDEKİ TÜM BİLGİNİN MÜLKİYETİ KUCUKPARMAK MUH.SAN.TIC.LTD.ŞTİ AİTTİR. YAZILI İZİN OLMADAN, KISMEN YADA TAMAMEN ÇOĞALTMALAR YAPMAK YASAKTIR. ALL INFORMATION IN THIS TECHNICAL DRAWING PROPERTY KUCUKPARMAK MUH.SAN.TIC.LTD.ŞTİ IT BELONGS. WITHOUT WRITTEN PERMISSION, PARTIALLY OR COMPLETELY REPRODUCTIONS ARE PROHIBITED.	<b>KLP2"</b> <b>LOBLU POMPA</b> <b>LOBE PUMP</b>
DENETLEYEN / CONTROLLED	HARUN POLAT		
ONAY / APPROVED	BAŞAR KÜÇÜKPARMAK		
REVİZYON TARİHİ / DATE OF REVISION	23.05.2022		

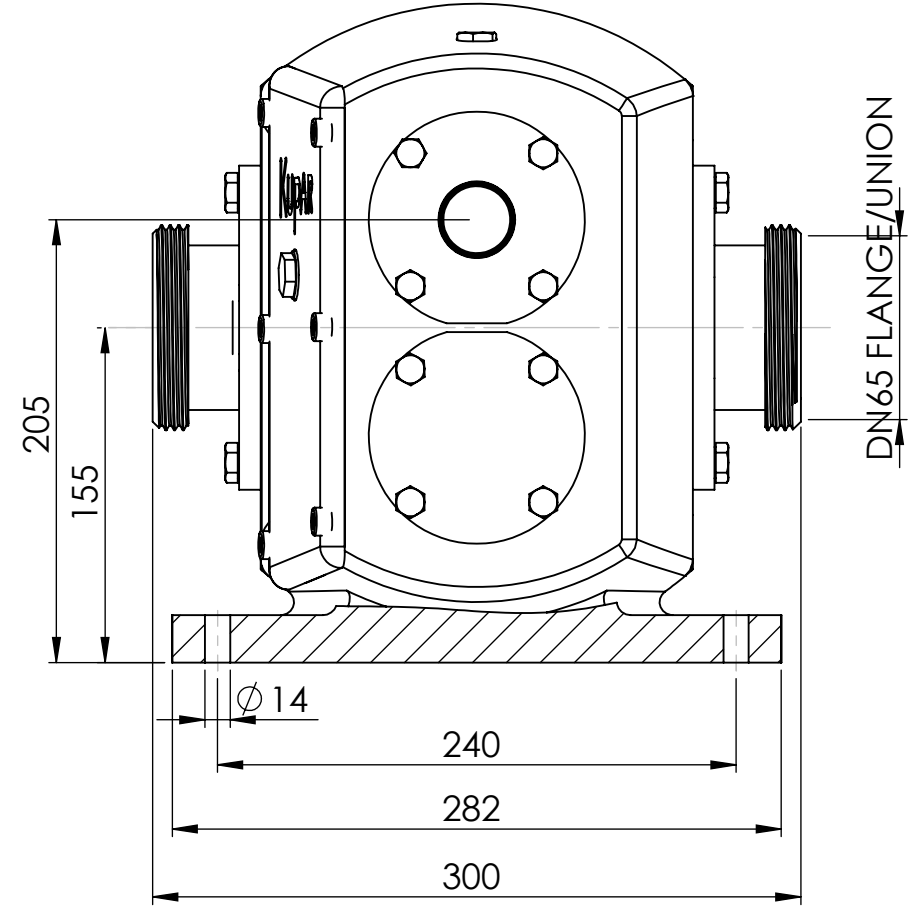
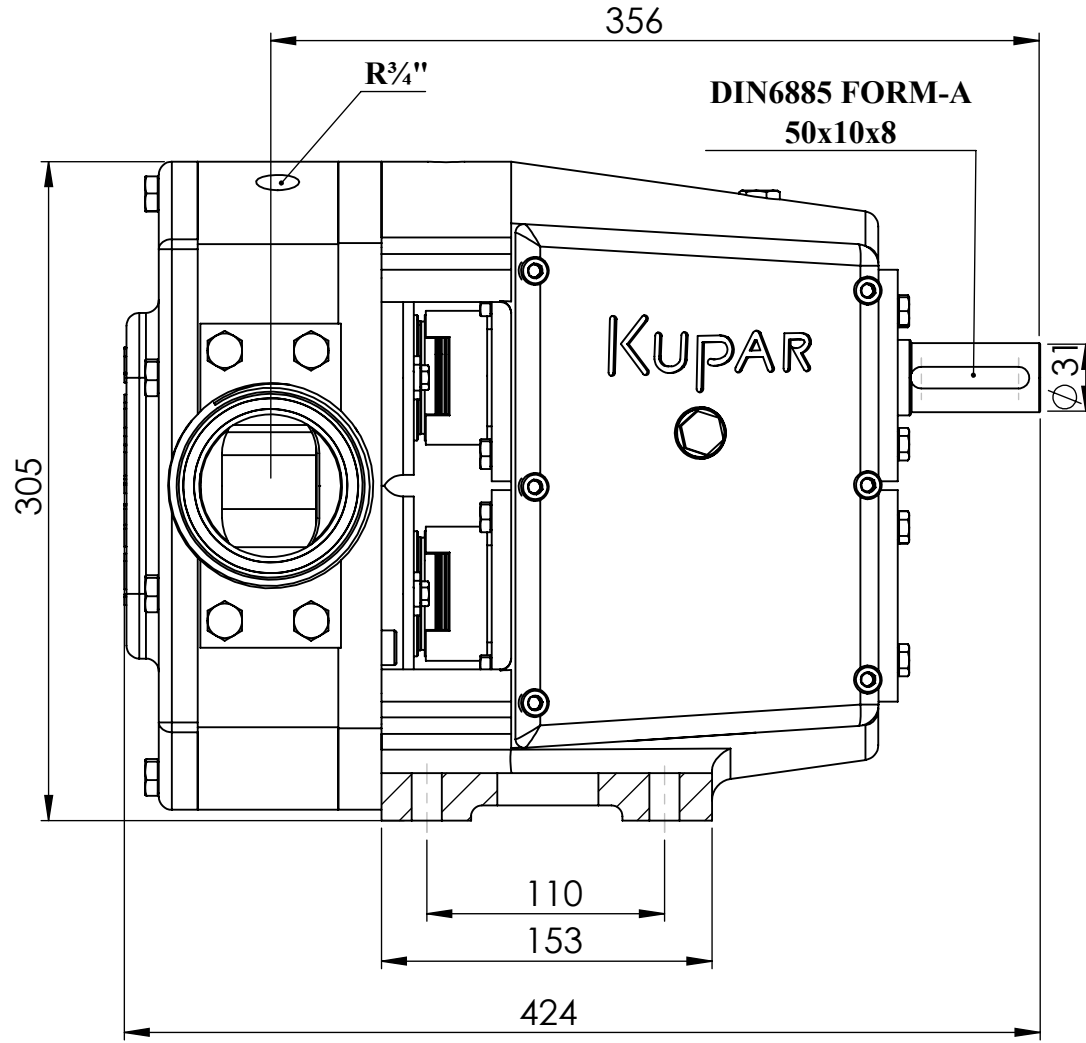



	İSİM / NAME	NOTLAR / NOTES	PARÇA ADI / PART NAME:	
ÇİZEN / DRAWN	VEDAT KARTAL	BU TEKNİK RESİMDEKİ TÜM BİLGİNİN MÜLKİYETİ KUCUKPARMAK MUH.SAN.TIC.LTD.ŞTİ AİTTİR. YAZILI İZİN OLMADAN, KISMEN YADA TAMAMEN ÇOĞALTMALAR YAPMAK YASAKTIR.  ALL INFORMATION IN THIS TECHNICAL DRAWING PROPERTY KUCUKPARMAK MUH.SAN.TIC.LTD.ŞTİ IT BELONGS. WITHOUT WRITTEN PERMISSION, PARTIALLY OR COMPLETELY REPRODUCTIONS ARE PROHIBITED.	<b>KLP2½"</b> <b>LOBLU POMPA</b> <b>LOBE PUMP</b>	
DENETLEYEN / CONTROLLED	HARUN POLAT			
ONAY / APPROVED	BAŞAR KÜÇÜKPARMAK			
REVİZYON TARİHİ / DATE OF REVISION	23.05.2022			

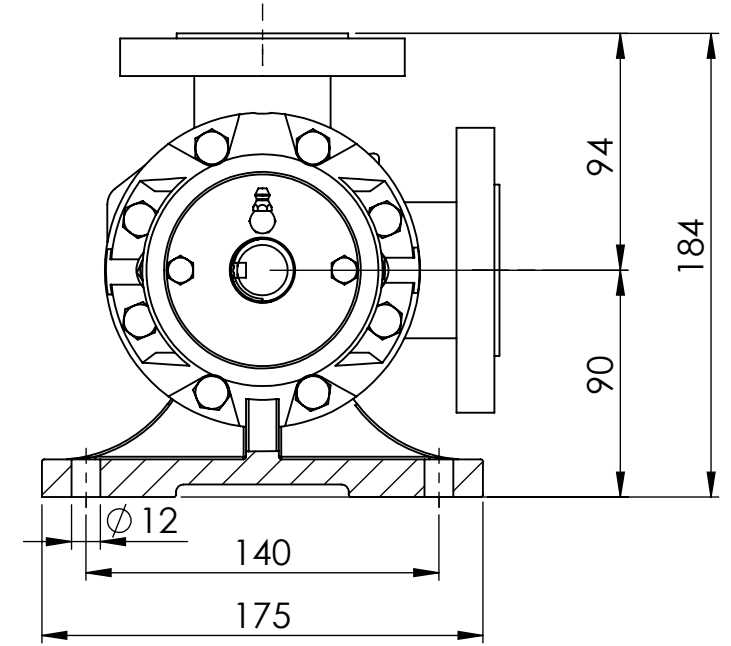
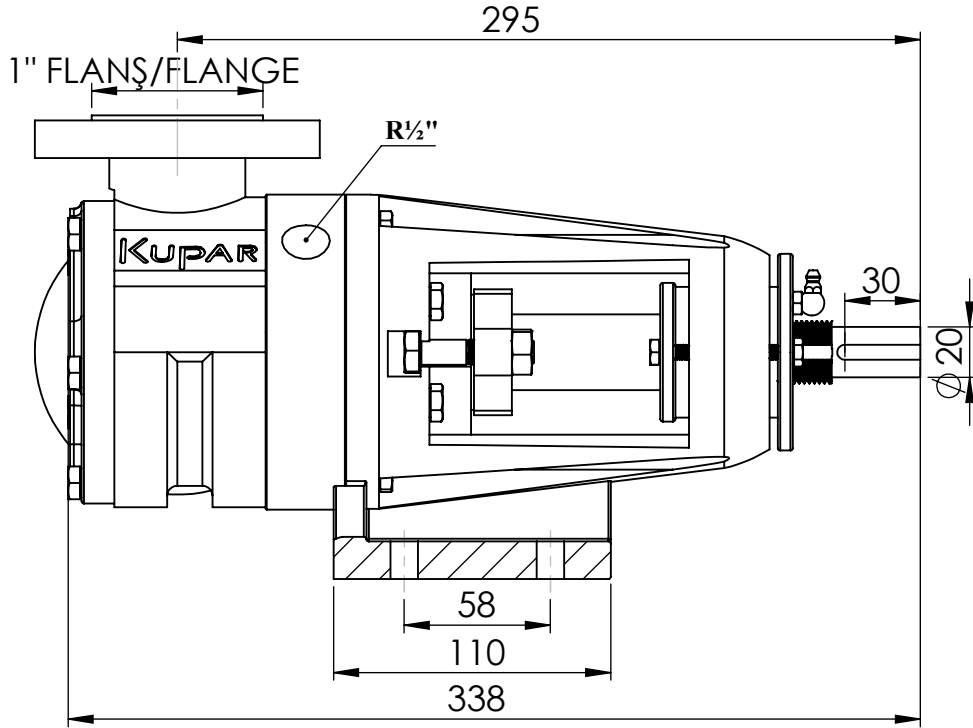

	İSİM / NAME	NOTLAR / NOTES
ÇİZEN/ DRAWN	VEDAT KARTAL	BU TEKNİK RESİMDEKİ TÜM BİLGİNİN MÜLKİYETİ KUCUKPARMAK MUH.SAN.TIC.LTD.ŞTİ AİTTİR. YAZILI İZİN OLMADAN, KISMEN YADA TAMAMEN ÇOĞALTMALAR YAPMAK YASAKTIR.
DENETLEYEN / CONTROLLED	HARUN POLAT	
ONAY / APPROVED	BAŞAR KÜÇÜKPARMAK	ALL INFORMATION IN THIS TECHNICAL DRAWING PROPERTY KUCUKPARMAK MUH.SAN.TIC.LTD.ŞTİ IT BELONGS. WITHOUT WRITTEN PERMISSION, PARTIALLY OR COMPLETELY REPRODUCTIONS ARE PROHIBITED.
REVİZYON TARİHİ / DATE OF REVISION	09.09.2022	

PARÇA ADI / PART NAME:

**KIP1"**  
**İÇ DİŞLİ POMPA**  
**INTERNAL GEAR PUMP**



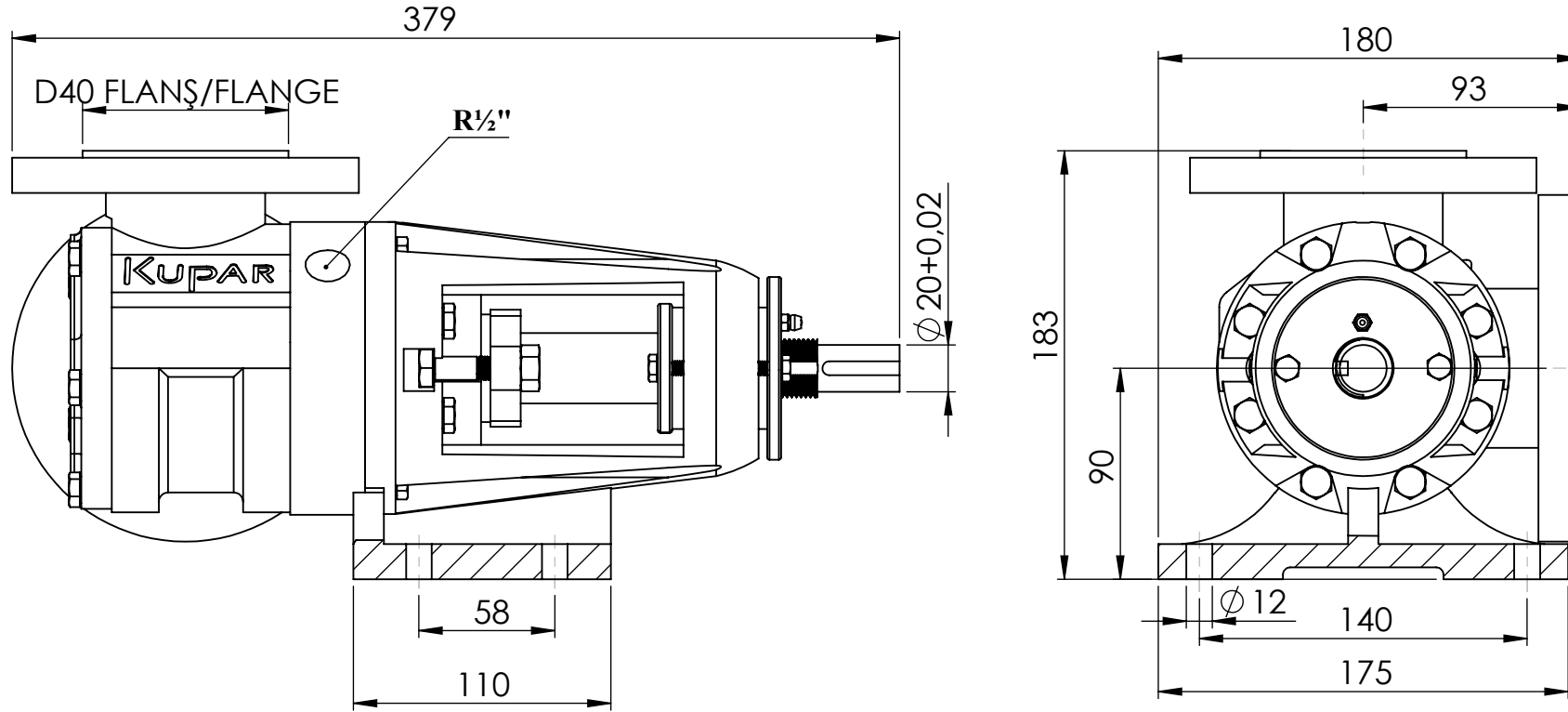

	İSİM / NAME	NOTLAR / NOTES	PARÇA ADI / PART NAME:
ÇİZEN / DRAWN	VEDAT KARTAL	BU TEKNİK RESİMDEKİ TÜM BİLGİNİN MÜLKİYETİ KUCUKPARMAK MUH.SAN.TIC.LTD.ŞTİ AİTTİR. YAZILI İZİN OLMADAN, KISMEN YADA TAMAMEN ÇOĞALTMALAR YAPMAK YASAKTIR. ALL INFORMATION IN THIS TECHNICAL DRAWING PROPERTY KUCUKPARMAK MUH.SAN.TIC.LTD.ŞTİ IT BELONGS. WITHOUT WRITTEN PERMISSION, PARTIALLY OR COMPLETELY REPRODUCTIONS ARE PROHIBITED.	<b>KIPK1½"</b> <b>İÇ DİŞLİ POMPA</b> <b>INTERNAL GEAR PUMP</b>
DENETLEYEN / CONTROLLED	HARUN POLAT		
ONAY / APPROVED	BAŞAR KÜÇÜKPARMAK		
REVİZYON TARİHİ / DATE OF REVISION	09.09.2021		



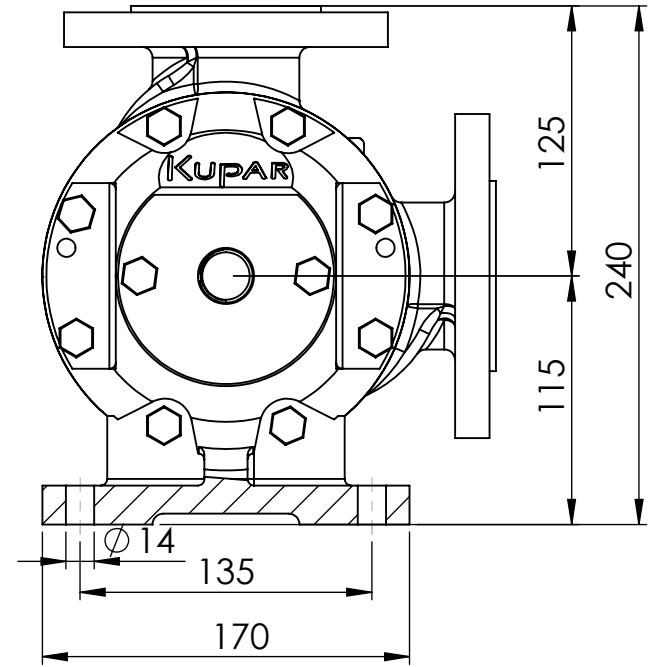
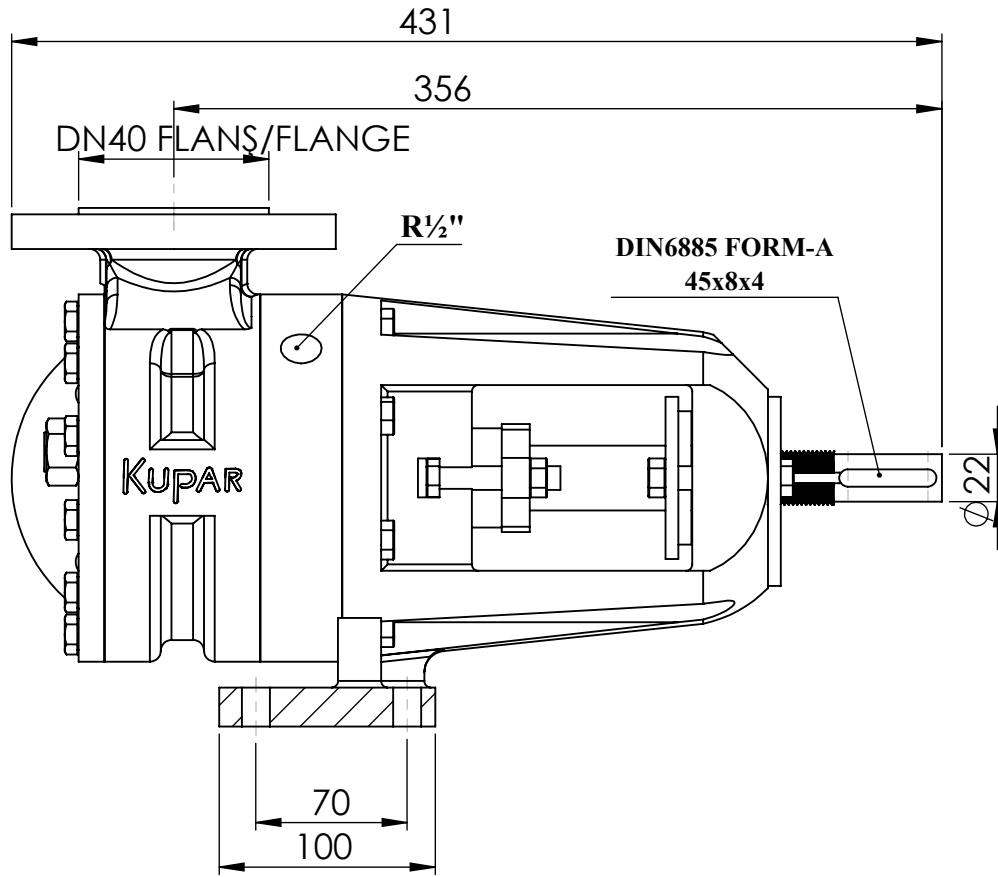

	İSİM / NAME	NOTLAR / NOTES	PARÇA ADI / PART NAME:
ÇİZEN / DRAWN	VEDAT KARTAL	BU TEKNİK RESİMDEKİ TÜM BİLGİNİN MÜLKİYETİ KUCUKPARMAK MUH.SAN.TIC.LTD.ŞTİ AİTTİR. YAZILI İZİN OLMADAN, KISMEN YADA TAMAMEN ÇOĞALTMALAR YAPMAK YASAKTIR.  ALL INFORMATION IN THIS TECHNICAL DRAWING PROPERTY KUCUKPARMAK MUH.SAN.TIC.LTD.ŞTİ IT BELONGS. WITHOUT WRITTEN PERMISSION, PARTIALLY OR COMPLETELY REPRODUCTIONS ARE PROHIBITED.	<b>KIP1½"</b> <b>İÇ DİŞLİ POMPA</b> <b>INTERNAL GEAR PUMP</b>
DENETLEYEN / CONTROLLED	HARUN POLAT		
ONAY / APPROVED	BAŞAR KÜÇÜKPARMAK		
REVİZYON TARİHİ / DATE OF REVISION	09.09.2021		





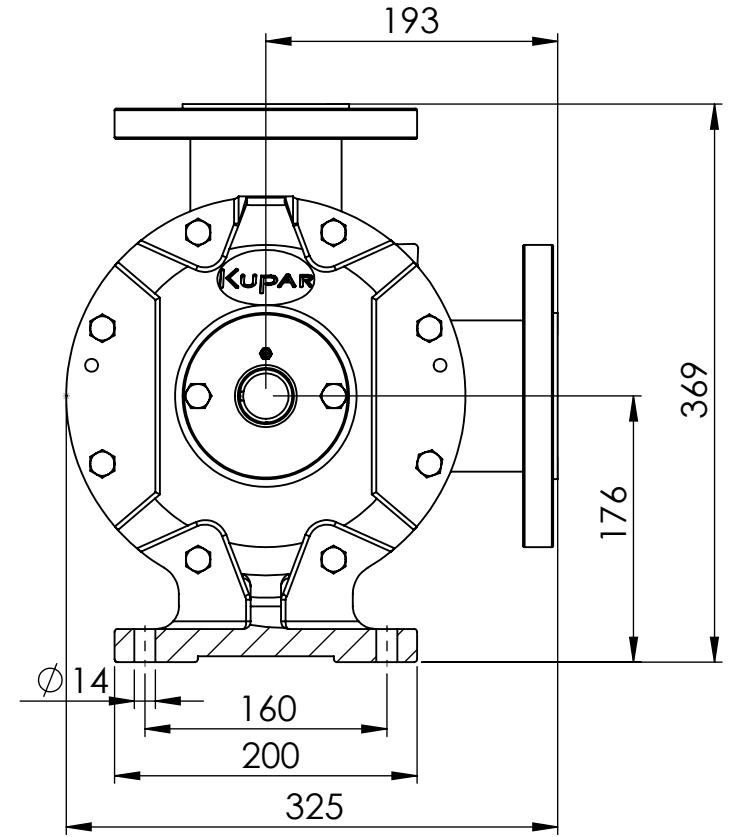
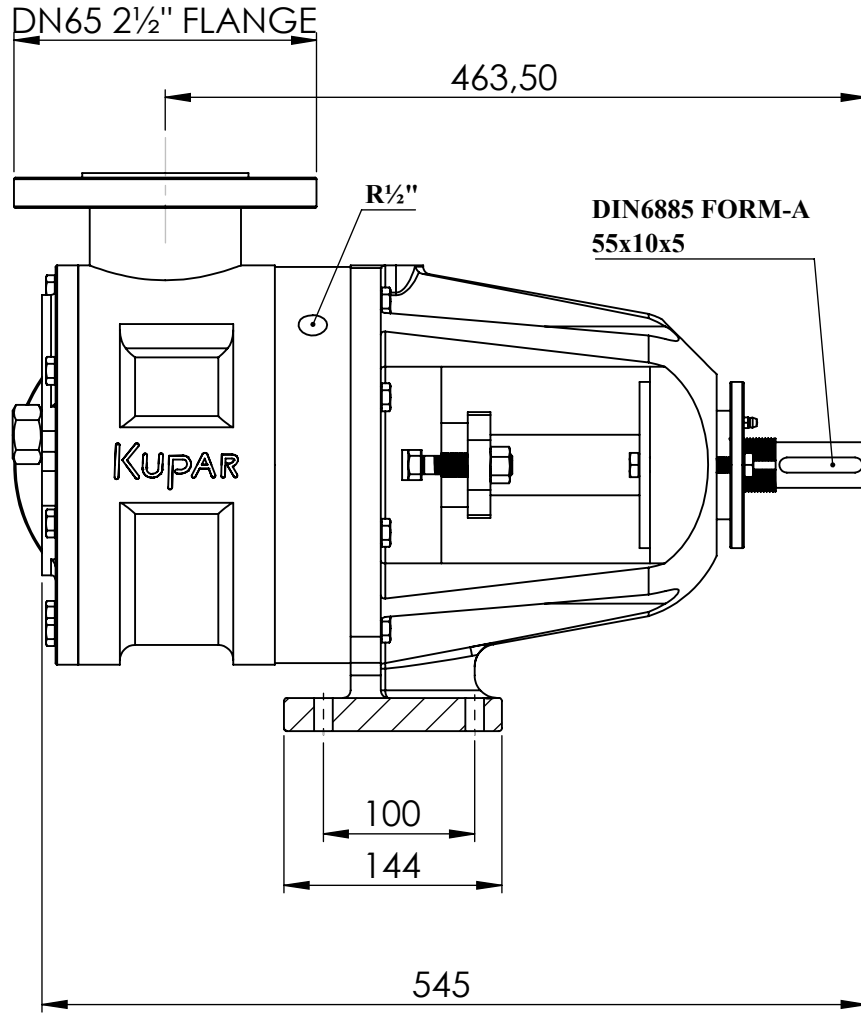



	İSİM / NAME	NOTLAR / NOTES	PARÇA ADI / PART NAME:
ÇİZEN / DRAWN	VEDAT KARTAL		<b>KIPK2 1/2"</b> <b>İÇ DİŞLİ POMPA</b> <b>INTERNAL GEAR PUMP</b>
DENETLEYEN / CONTROLLED	HARUN POLAT		
ONAY / APPROVED	BAŞAR KÜÇÜKPARMAK		
REVİZYON TARİHİ / DATE OF REVISION	13.04.2022		

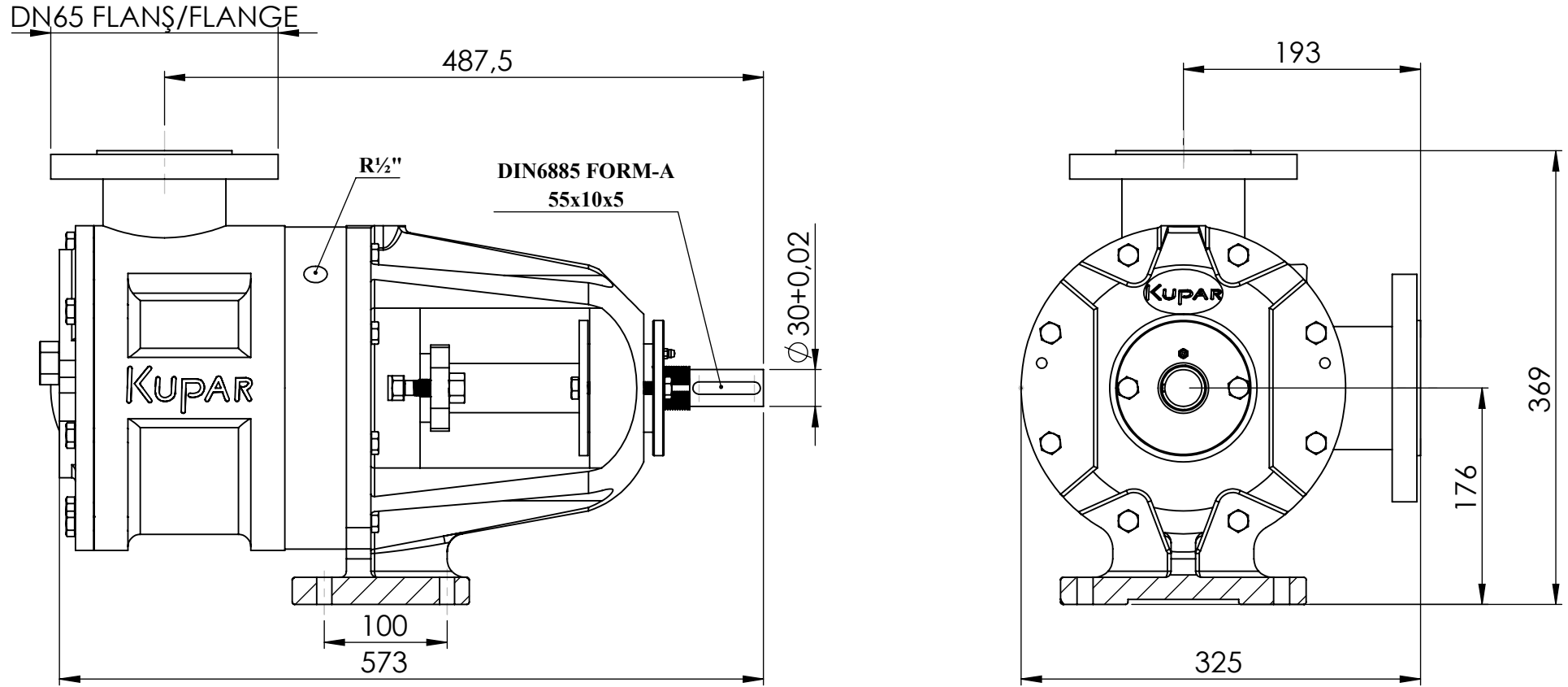



	İSİM / NAME	NOTLAR / NOTES	PARÇA ADI / PART NAME:
ÇİZEN/ DRAWN	VEDAT KARTAL	BU TEKNİK RESİMDEKİ TÜM BİLGİNİN MÜLKİYETİ KUCUKPARMAK MUH.SAN.TIC.LTD.ŞTİ AİTTİR. YAZILI İZİN OLMADAN, KISMEN YADA TAMAMEN ÇOĞALTMALAR YAPMAK YASAKTIR.  ALL INFORMATION IN THIS TECHNICAL DRAWING PROPERTY KUCUKPARMAK MUH.SAN.TIC.LTD.ŞTİ IT BELONGS. WITHOUT WRITTEN PERMISSION, PARTIALLY OR COMPLETELY REPRODUCTIONS ARE PROHIBITED.	<b>KIP2½"</b> <b>İÇ DİŞLİ POMPA</b> <b>INTERNAL GEAR PUMP</b>
DENETLEYEN / CONTROLLED	HARUN POLAT		
ONAY / APPROVED	BAŞAR KÜÇÜKPARMAK		
REVİZYON TARİHİ / DATE OF REVISION	11.05.2022		

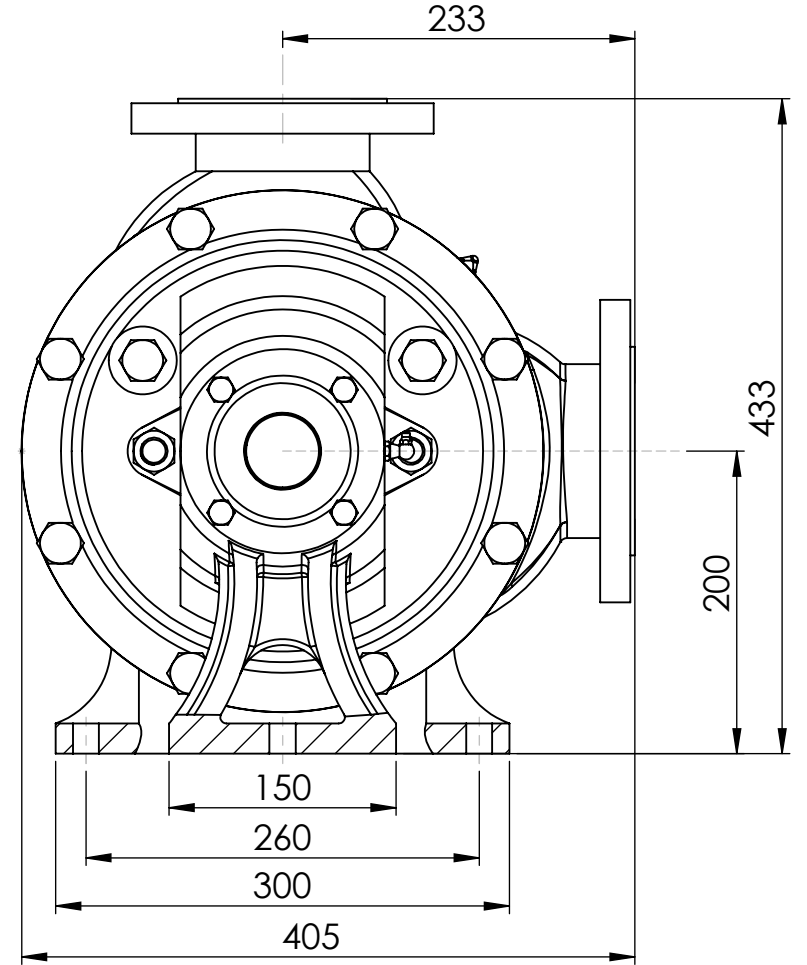
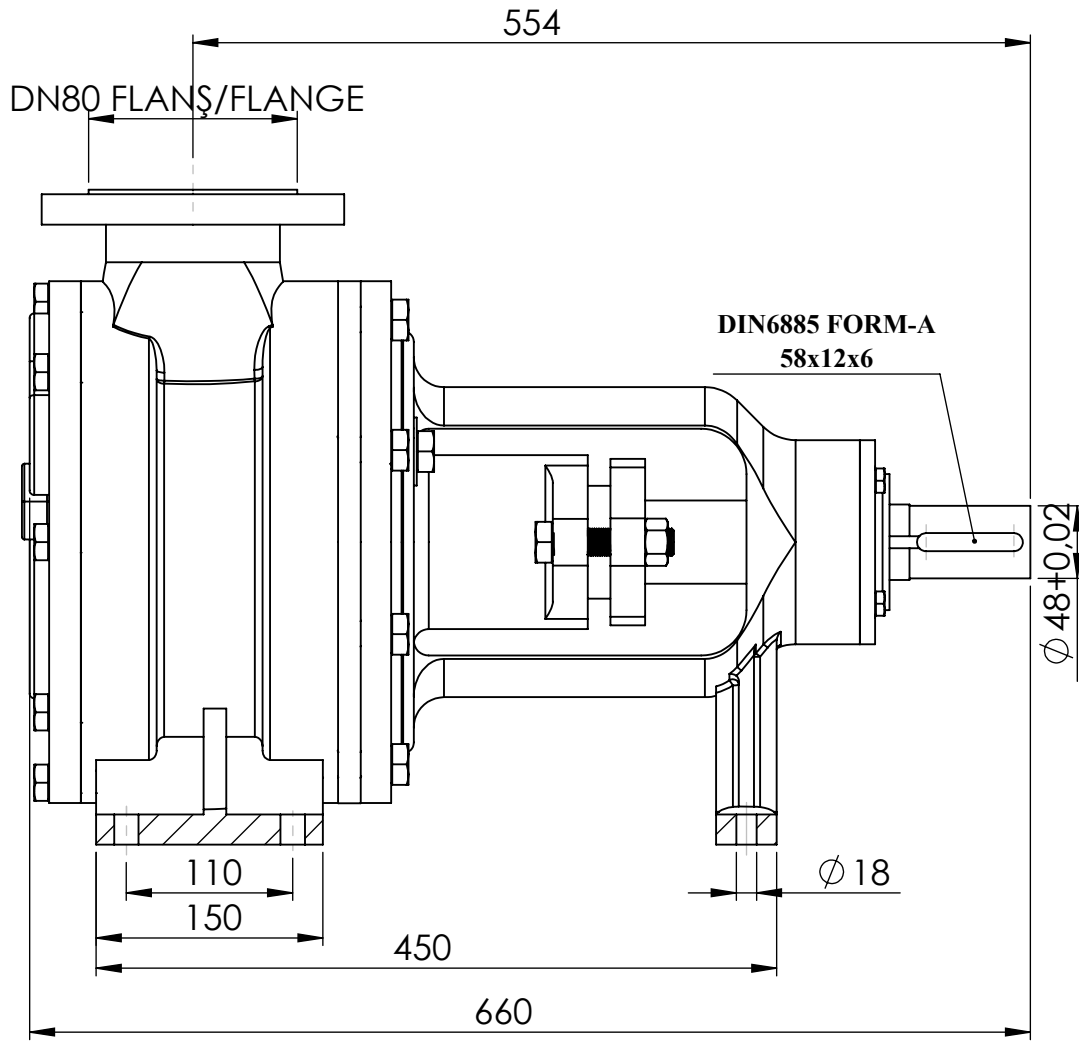

	İSİM / NAME	NOTLAR / NOTES	PARÇA ADI / PART NAME:
ÇİZEN / DRAWN	VEDAT KARTAL	BU TEKNİK RESİMDEKİ TÜM BİLGİNİN MÜLKİYETİ KUCUKPARMAK MUH.SAN.TIC.LTD.ŞTİ AİTTİR. YAZILI İZİN OLMADAN, KISMEN YADA TAMAMEN ÇOĞALTMALAR YAPMAK YASAKTIR. ALL INFORMATION IN THIS TECHNICAL DRAWING PROPERTY KUCUKPARMAK MUH.SAN.TIC.LTD.ŞTİ IT BELONGS. WITHOUT WRITTEN PERMISSION, PARTIALLY OR COMPLETELY REPRODUCTIONS ARE PROHIBITED.	<b>KIP3"</b> <b>İÇ DİŞLİ POMPA</b> <b>INTERNAL GEAR PUMP</b>
DENETLEYEN / CONTROLLED	HARUN POLAT		
ONAY / APPROVED	BAŞAR KÜÇÜKPARMAK		
REVİZYON TARİHİ / DATE OF REVISION	11.05.2022		



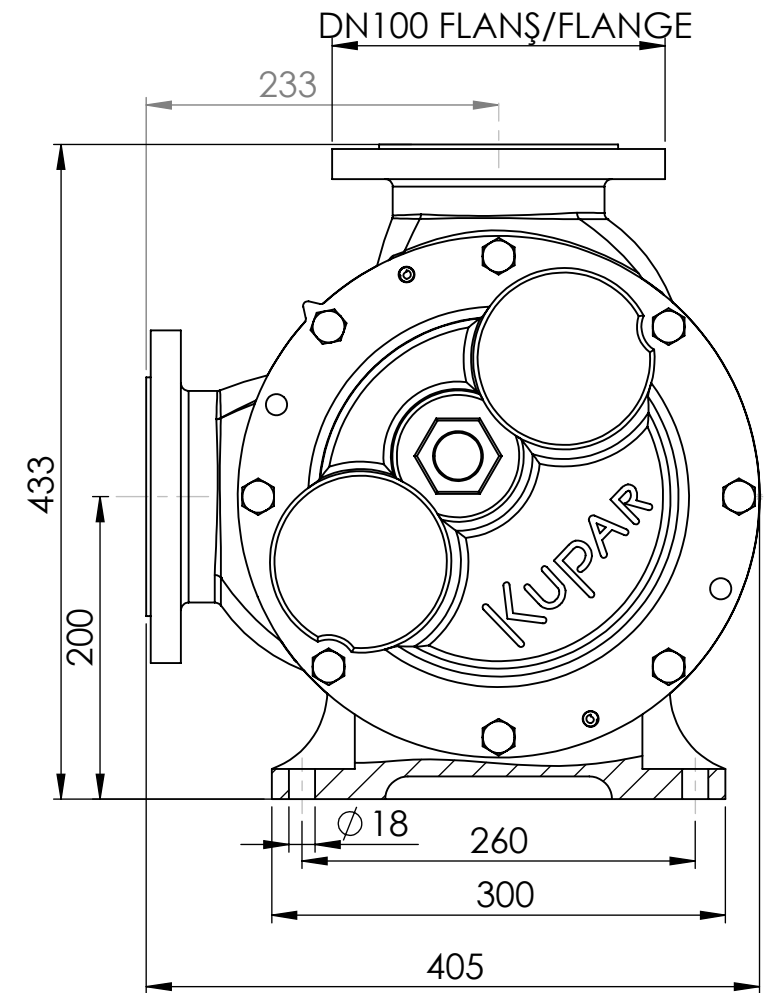
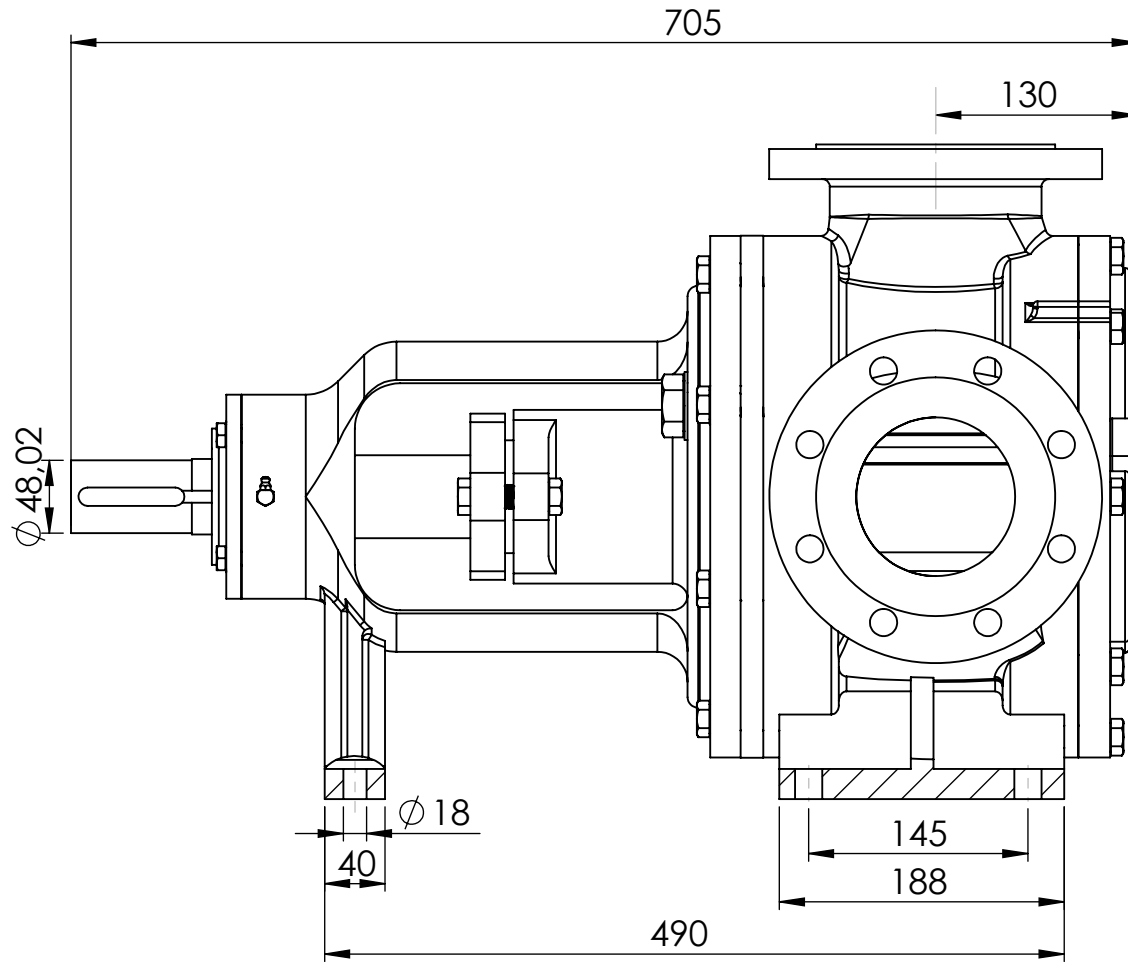

	İSİM / NAME	NOTLAR / NOTES	PARÇA ADI / PART NAME:
ÇİZEN/ DRAWN	VEDAT KARTAL	BU TEKNİK RESİMDEKİ TÜM BİLGİNİN MÜLKİYETİ KUCUKPARMAK MUH.SAN.TIC.LTD.ŞTİ AİTTİR. YAZILI İZİN OLMADAN, KISMEN YADA TAMAMEN ÇOGALTMALAR YAPMAK YASAKTIR. ALL INFORMATION IN THIS TECHNICAL DRAWING PROPERTY KUCUKPARMAK MUH.SAN.TIC.LTD.ŞTİ IT BELONGS. WITHOUT WRITTEN PERMISSION, PARTIALLY OR COMPLETELY REPRODUCTIONS ARE PROHIBITED.	<b>KIP4"</b> <b>İÇ DİŞLİ POMPA</b> <b>INTERNAL GEAR PUMP</b>
DENETLEYEN / CONTROLLED	HARUN POLAT		
ONAY / APPROVED	BAŞAR KÜÇÜKPARMAK		
REVİZYON TARİHİ / DATE OF REVISION	09.06.2022		



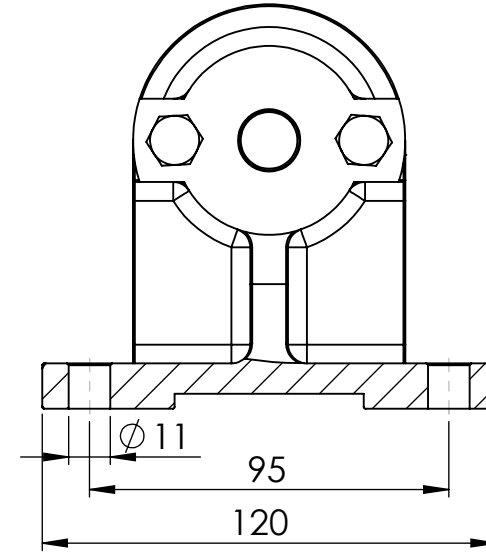
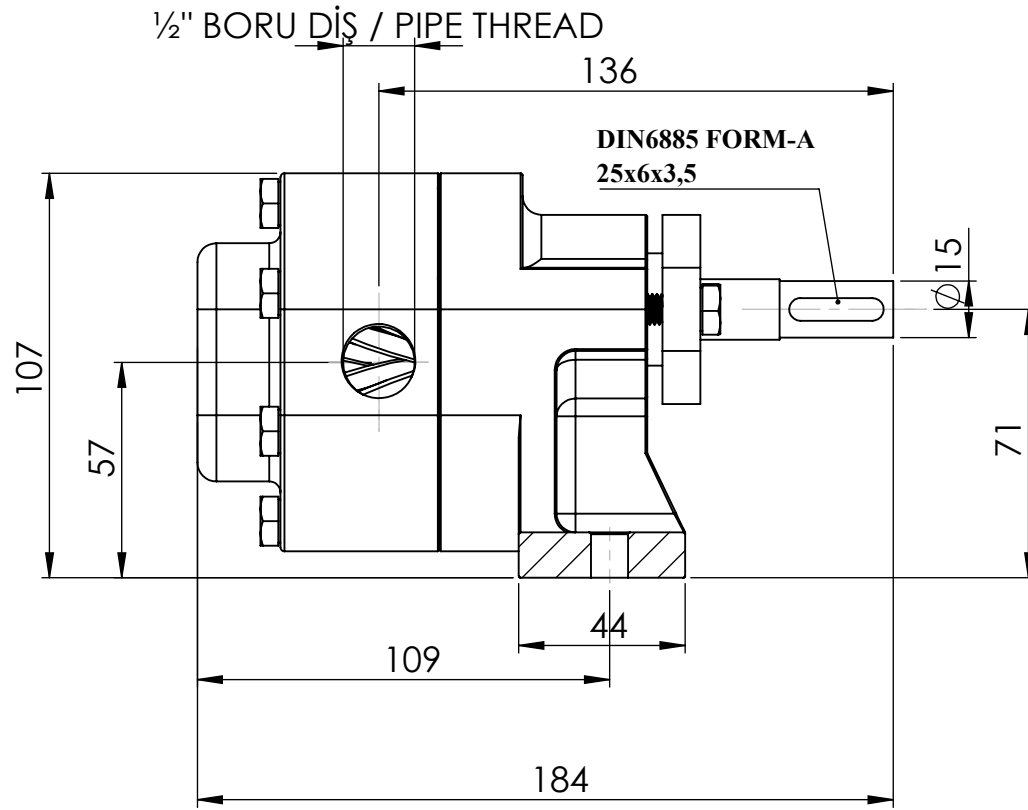

	İSİM / NAME	NOTLAR / NOTES	PARÇA ADI / PART NAME:
ÇİZEN / DRAWN	VEDAT KARTAL		<b>KHP 1/2"</b> <b>HELİS DİŞLİ POMPA</b> <b>HELICAL GEAR PUMP</b>
DENETLEYEN / CONTROLLED	HARUN POLAT		
ONAY / APPROVED	BAŞAR KÜÇÜKPARMAK		
REVİZYON TARİHİ / DATE OF REVISION	11.04.2022		



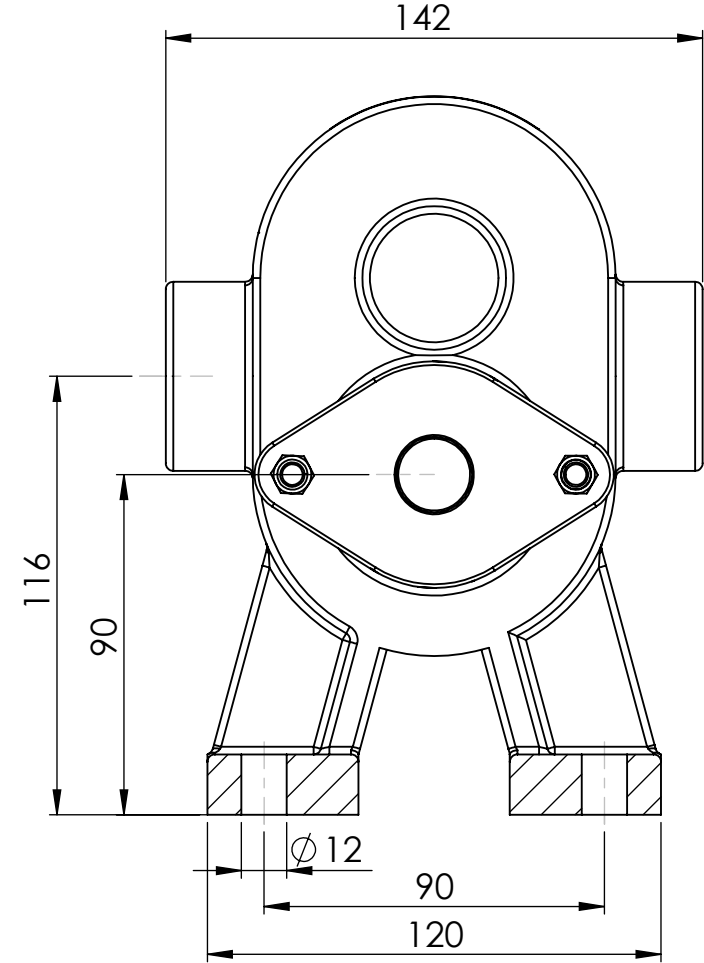
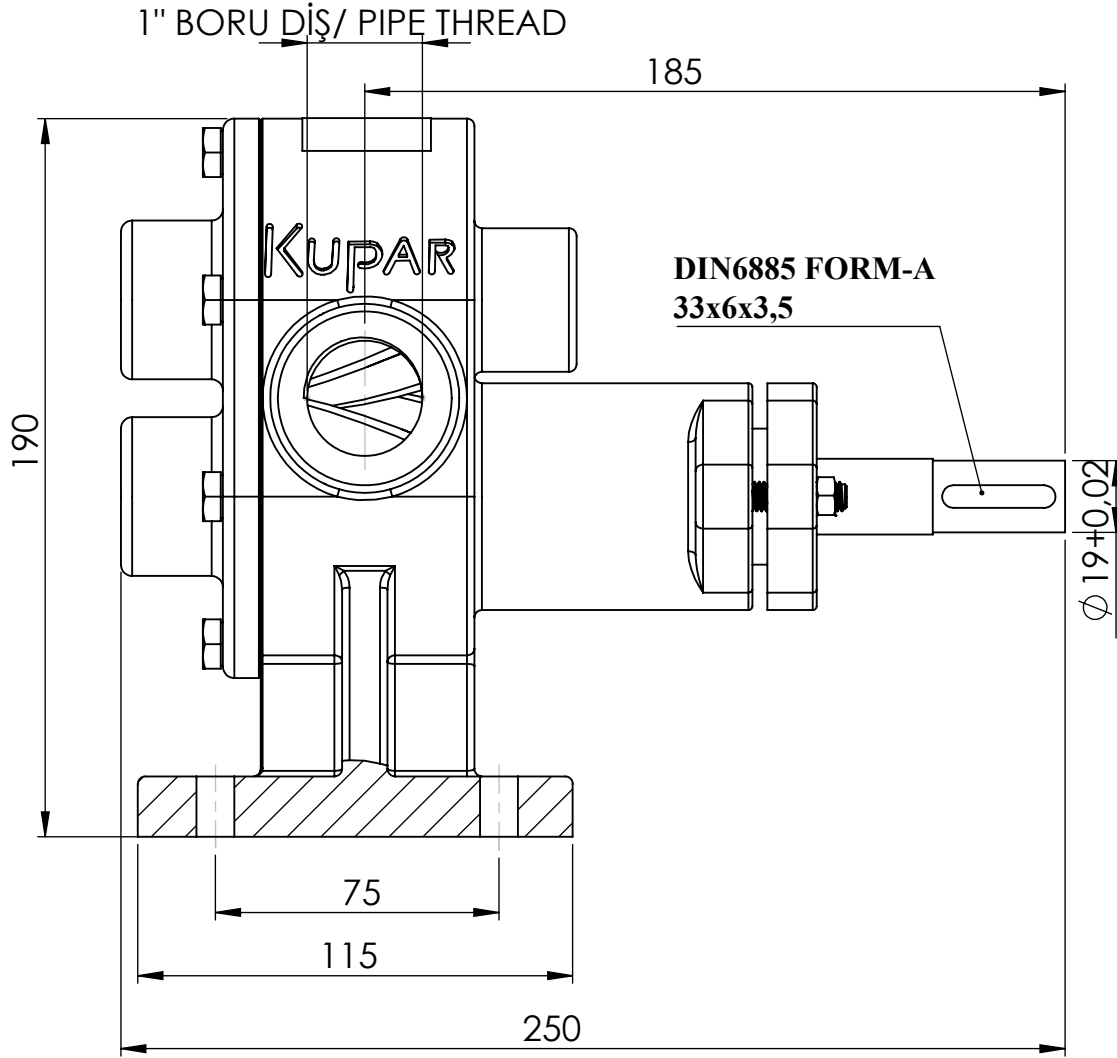

	İSİM / NAME	NOTLAR / NOTES	PARÇA ADI / PART NAME:
ÇİZEN / DRAWN	VEDAT KARTAL		<b>KHP1"</b> <b>HELİS DİŞLİ POMPA</b> <b>HELICAL GEAR PUMP</b>
DENETLEYEN / CONTROLLED	HARUN POLAT		
ONAY / APPROVED	BAŞAR KÜÇÜKPARMAK		
REVİZYON TARİHİ / DATE OF REVISION	11.04.2022		



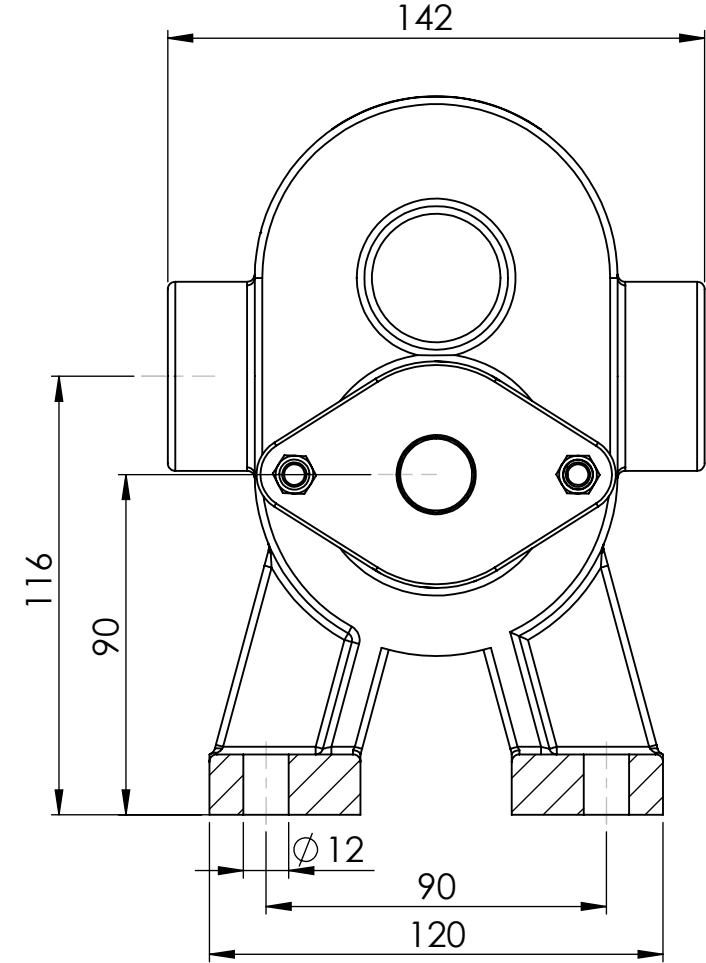
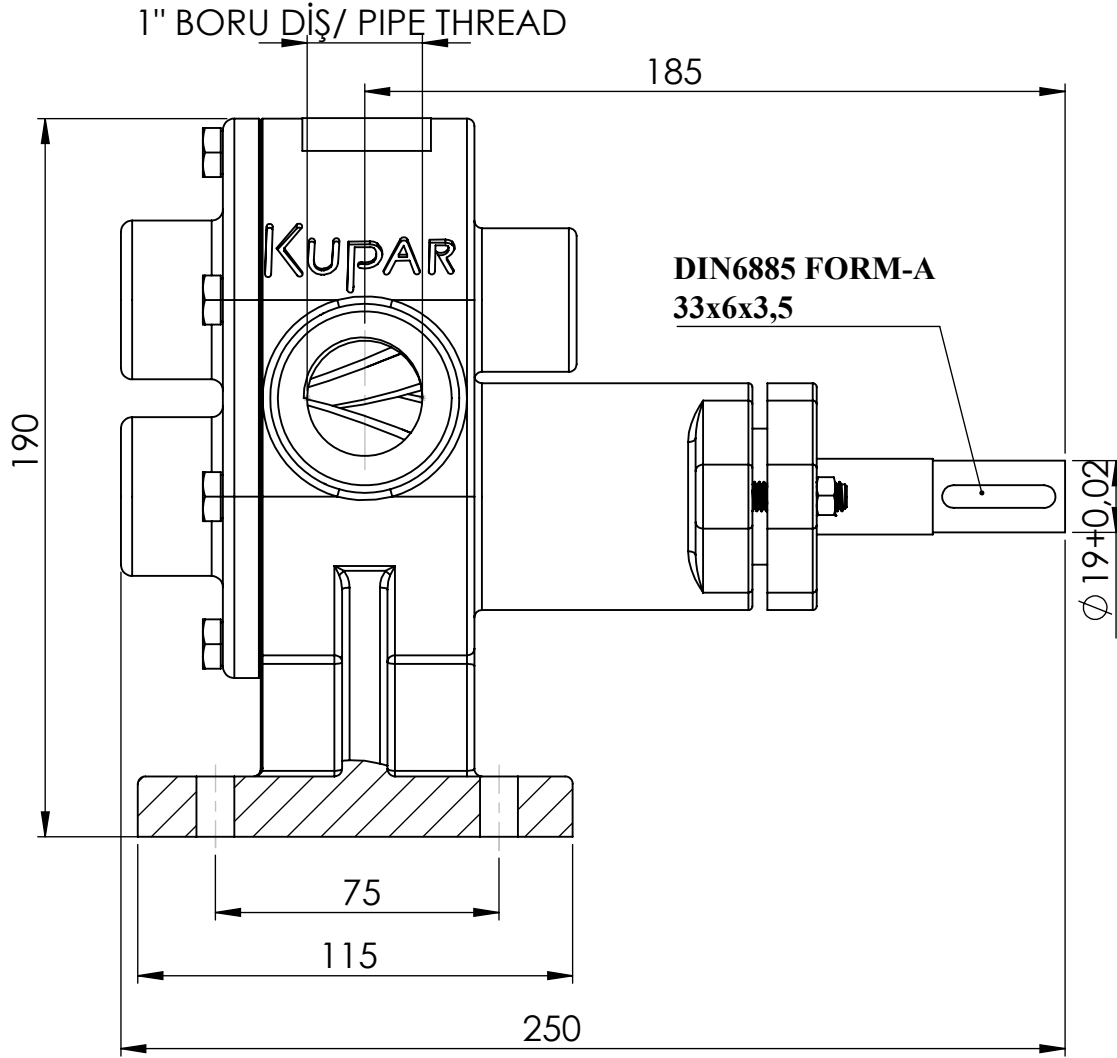

	İSİM / NAME	NOTLAR / NOTES	PARÇA ADI / PART NAME:
ÇİZEN / DRAWN	VEDAT KARTAL		<b>KHP1"</b> <b>HELİS DİŞLİ POMPA</b> <b>HELICAL GEAR PUMP</b>
DENETLEYEN / CONTROLLED	HARUN POLAT		
ONAY / APPROVED	BAŞAR KÜÇÜKPARMAK		
REVİZYON TARİHİ / DATE OF REVISION	11.04.2022		



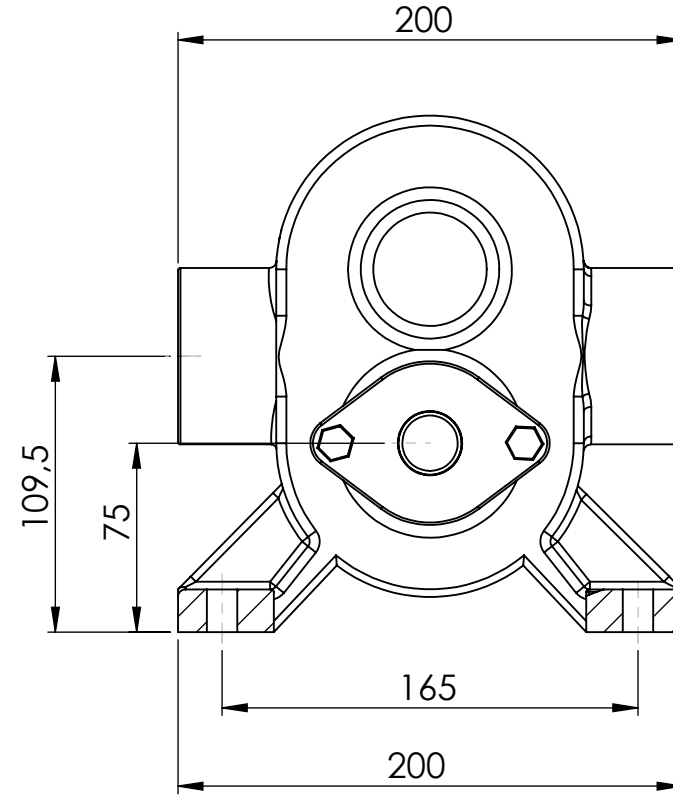
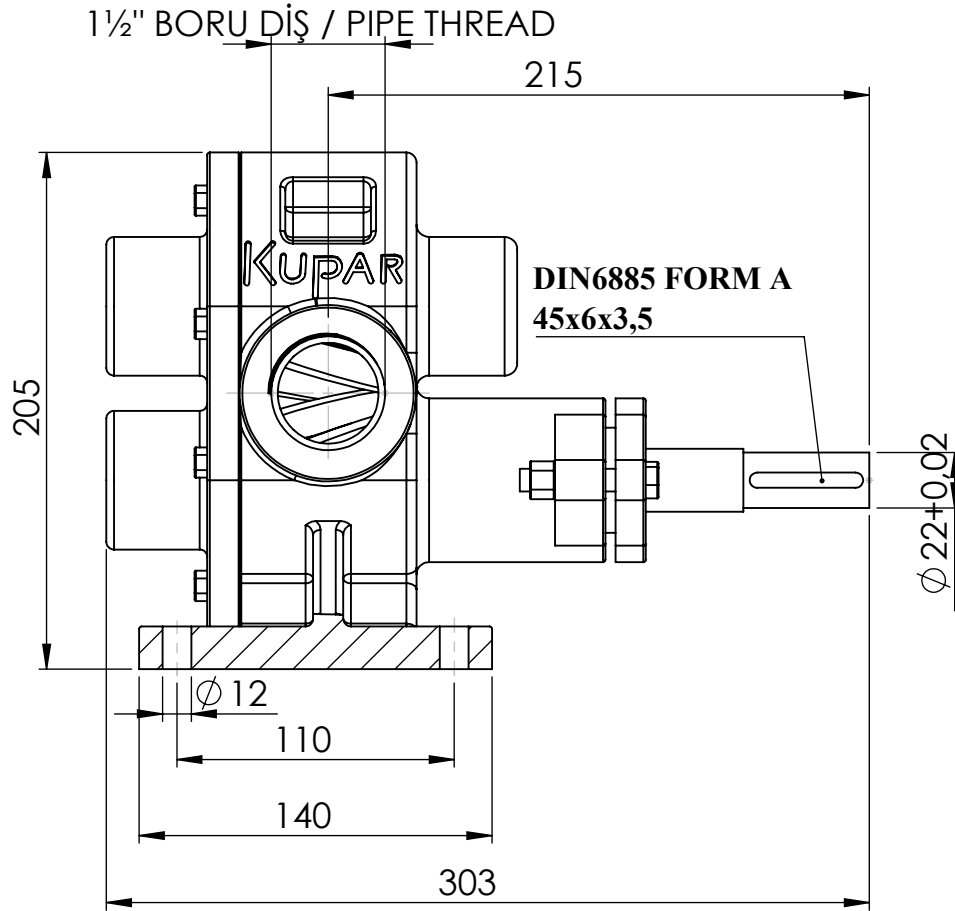

	İSİM / NAME	NOTLAR / NOTES	PARÇA ADI / PART NAME:
ÇİZEN / DRAWN	VEDAT KARTAL		<b>KHP1 1/2"</b> <b>HELİS DİŞLİ POMPA</b> <b>HELICAL GEAR PUMP</b>
DENETLEYEN / CONTROLLED	HARUN POLAT		
ONAY / APPROVED	BAŞAR KÜÇÜKPARMAK		
REVİZYON TARİHİ / DATE OF REVISION	11.01.2022		





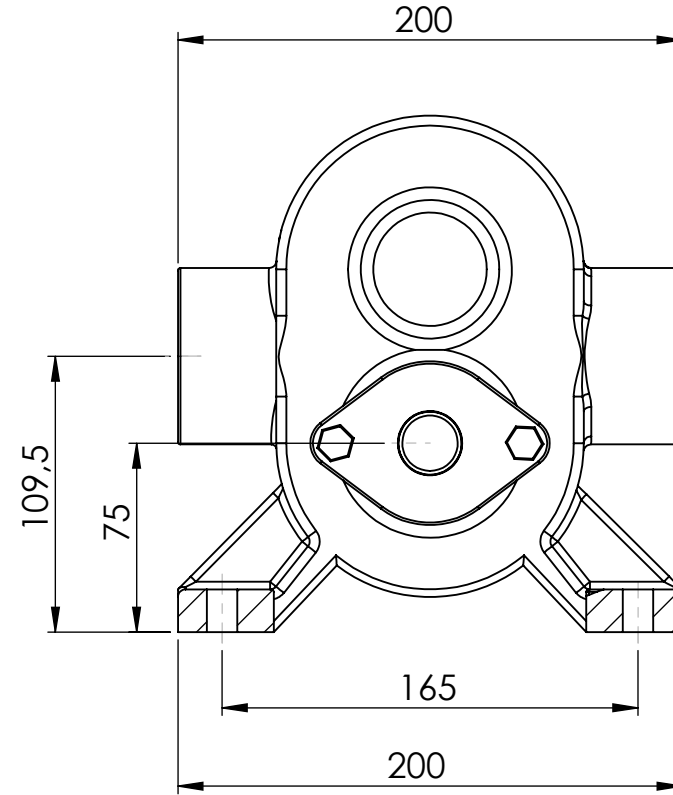
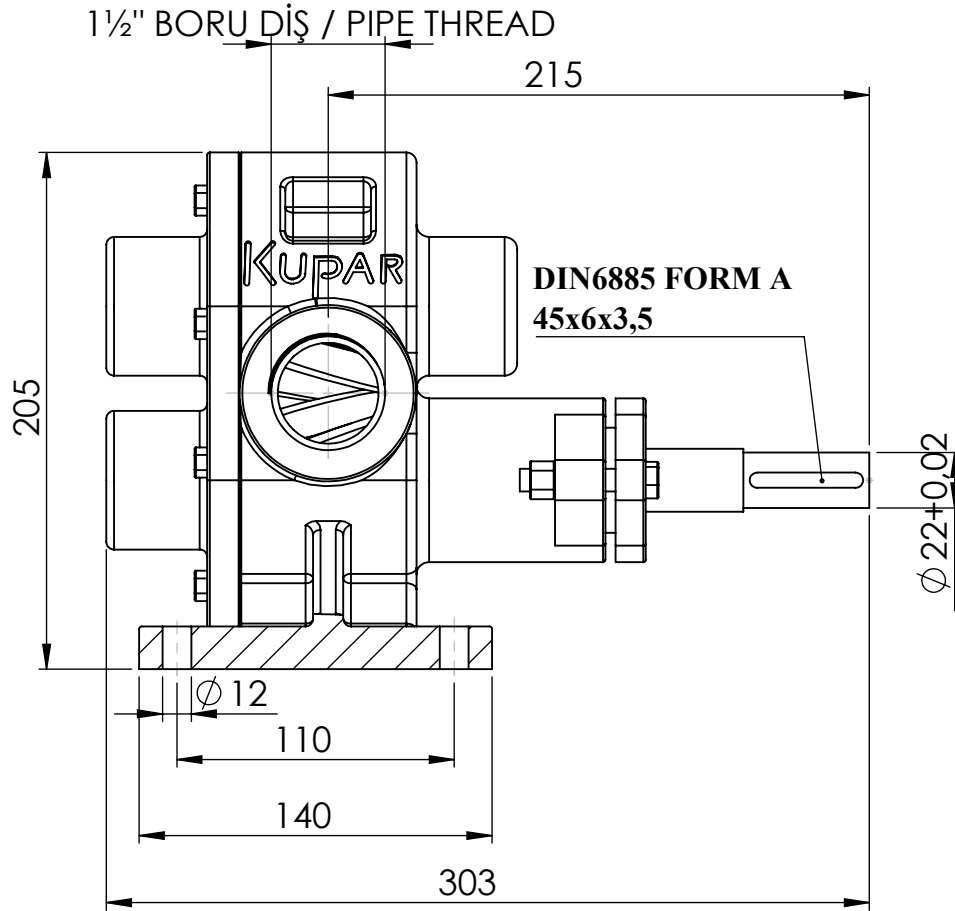

	İSİM / NAME	NOTLAR / NOTES	PARÇA ADI / PART NAME:
ÇİZEN / DRAWN	VEDAT KARTAL		<b>KHP1 1/2"</b> <b>HELİS DİŞLİ POMPA</b> <b>HELICAL GEAR PUMP</b>
DENETLEYEN / CONTROLLED	HARUN POLAT		
ONAY / APPROVED	BAŞAR KÜÇÜKPARMAK		
REVİZYON TARİHİ / DATE OF REVISION	11.01.2022		



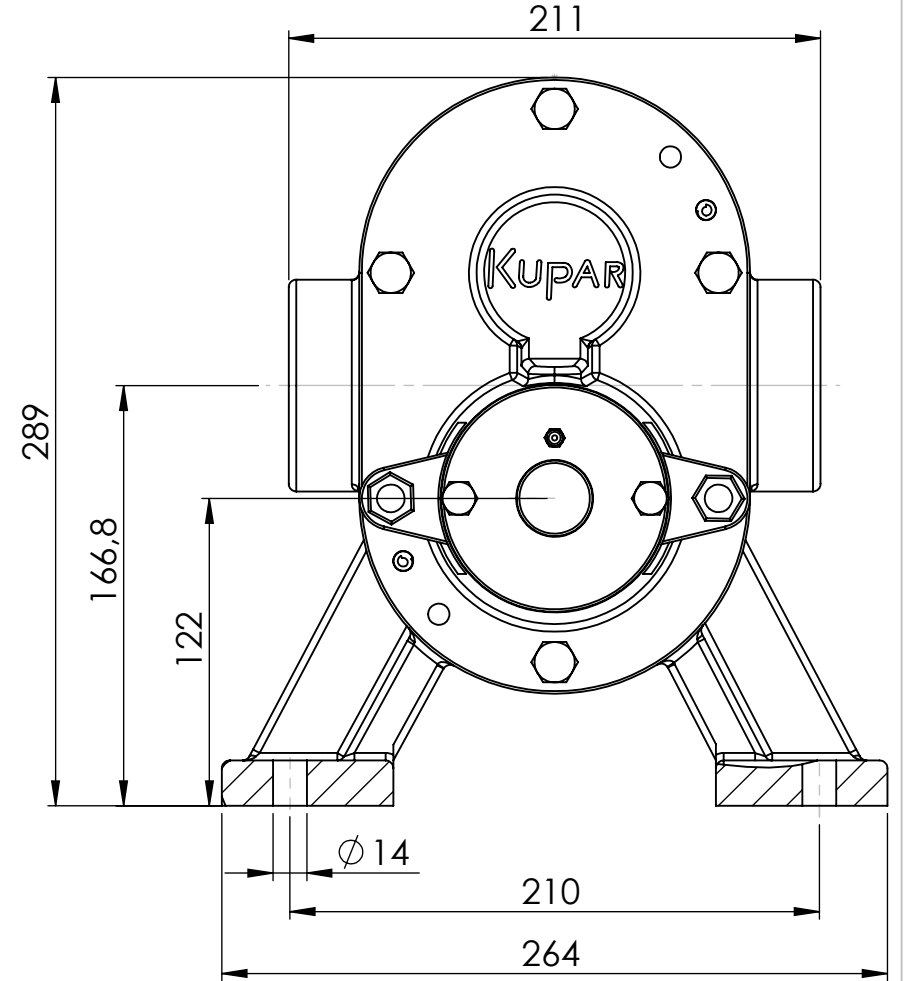
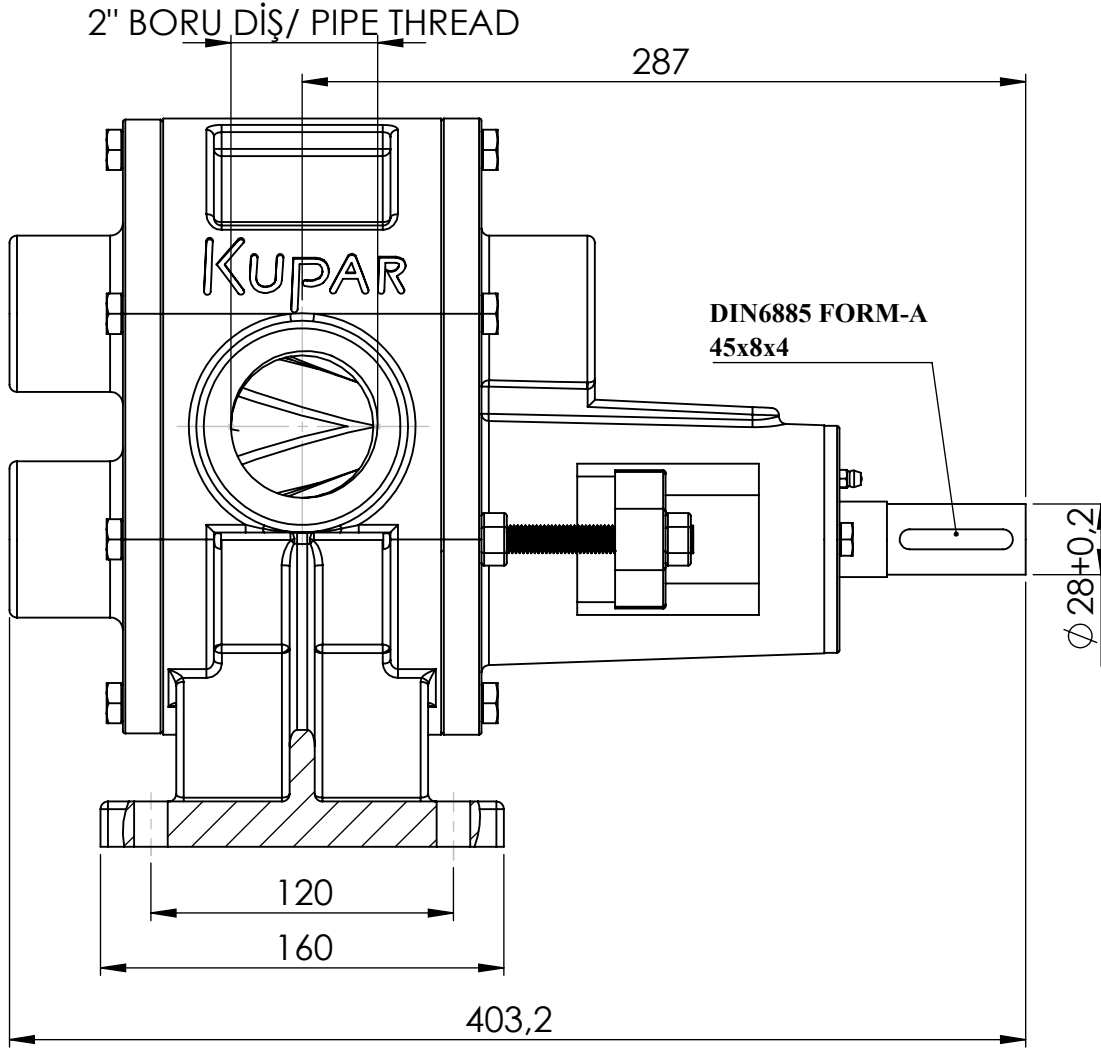

	İSİM / NAME	NOTLAR / NOTES	PARÇA ADI / PART NAME:
ÇİZEN / DRAWN	VEDAT KARTAL		<b>KHP2"</b> <b>HELİS DİŞLİ POMPA</b> <b>HELICAL GEAR PUMP</b>
DENETLEYEN / CONTROLLED	HARUN POLAT		
ONAY / APPROVED	BAŞAR KÜÇÜKPARMAK		
REVİZYON TARİHİ / DATE OF REVISION	04.04.2022		



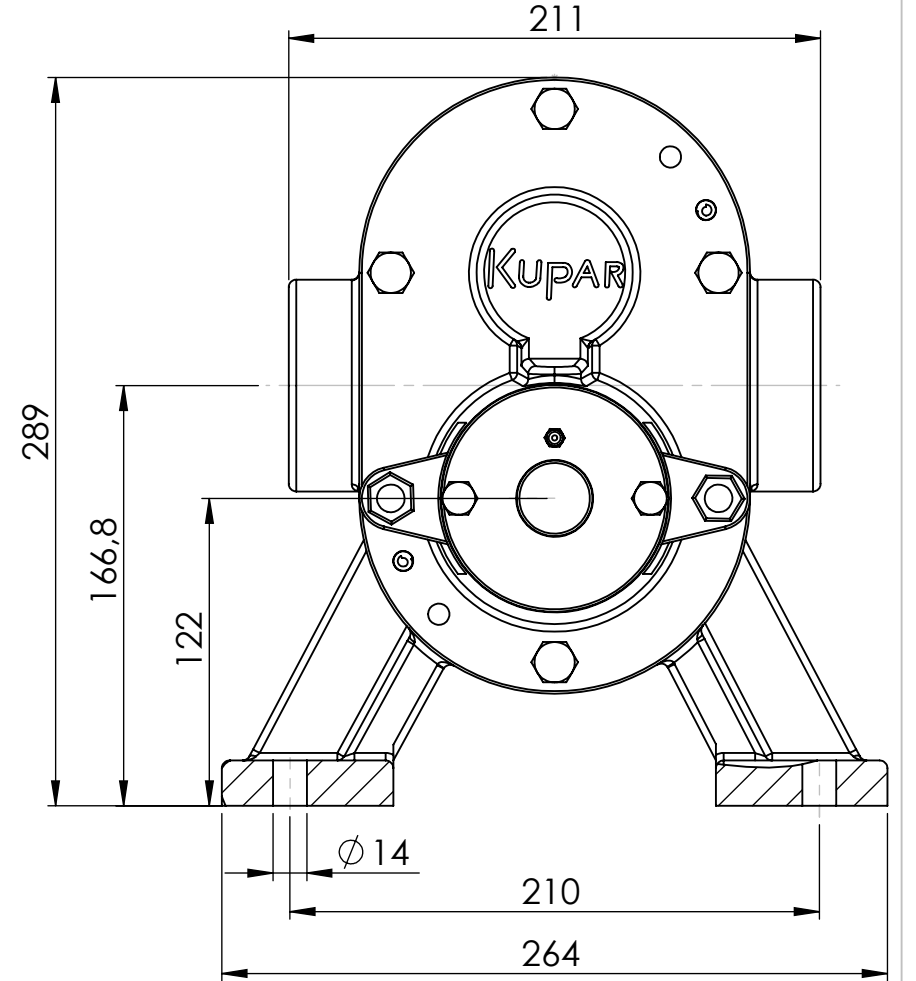
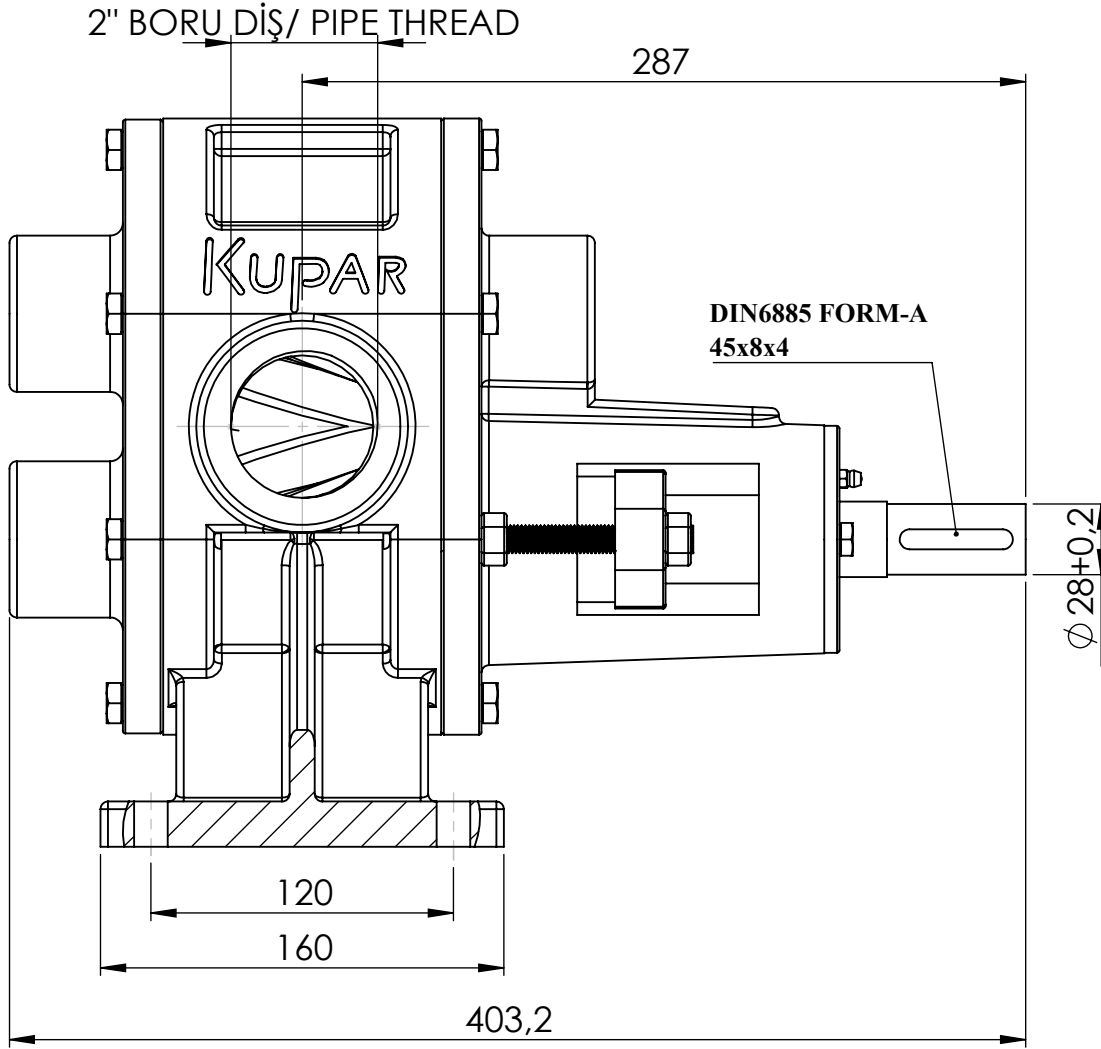

	İSİM / NAME	NOTLAR / NOTES	PARÇA ADI / PART NAME:
ÇİZEN / DRAWN	VEDAT KARTAL		<b>KHP2"</b> <b>HELİS DİŞLİ POMPA</b> <b>HELICAL GEAR PUMP</b>
DENETLEYEN / CONTROLLED	HARUN POLAT		
ONAY / APPROVED	BAŞAR KÜÇÜKPARMAK		
REVİZYON TARİHİ / DATE OF REVISION	04.04.2022		



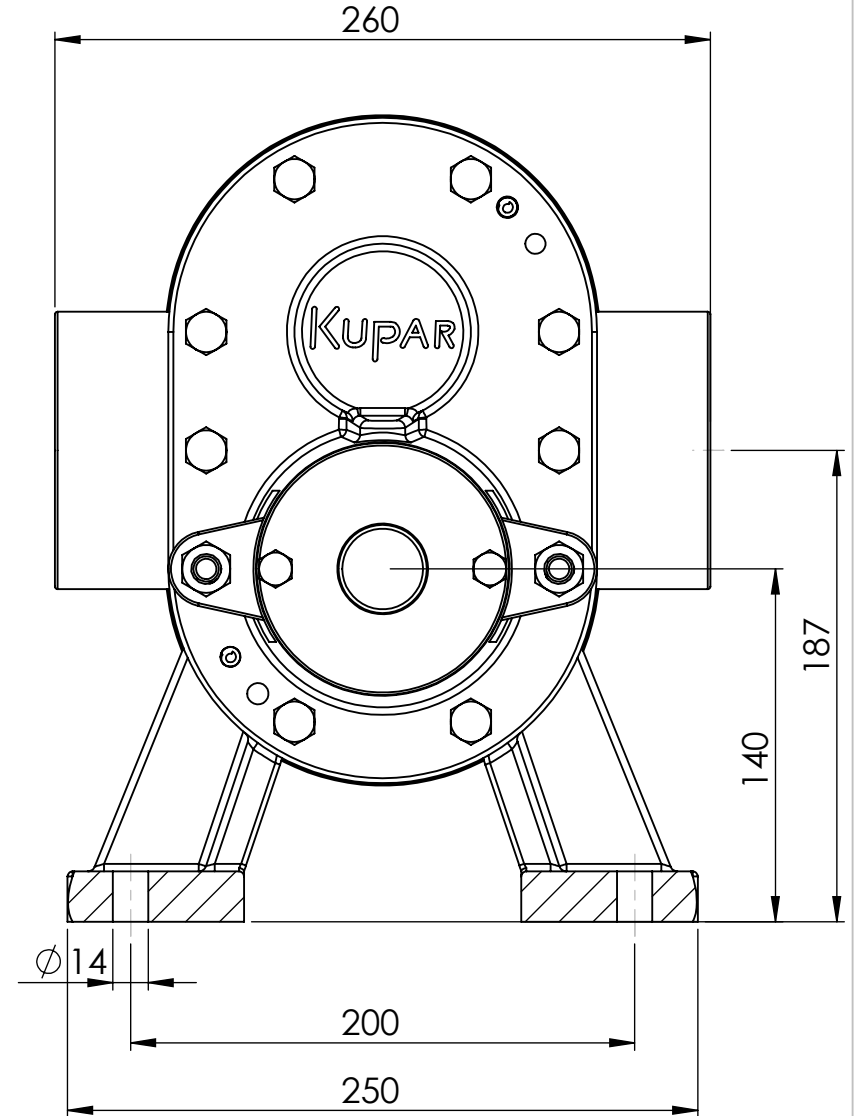
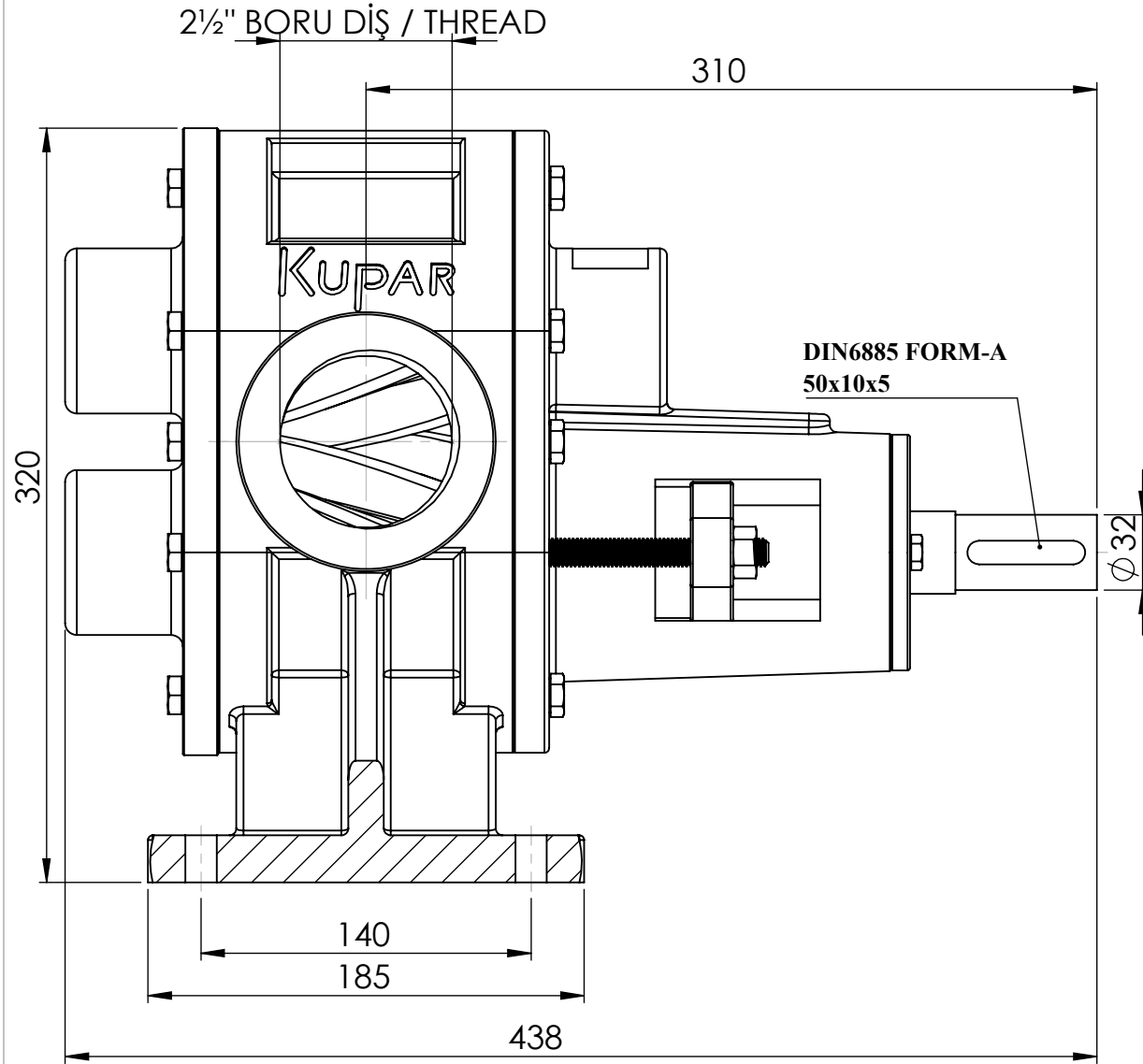

	İSİM / NAME	NOTLAR / NOTES	PARÇA ADI / PART NAME:
ÇİZEN / DRAWN	VEDAT KARTAL		<b>KHP2 1/2"</b> <b>HELİS DİŞLİ POMPA</b> <b>HELICAL GEAR PUMP</b>
DENETLEYEN / CONTROLLED	HARUN POLAT		
ONAY / APPROVED	BAŞAR KÜÇÜKPARMAK		
REVİZYON TARİHİ / DATE OF REVISION	04.04.2022		



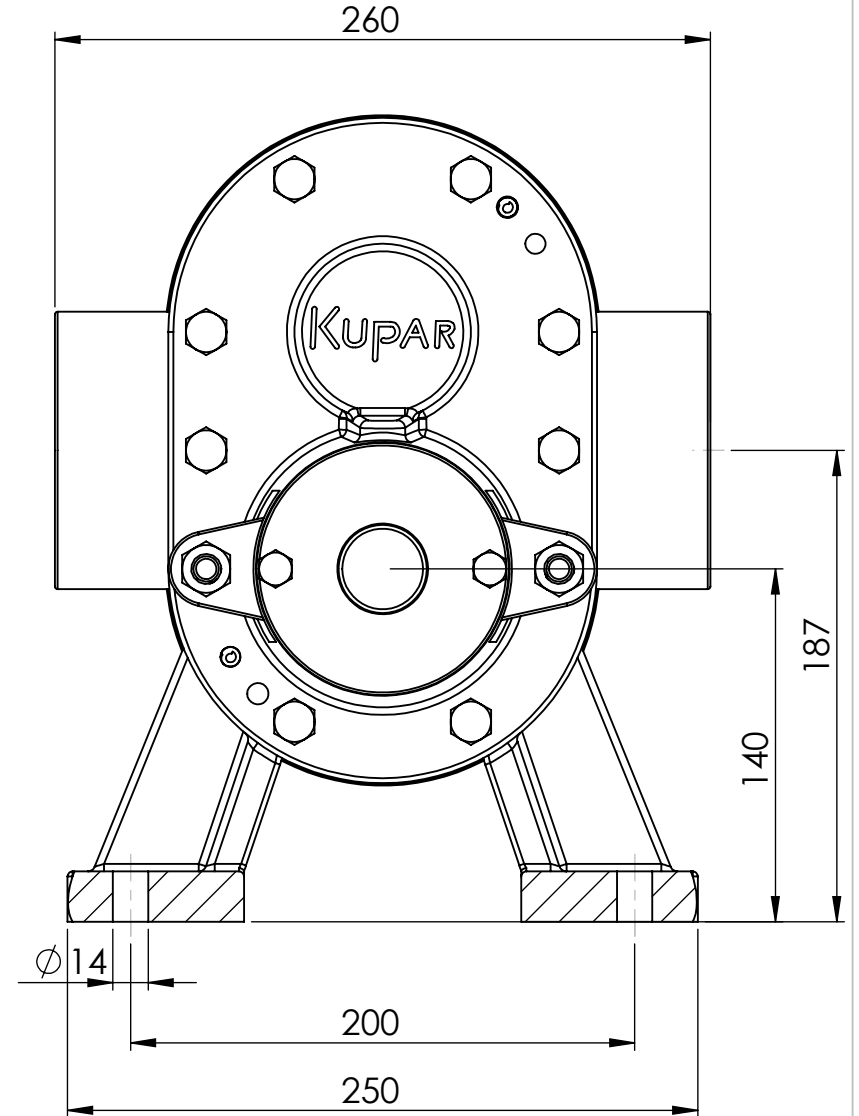
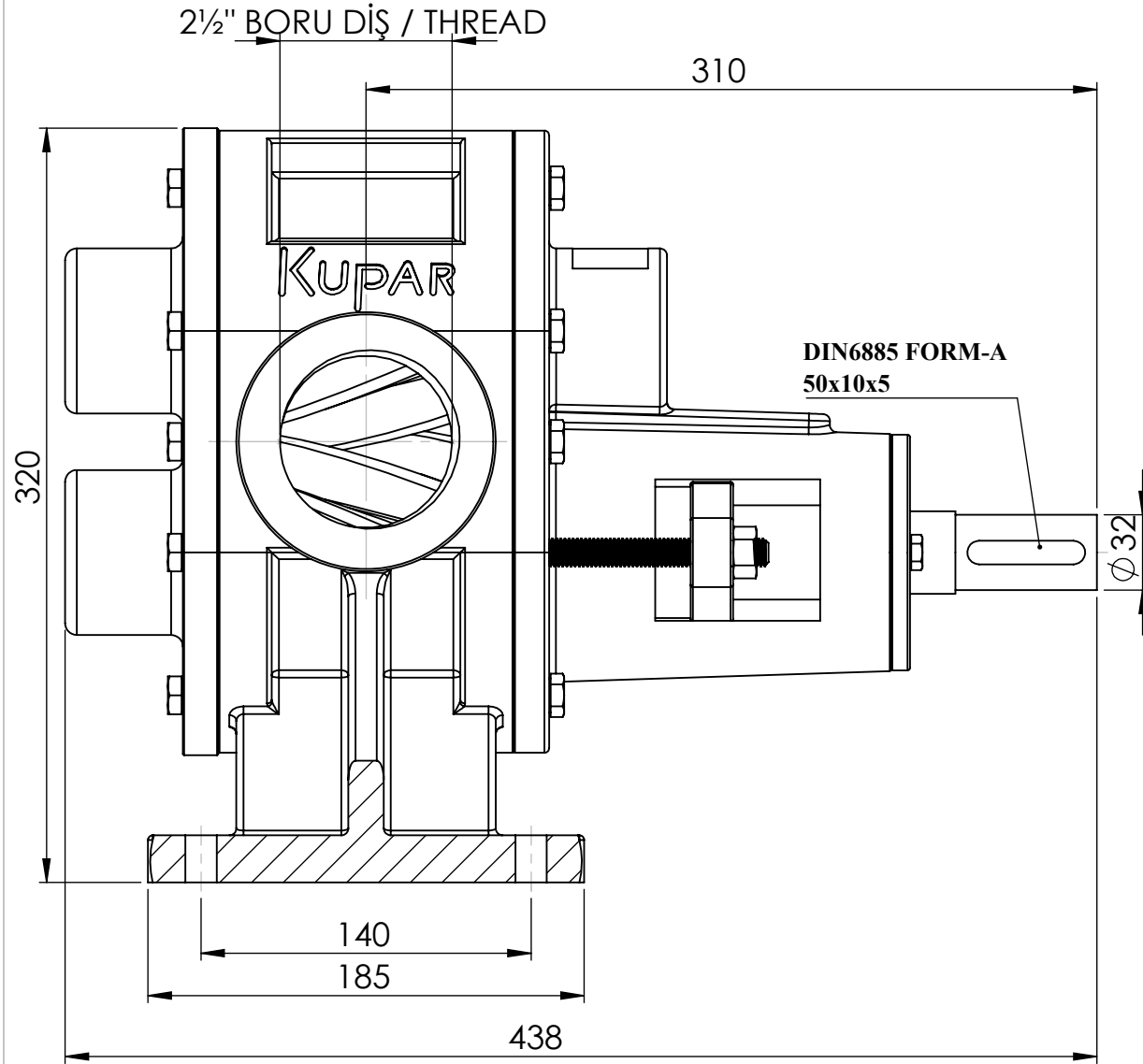

	İSİM / NAME	NOTLAR / NOTES	PARÇA ADI / PART NAME:
ÇİZEN / DRAWN	VEDAT KARTAL		<b>KHP2 1/2"</b> <b>HELİS DİŞLİ POMPA</b> <b>HELICAL GEAR PUMP</b>
DENETLEYEN / CONTROLLED	HARUN POLAT		
ONAY / APPROVED	BAŞAR KÜÇÜKPARMAK		
REVİZYON TARİHİ / DATE OF REVISION	04.04.2022		



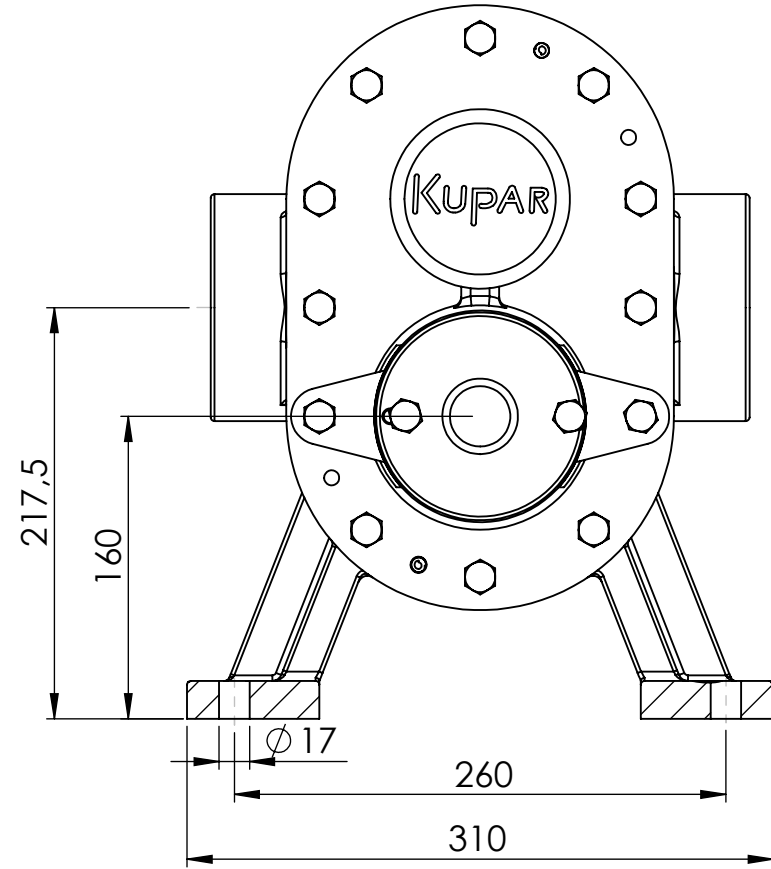
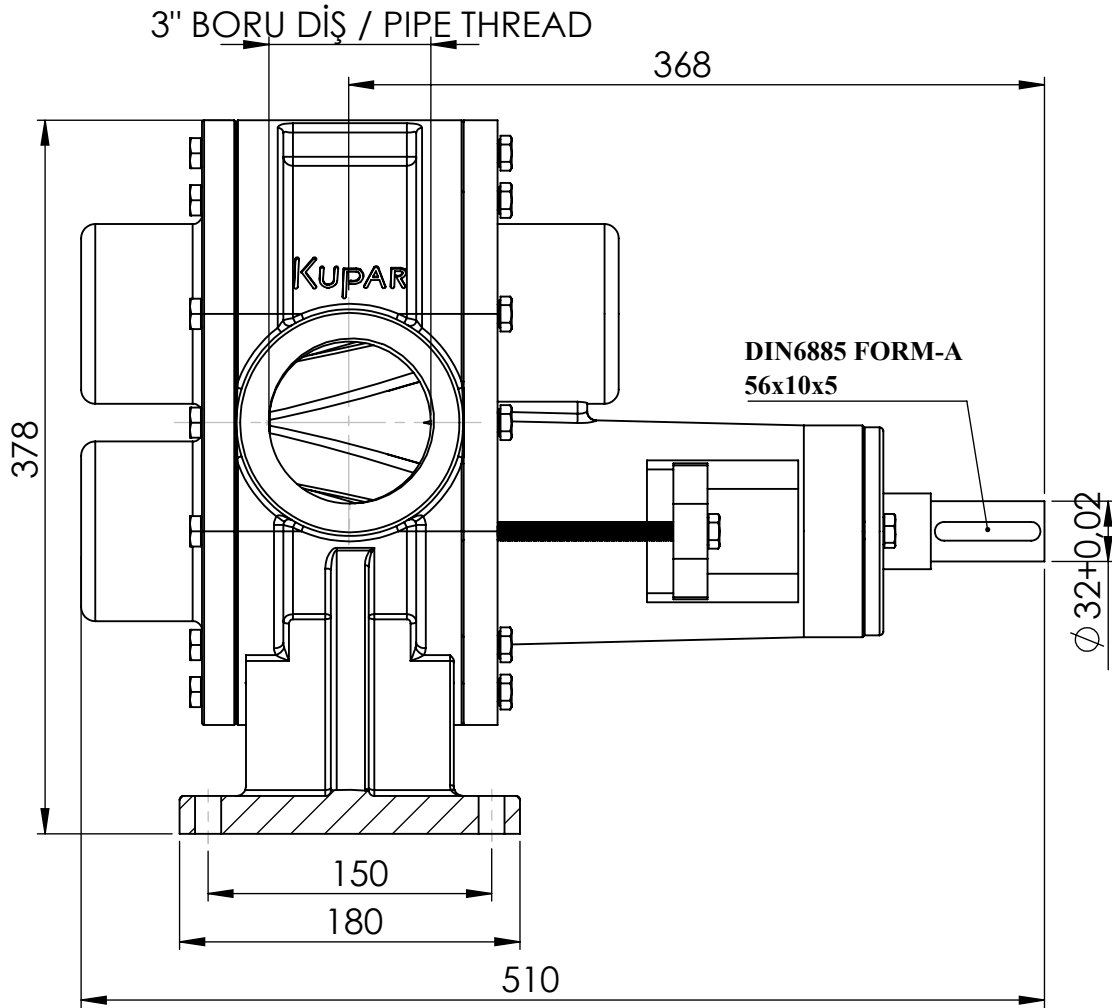

	İSİM / NAME	NOTLAR / NOTES	PARÇA ADI / PART NAME:
ÇİZEN / DRAWN	VEDAT KARTAL		<b>KHP3"</b> <b>HELİS DİŞLİ POMPA</b> <b>HELICAL GEAR PUMP</b>
DENETLEYEN / CONTROLLED	HARUN POLAT		
ONAY / APPROVED	BAŞAR KÜÇÜKPARMAK		
REVİZYON TARİHİ / DATE OF REVISION	11.04.2022		

